

INDEX	OL-36083
REV. LEVEL	0
SHEET	1 OF 1

TOSHIBA/HOUSTON

**TOTALLY-ENCLOSED FAN-COOLED
HORIZONTAL FOOT-MOUNTED
QUARRY-DUTY (CI T-BOX)**

Fr. 364T-365T

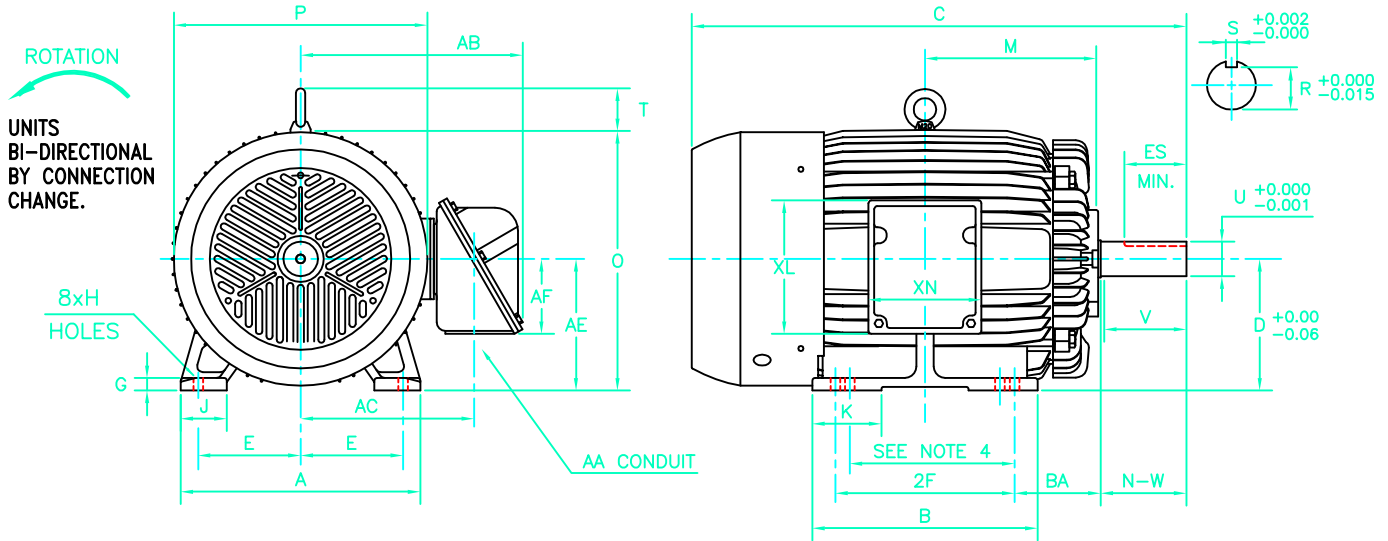

UNITS: INCHES

FRAME SIZE	MOUNTING				CONDUIT BOX							
	E	2F	H	BA	AA	AB	AC	AE	AF	XL	XN	
364T	7.00	11.25	0.66	5.88	3.00	15.2	11.9	9.0	5.1	9.1	7.7	
365T	7.00	12.25	0.66	5.88	3.00	15.2	11.9	9.0	5.1	9.1	7.7	

FRAME SIZE	MOTOR DIMENSIONS										
	A	B	C	D	G	J	K	M	O	P	T
364T/365T	16.4	15.4	33.8	9.00	0.9	3.2	4.7	11.8	17.7	17.3	2.9

FRAME SIZE	SHAFT EXTENSION			KEY SEAT			BEARINGS		MAXIMUM WEIGHT
	N-W	V	U	R	S	ES	LS	OS	
364T/365T	5.88	5.62	2.375	2.021	0.625	4.28	6314C3	6312C3	861 lbs.

NOTES:

- DIMENSION V REPRESENTS LENGTH OF STRAIGHT PART OF SHAFT.
- CONDUIT BOX MAY BE ROTATED IN 90° INCREMENTS AND MAY BE MOUNTED ON OPPOSITE SIDE ON SPECIAL ORDER.
- "T" KEY DIMENSIONS EQUAL S x S x 4.25 "TS" KEY DIMENSIONS EQUAL S x S x 2.00 (MOTOR SUPPLIED WITH KEY)
- DIMENSIONS FOR 364T MOUNTING EQUAL (2F) LOCATED IN 364T SIDE VIEW.
- MOTOR WEIGHT SHOWN IS MAXIMUM HORSEPOWER IN FRAME.

ALL DATA SUBJECT TO CHANGE WITHOUT NOTICE.
FOR CONSTRUCTION USE ONLY CERTIFIED DATA.

CERTIFIED DATA

CUSTOMER: _____ P.O. NO.: _____ TAG NO.: _____
 MOTOR MODEL NO.: _____ TOSHIBA FILE NO.: _____
 HP: _____ RPM (SYN.): _____ VOLTAGE: _____ Hz: _____
 FRAME SIZE: _____ LOG NO.: _____ LOG REV. LEVEL: _____
 REMARKS: _____

 PER: _____ ISSUE DATE: _____ SUPERSEDES: _____