

INDEX	MDSL0042-14
REV. LEVEL	0
SHEET	1 OF 1

TOSHIBA/HOUSTON

**EXPLOSION PROOF
HORIZONTAL FOOT-MOUNTED
F-2 ASSEMBLY**

**HAZARDOUS LOCATION
CLASS I GROUP D
CLASS II GROUP E, F, AND G**

**Fr. 447TZ
BELT DRIVE**

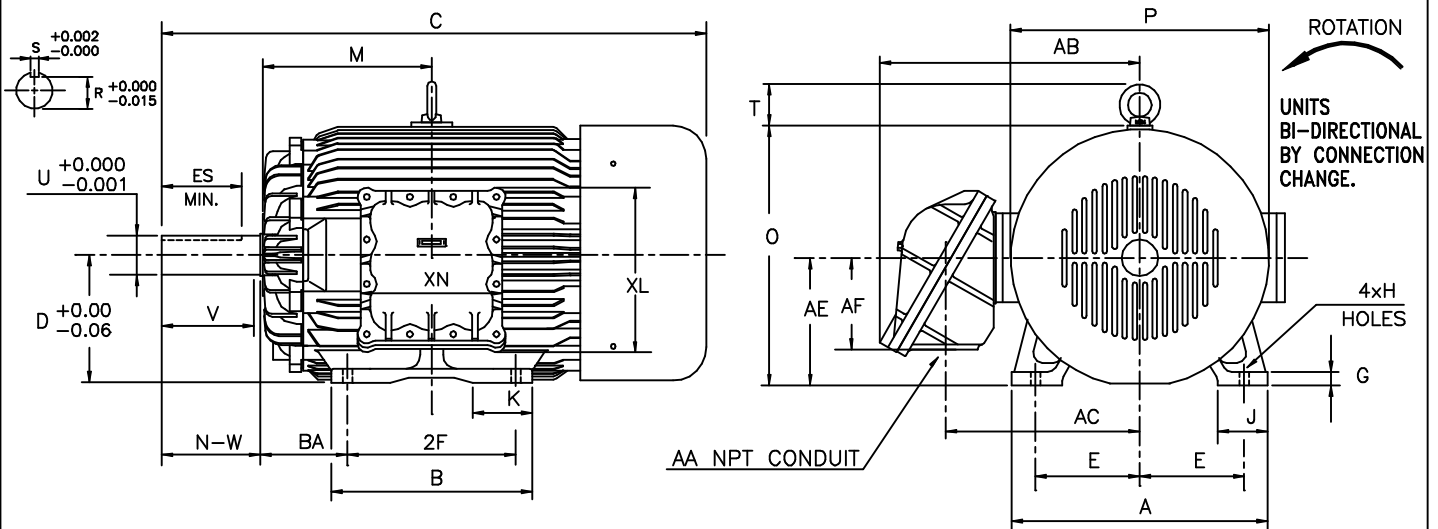

UNITS: INCHES

FRAME SIZE	MOUNTING				CONDUIT BOX						
	E	2F	H	BA	AA	AB	AC	AE	AF	XL	XN
447TZ	9.00	20.00	0.81	7.50	3.00	22.4	16.7	11.0	7.9	14.7	12.2

FRAME SIZE	MOTOR DIMENSIONS										
	A	B	C	D	G	J	K	M	O	P	T
447TZ	22.1	22.8	54.1	11.00	1.2	4.3	4.7	17.3	22.4	22.2	3.5

FRAME SIZE	SHAFT EXTENSION			KEY SEAT			BEARINGS		MAXIMUM WEIGHT
	N-W	V	U	R	S	ES	LS	OS	
447TZ	10.13	9.88	3.375	2.88	0.875	8.53	NU318C3	6313C3	2404 lbs.

NOTES:

1. DIMENSION V REPRESENTS LENGTH OF STRAIGHT PART OF SHAFT
2. CONDUIT BOX MAY BE ROTATED IN 90° INCREMENTS AND MAY BE MOUNTED ON OPPOSITE SIDE ON SPECIAL ORDERS
3. KEY DIMENSIONS EQUAL S x S x 8.50 (MOTOR SUPPLIED WITH KEY)
4. MOTOR WEIGHT SHOWN IS MAXIMUM HORSEPOWER IN FRAME.

ALL DATA SUBJECT TO CHANGE WITHOUT NOTICE.
FOR CONSTRUCTION USE ONLY CERTIFIED DATA.

CERTIFIED DATA

CUSTOMER: _____ P.O. NO.: _____ TAG NO.: _____

MOTOR MODEL NO.: _____ TOSHIBA FILE NO.: _____

HP: _____ RPM (SYN.): _____ VOLTAGE: _____ Hz: _____

FRAME SIZE: _____ LOG NO.: _____ LOG REV. LEVEL: _____

REMARKS: _____

PER: _____ ISSUE DATE: _____ SUPERSEDES: _____