

INDEX	MDSL0042-11
REV. LEVEL	1
SHEET	1 OF 1

TOSHIBA/HOUSTON

**EXPLOSION PROOF
HORIZONTAL FOOT-MOUNTED
F-2 ASSEMBLY**

**HAZARDOUS LOCATION
CLASS I GROUP D
CLASS II GROUP E, F, AND G**

**Fr. 444T-445T
BELT DRIVE**

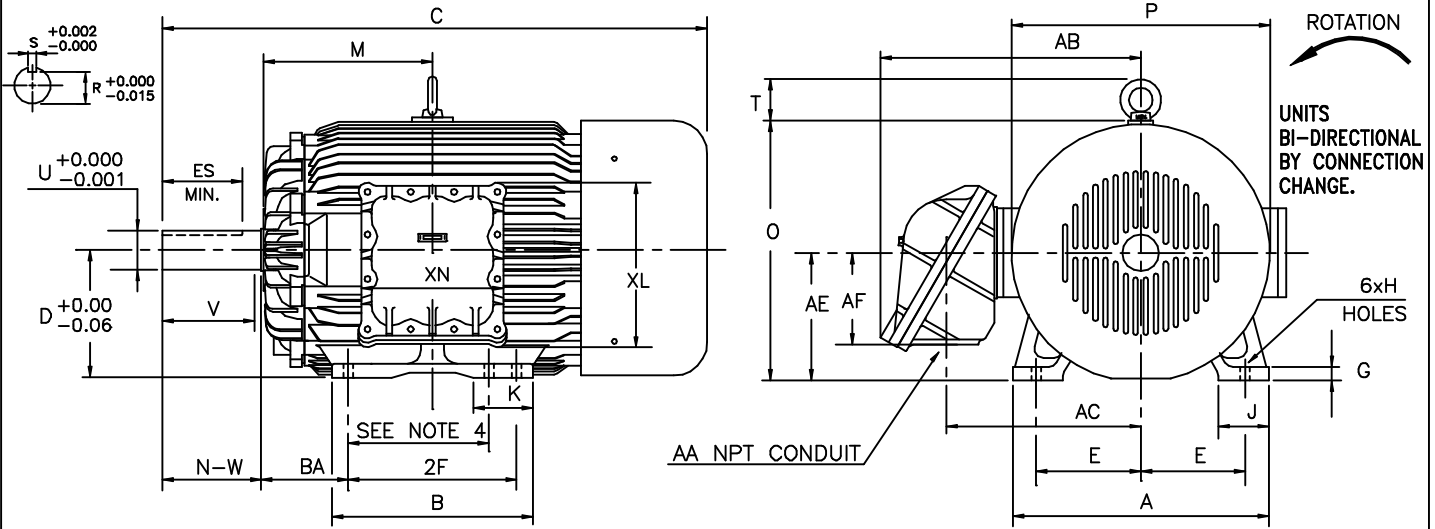

UNITS: INCHES

FRAME SIZE	MOUNTING				CONDUIT BOX						
	E	2F	H	BA	AA	AB	AC	AE	AF	XL	XN
444T	9.00	14.50	0.81	7.50	3.00	22.4	16.7	11.0	7.9	14.7	12.2
445T	9.00	16.50	0.81	7.50	3.00	22.4	16.7	11.0	7.9	14.7	12.2

FRAME SIZE	MOTOR DIMENSIONS										
	A	B	C	D	G	J	K	M	O	P	T
444T/445T	22.1	19.3	48.9	11.00	1.2	4.3	5.1	15.5	22.4	22.2	3.5

FRAME SIZE	SHAFT EXTENSION			KEY SEAT			BEARINGS		MAXIMUM WEIGHT
	N-W	V	U	R	S	ES	LS	OS	
444T/445T	8.50	8.25	3.375	2.88	0.875	6.91	NU318C3	6313C3	2123 lbs.

NOTES:

1. DIMENSION V REPRESENTS LENGTH OF STRAIGHT PART OF SHAFT
2. CONDUIT BOX MAY BE ROTATED IN 90° INCREMENTS AND MAY BE MOUNTED ON OPPOSITE SIDE ON SPECIAL ORDERS
3. KEY DIMENSIONS EQUAL S x S x 6.88 (MOTOR SUPPLIED WITH KEY)
4. DIMENSIONS (2F) FOR 444T MOUNTING EQUAL (2F) LOCATED IN 444T SIDE VIEW.
5. MOTOR WEIGHT SHOWN IS MAXIMUM HORSEPOWER IN FRAME.

ALL DATA SUBJECT TO CHANGE WITHOUT NOTICE.
FOR CONSTRUCTION USE ONLY CERTIFIED DATA.

CERTIFIED DATA

CUSTOMER: _____ P.O. NO.: _____ TAG NO.: _____

MOTOR MODEL NO.: _____ TOSHIBA FILE NO.: _____

HP: _____ RPM (SYN.): _____ VOLTAGE: _____ Hz: _____

FRAME SIZE: _____ LOG NO.: _____ LOG REV. LEVEL: _____

REMARKS: _____

PER: _____ ISSUE DATE: _____ SUPERSEDES: _____