

INDEX	MDSL0041-07
REV. LEVEL	3
SHEET	1 OF 1

TOSHIBA/HOUSTON EXPLOSION PROOF
HORIZONTAL FOOT-MOUNTED

HAZARDOUS LOCATION
CLASS I GROUP D
CLASS II GROUP E, F, AND G

Fr. 364T-365T
Fr. 364TS-365TS

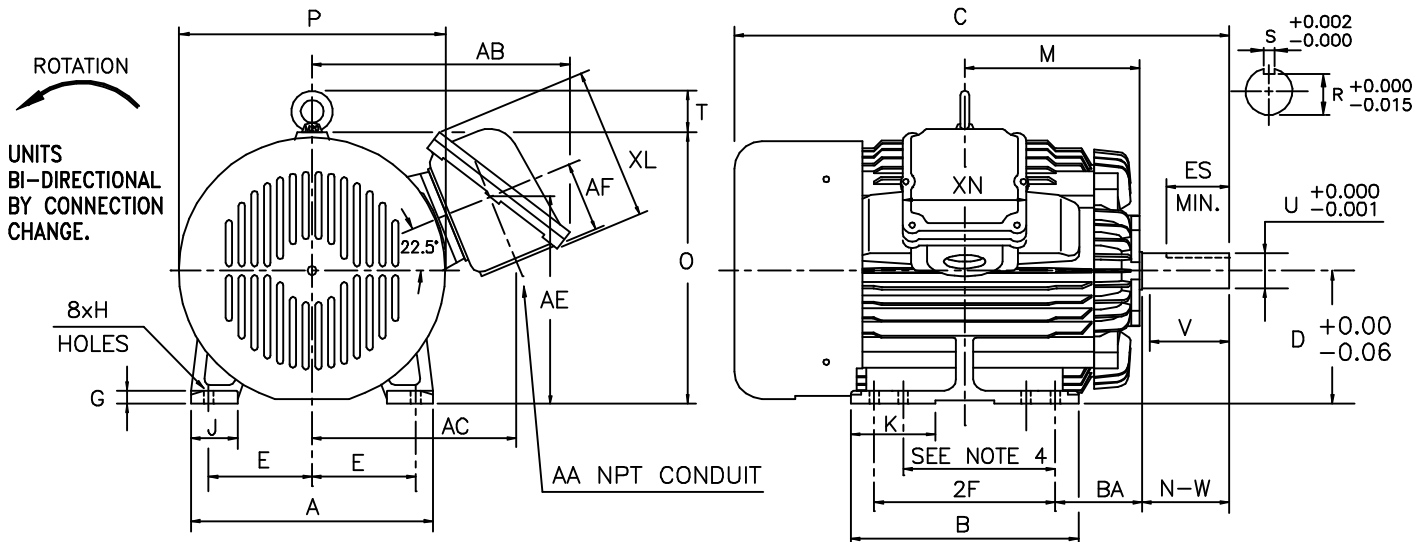

UNITS: INCHES

FRAME SIZE	MOUNTING				CONDUIT BOX						
	E	2F	H	BA	AA	AB	AC	AE	AF	XL	XN
364T/TS	7.00	11.25	0.66	5.88	3.00	17.4	13.8	14.0	4.7	10.3	8.4
365T/TS	7.00	12.25	0.66	5.88	3.00	17.4	13.8	14.0	4.7	10.3	8.4

FRAME SIZE	MOTOR DIMENSIONS										
	A	B	C	D	G	J	K	M	O	P	T
364T/365T	16.4	15.4	33.5	9.00	0.9	3.2	4.7	11.8	18.4	18.0	2.8
364TS/365TS	16.4	15.4	31.3	9.00	0.9	3.2	4.7	11.8	18.4	18.0	2.8

FRAME SIZE	SHAFT EXTENSION			KEY SEAT			BEARINGS		MAXIMUM WEIGHT
	N-W	V	U	R	S	ES	LS	OS	
364T/365T	5.88	5.63	2.375	2.021	0.625	4.28	6314C3	6312C3	1001 lbs.
364TS/365TS	3.75	3.50	1.875	1.591	0.500	2.03	6312C3	6312C3	984 lbs.

NOTES:

- DIMENSION V REPRESENTS LENGTH OF STRAIGHT PART OF SHAFT
- CONDUIT BOX MAY BE ROTATED IN 90° INCREMENTS AND MAY BE MOUNTED ON OPPOSITE SIDE ON SPECIAL ORDERS
- "T" KEY DIMENSIONS EQUAL S x S x 4.25
"TS" KEY DIMENSIONS EQUAL S x S x 2.00 (MOTOR SUPPLIED WITH KEY)
- DIMENSIONS FOR 364T MOUNTING EQUAL (2F) LOCATED IN 364T SIDE VIEW.
- MOTOR WEIGHT SHOWN IS MAXIMUM HORSEPOWER IN FRAME.

ALL DATA SUBJECT TO CHANGE WITHOUT NOTICE.
FOR CONSTRUCTION USE ONLY CERTIFIED DATA.

CERTIFIED DATA

CUSTOMER: _____ P.O. NO.: _____ TAG NO.: _____

MOTOR MODEL NO.: _____ TOSHIBA FILE NO.: _____

HP: _____ RPM (SYN.): _____ VOLTAGE: _____ Hz: _____

FRAME SIZE: _____ LOG NO.: _____ LOG REV. LEVEL: _____

REMARKS: _____

PER: _____ ISSUE DATE: _____ SUPERSEDES: _____