

INDEX	MDSL0041-06
REV. LEVEL	4
SHEET	1 OF 1

TOSHIBA/HOUSTON EXPLOSION PROOF HORIZONTAL FOOT-MOUNTED
 HAZARDOUS LOCATION CLASS I GROUP D CLASS II GROUP E, F, AND G
 Fr. 324T-326T Fr. 324TS-326TS

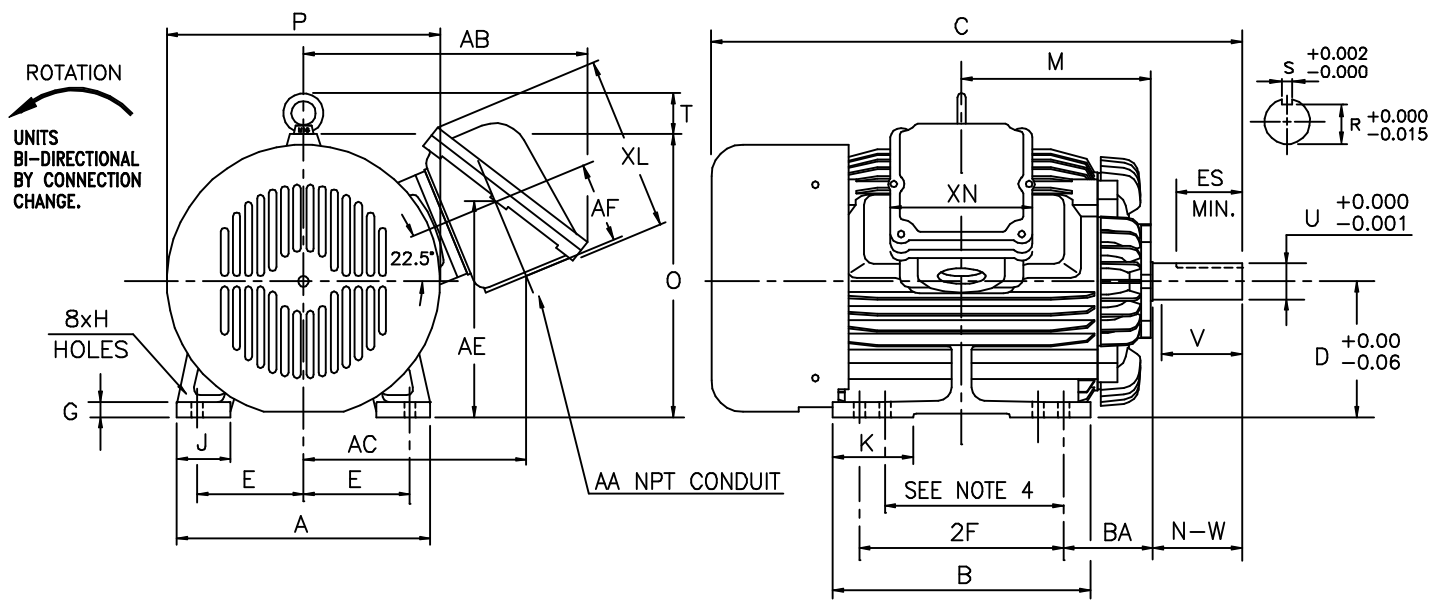

UNITS: INCHES

FRAME SIZE	MOUNTING				CONDUIT BOX						
	E	2F	H	BA	AA	AB	AC	AE	AF	XL	XN
324T/TS	6.25	10.5	0.66	5.25	2.00	16.7	13.1	12.7	4.7	10.3	8.4
326T/TS	6.25	12.0	0.66	5.25	2.00	16.7	13.1	12.7	4.7	10.3	8.4

FRAME SIZE	MOTOR DIMENSIONS										
	A	B	C	D	G	J	K	M	O	P	T
324T/326T	14.9	15.2	31.3	8.00	0.9	3.2	4.7	11.1	16.7	16.1	2.4
324TS/326TS	14.9	15.2	29.7	8.00	0.9	3.2	4.7	11.1	16.7	16.1	2.4

FRAME SIZE	SHAFT EXTENSION			KEY SEAT			BEARINGS		MAXIMUM WEIGHT
	N-W	V	U	R	S	ES	LS	OS	
324T/326T	5.25	5.00	2.125	1.845	0.500	3.91	6312ZZC3	6312ZZC3	650 lbs.
324TS/326TS	3.75	3.50	1.875	1.591	0.500	2.03	6312C3	6310C3	735 lbs.

- NOTES:
- DIMENSION V REPRESENTS LENGTH OF STRAIGHT PART OF SHAFT
 - CONDUIT BOX MAY BE ROTATED IN 90° INCREMENTS AND MAY BE MOUNTED ON OPPOSITE SIDE ON SPECIAL ORDERS
 - "T" KEY DIMENSIONS EQUAL S x S x 3.88
"TS" KEY DIMENSIONS EQUAL S x S x 2.00 (MOTOR SUPPLIED WITH KEY)
 - DIMENSIONS FOR 324T MOUNTING EQUAL (2F) LOCATED IN 324T SIDE VIEW.
 - MOTOR WEIGHT SHOWN IS MAXIMUM HORSEPOWER IN FRAME.

ALL DATA SUBJECT TO CHANGE WITHOUT NOTICE.
 FOR CONSTRUCTION USE ONLY CERTIFIED DATA.

CERTIFIED DATA

CUSTOMER: _____ P.O. NO.: _____ TAG NO.: _____
 MOTOR MODEL NO.: _____ TOSHIBA FILE NO.: _____
 HP: _____ RPM (SYN.): _____ VOLTAGE: _____ Hz: _____
 FRAME SIZE: _____ LOG NO.: _____ LOG REV. LEVEL: _____
 REMARKS: _____
 PER: _____ ISSUE DATE: _____ SUPERSEDES: _____