

|            |             |
|------------|-------------|
| INDEX      | MDSL0063-01 |
| REV. LEVEL | 1           |
| SHEET      | 1 OF 1      |

ROTATION  
UNITS  
BI-DIRECTIONAL  
BY CONNECTION  
CHANGE.

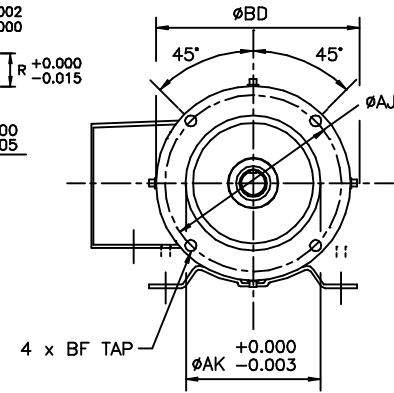
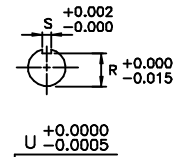
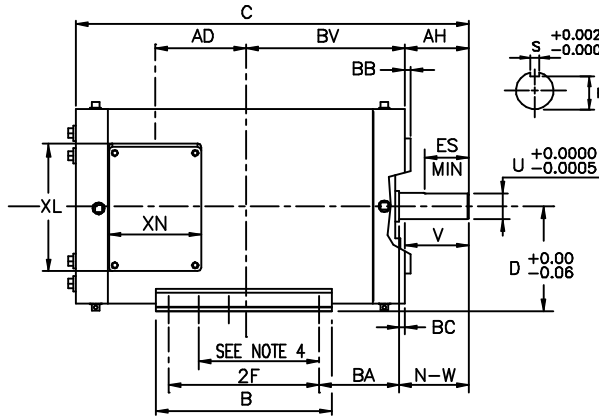
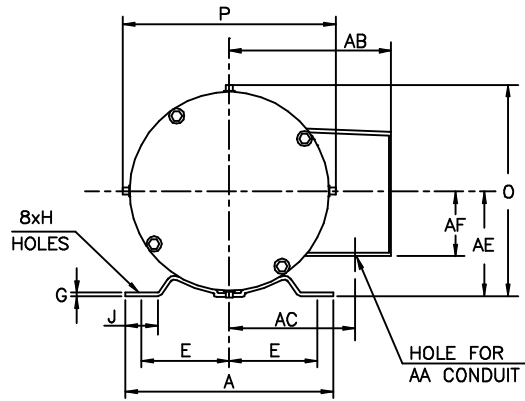

UNITS: INCHES

| FRAME SIZE | MOUNTING |      |      |      | FLANGE |       |       |       |      |      |            |      |
|------------|----------|------|------|------|--------|-------|-------|-------|------|------|------------|------|
|            | E        | 2F   | H    | BA   | AH     | AJ    | AK    | BB    | BC   | BD   | BF TAP     | BV   |
| 56C        | 2.44     | 3.00 | 0.34 | 2.75 | 2.06   | 5.875 | 4.500 | 0.177 | 0.19 | 6.48 | 3/8"-16UNC | 8.33 |

| FRAME SIZE | MOTOR DIMENSIONS |      |      |      |      |      |      |     | CONDUIT BOX |      |     |     |      |      |      |
|------------|------------------|------|------|------|------|------|------|-----|-------------|------|-----|-----|------|------|------|
|            | A                | B    | C    | D    | G    | J    | O    | P   | AA          | AB   | AC  | AE  | AF   | XL   | XN   |
| 56C        | 6.93             | 5.87 | 13.4 | 3.50 | 0.12 | 1.58 | 7.05 | 7.1 | 0.75        | 5.38 | 4.6 | 3.5 | 2.17 | 4.14 | 3.07 |

| FRAME SIZE | SHAFT EXTENSION |      |       | KEY SEAT |       |      | BEARINGS |          | MAXIMUM WEIGHT |
|------------|-----------------|------|-------|----------|-------|------|----------|----------|----------------|
|            | N-W             | V    | U     | R        | S     | ES   | LS       | OS       |                |
| 56C        | 1.88            | 1.63 | 0.625 | 0.517    | 0.188 | 1.41 | 6205UUC3 | 6205UUC3 | 60 lbs.        |

- NOTES:
1. DIMENSION V REPRESENTS LENGTH OF STRAIGHT PART OF SHAFT.
  2. CONDUIT BOX MAY BE ROTATED IN 180° INCREMENTS.
  3. KEY DIMENSIONS EQUAL S x S x 1.38 (MOTOR SUPPLIED WITH KEY)
  4. MOTOR WEIGHT SHOWN IS MAXIMUM HORSEPOWER IN FRAME.

ALL DATA SUBJECT TO CHANGE WITHOUT NOTICE FOR CONSTRUCTION USE ONLY CERTIFIED DATA

CERTIFIED DATA

CUSTOMER: \_\_\_\_\_ P.O. NO.: \_\_\_\_\_ TAG NO.: \_\_\_\_\_  
 MOTOR MODEL NO.: \_\_\_\_\_ TOSHIBA FILE NO.: \_\_\_\_\_  
 HP: \_\_\_\_\_ RPM (SYN.): \_\_\_\_\_ VOLTAGE: \_\_\_\_\_ Hz: \_\_\_\_\_  
 FRAME SIZE: \_\_\_\_\_ LOG NO.: \_\_\_\_\_ LOG REV. LEVEL: \_\_\_\_\_  
 REMARKS: \_\_\_\_\_  
 \_\_\_\_\_  
 PER: \_\_\_\_\_ ISSUE DATE: \_\_\_\_\_ SUPERSEDES: \_\_\_\_\_

*TOSHIBA/HOUSTON*

**TOTALLY-ENCLOSED  
NO-VENTILATION  
FOOT-MOUNTED  
WITH C-FACE FLANGE  
56C  
TOSHWASH S.S.**