

---

ADJUSTABLE SPEED DRIVE  
TRUE TORQUE CONTROL SERIES

---

# TOSHIBA



# TOSVERT-130

# TRANSISTOR INVERTER

*230, 460, and 600 Volt Ratings*

---

OPERATION MANUAL

---

February, 1998  
Part #45086-005



CE

**IMPORTANT NOTICE**

The instructions contained in this manual are not intended to cover all of the details or variations in equipment, nor to provide for every possible contingency to be met in connection with installation, operation, or maintenance. Should additional information be desired or should particular problems arise which are not covered sufficiently for the purchaser's purposes, the matter should be referred to the local Toshiba sales office.

The contents of this instruction manual shall not become a part of or modify any prior or existing agreement, commitment, or relationship. The sales contract contains the entire obligation of Toshiba International Corporation's Adjustable Speed Drive Division. The warranty contained in the contract between the parties is the sole warranty of Toshiba International Corporation's Adjustable Speed Drive Division and any statements contained herein do not create new warranties or modify the existing warranty.

Toshiba International Corporation reserves the right, without prior notice, to update information, make product changes, or to discontinue any product or service identified in this publication.

**Any electrical or mechanical modification to this equipment, without prior written consent of Toshiba International Corporation, will void all warranties and may void UL listing.**

**AC ADJUSTABLE SPEED DRIVE**

Please complete the Extended Warranty Card supplied with this inverter and return it by prepaid mail to Toshiba. This activates the extended warranty. If additional information or technical assistance is required, call Toshiba's marketing department toll free at (800) 231-1412 or write to: Toshiba International Corporation, 13131 W. Little York Road, Houston, TX 77041-9990.

For your records, complete the following information about the drive with which this manual was shipped.

G3 Model Number: \_\_\_\_\_

G3 Serial Number: \_\_\_\_\_

Date of Installation: \_\_\_\_\_

Inspected By: \_\_\_\_\_

Name of Application: \_\_\_\_\_

## INTRODUCTION

Thank you for purchasing the G3 adjustable speed drive. This adjustable frequency solid-state AC drive features "True Torque Control" - Toshiba's 'vector algorithm' that enables motors to develop high starting torque and compensates for motor slip. The G3 also features a multi-lingual forty-character LCD display, RS232 port, dynamic braking transistor, and ground fault, overload, and overcurrent protection. These features, combined with built-in special control features such as PID, drooping, trim, and dancer control, make the G3 suitable for a wide variety of applications that require unparalleled motor control and reliability.

It is the intent of this operation manual to provide a guide for **safely** installing, operating, and maintaining the drive. This operation manual contains a section of general safety instructions and is marked throughout with warning symbols. **Read this operation manual** thoroughly before installing and operating this electrical equipment.

**All safety warnings must be followed** to ensure personal safety.

**Follow all precautions** to attain proper equipment performance and longevity.

We hope that you find this operation manual informative and easy to use. For assistance with your G3, for information on our free drive application school, or for information on Toshiba's complete line of **motors, adjustable speed drives, switchgear, instrumentation, uninterruptable power supplies, PLCs, and motor control products**, please call toll free (800) 231-1412 or write to our plant at: Toshiba International Corporation, 13131 W. Little York Road, Houston, TX 77041-9990.

Again, thank you for your purchase of this product.

## GENERAL SAFETY INSTRUCTIONS

Warnings in this manual appear in either of two ways:

- 1) *Danger warnings* - The danger warning symbol is an exclamation mark enclosed in a triangle which precedes the 3/16" high letters spelling the word "DANGER". The Danger warning symbol is used to indicate situations, locations, and conditions that can cause serious injury or death:



- 2) *Caution warnings* - The caution warning symbol is an exclamation mark enclosed in a triangle which precedes the 3/16" high letters spelling the word "CAUTION". The Caution warning symbol is used to indicate situations and conditions that can cause operator injury and/or equipment damage:



Other warning symbols may appear along with the *Danger* and *Caution* symbol and are used to specify special hazards. These warnings describe particular areas where special care and/or procedures are required in order to prevent serious injury and possible death:

- 1) *Electrical warnings* - The electrical warning symbol is a lightning bolt mark enclosed in a triangle. The Electrical warning symbol is used to indicate high voltage locations and conditions that may cause serious injury or death if the proper precautions are not observed:



- 2) *Explosion warnings* - The explosion warning symbol is an explosion mark enclosed in a triangle. The Explosion warning symbol is used to indicate locations and conditions where molten, exploding parts may cause serious injury or death if the proper precautions are not observed:



For the purpose of this manual and product labels, a **Qualified Person** is one who is familiar with the installation, construction, operation and maintenance of the equipment and the hazards involved. This person must:

- 1) Carefully read the entire operation manual.
- 2) Be trained and authorized to safely energize, de-energize, clear faults, ground, lockout and tag circuits and equipment in accordance with established safety practices.
- 3) Be trained in the proper care and use of protective equipment such as safety shoes, rubber gloves, hard hats, safety glasses, face shields, flash clothing, etc. in accordance with established safety practices.
- 4) Be trained in rendering first aid.

CONTENTS

	<u>PAGE</u>
<b>Disclaimer</b> .....	<b>i</b>
<b>Introduction</b> .....	<b>ii</b>
<b>General Safety Instructions</b> .....	<b>iii</b>
<b>Contents</b> .....	<b>iv-vi</b>
 <b>Section 1 Inspection/Storage/Disposal</b>	
Inspection of the New Unit.....	1-1
Storage .....	1-1
Disposal .....	1-1
 <b>Section 2 Installation and Operation</b>	
Installation Safety Precautions .....	2-1
Operating Safety Precautions.....	2-2
Confirmation of Wiring .....	2-3
Start-up and Test.....	2-4
Maintenance .....	2-4
EMC Installation Guidelines .....	2-5
General EMC Guidelines For Consideration .....	2-7
EU Declaration of Conformity .....	2-8
 <b>Section 3 Specifications</b>	
230 Volt NEMA 1 Chassis Ratings .....	3-1
230 Volt NEMA 4, NEMA12, and Fan/Filter Chassis Ratings.....	3-1
460 Volt NEMA 1 Chassis Ratings .....	3-2
460 Volt NEMA 4, NEMA 12, and Fan/Filter Chassis Ratings.....	3-2
600 Volt NEMA 1 Chassis Ratings .....	3-3
600 Volt type 12 Chassis Ratings.....	3-3
Standard Specifications .....	3-4

**CONTENTS (cont'd)**

	<u>PAGE</u>
<b>Section 4 Wiring</b>	
Standard Connection Diagrams .....	4-1
Selection of Main Circuit Wiring Equipment and Standard Cable Sizes .....	4-4
Grounding .....	4-7
Application Notes: Motor Selection .....	4-7
Connection Examples	
Potentiometer Operation .....	4-8
4-20 mA Reference Operation .....	4-9
Keypad Reference and Remote Stop/Start .....	4-10
RS232 Port .....	4-10
0-10 Volt Reference Operation .....	4-11
 <b>Section 5 Jumper and Terminal Connections</b>	
Terminal Strip Board .....	5-1
Control Board .....	5-2
Terminal Connections and Functions .....	5-3
 <b>Section 6 Operating Panel</b>	
Panel Layout .....	6-1
Keys and Functions .....	6-2
 <b>Section 7 Keypad Functions</b>	
Local Mode .....	7-1
Forward/Rerverse Change .....	7-1
Jog .....	7-1
Coast Stop .....	7-2
Programming Mode .....	7-2
Remote Mode .....	7-2
ESTOP .....	7-2
Other: Language Selection .....	7-2
Monitor Mode .....	7-3
Monitoring "RR" Input Special Function .....	7-4
Monitoring During Pattern Run .....	7-4

**CONTENTS (cont'd)**

	<u>PAGE</u>	
<b>Section 8 Programming Charts</b>		
Fundamental Parameters #1 .....	8-1	
Fundamental Parameters #2 .....	8-2	
Panel Control Parameters .....	8-3	
Special Control Parameters .....	8-4	
Terminal Selection Parameters .....	8-5	
Frequency Setting Parameters .....	8-8	
Protection Parameters .....	8-13	
Pattern Run Control Parameters .....	8-16	
Feedback Parameters .....	8-22	
Communication Setting Parameters .....	8-24	
Industrial Application Parameters (Pump) .....	8-26	
Industrial Application Parameters (Fan) .....	8-26	
Industrial Application Parameters (Conveyor) .....	8-26	
Industrial Application Parameters (Hoist) .....	8-26	
Industrial Application Parameters (Textiles) .....	8-26	
Industrial Application Parameters (Machine Tools) .....	8-26	
AM/FM Terminal Adjustment Parameters .....	8-27	
Utility Parameters .....	8-28	
Motor Parameters .....	8-32	
Parameter Tree .....	8-33	
 <b>Section 9 Programming</b>		
Groups .....	9-1	
Blinding .....	9-2	
Search Function .....	9-2	
Parameter Explanations .....	9-3	
Programming Examples .....	9-30	
 <b>Section 10 Service</b>		
Requesting After Sales Service .....	10-1	
Parts Service Life .....	10-2	
Troubleshooting .....	10-3	
How to Clear a Fault .....	10-3	
G3 Fault Displays and Explanations .....	10-3	
G3 Warning Explanations .....	10-7	
 <b>Section 11 Dimensions/Weights</b>		
Basic Dimensions .....	11-1	
Shipping Weights .....	11-5	
G3 Options .....	11-6	
Keypad Cutout .....	11-7	
 <b>Section 12 Index</b> .....		12-1

## SECTION 1: Inspection/Storage/Disposal

### Inspection of the New Unit

Upon receipt of the G3, a careful inspection for shipping damage should be made. After uncrating:

- 1) Check the unit for loose, broken, bent or otherwise damaged parts due to shipping.
  
- 2) Check to see that the rated capacity and the model number specified on the nameplate conform to the order specifications.

### Storage

- 1) Store in a well ventilated location and preferably in the original carton if the inverter will not be used immediately after purchase.
  
- 2) Avoid storage in locations with extreme temperatures, high humidity, dust, or metal particles.

### Disposal

Please contact your state environmental agency for details on disposal of electrical components and packaging in your particular area. **Never dispose of electrical components via incineration.**



**SECTION 2: Installation and Operation****Installation Safety Precautions**

- 1) Install in a secure and upright position in a well ventilated location that is out of direct sunlight. The ambient temperature should be between -10° C and 40° C.
- 2) Allow a clearance space of 8 inches (20 cm) for the top and bottom and 2 inches (5 cm) on both sides. For models 2010-2270 and models 4015-4500, the top and bottom clearance can be reduced to 4 inches (10 cm). This space will insure adequate ventilation. Do not obstruct any of the ventilation openings.
- 3) Avoid installation in areas where vibration, heat, humidity, dust, steel particles, or sources of electrical noise are present.
- 4) Adequate working space should be provided for adjustment, inspection and maintenance.
- 5) Adequate lighting should be available for troubleshooting and maintenance.
- 6) A noncombustible insulating floor or mat should be provided in the area immediately surrounding the electrical system where maintenance is required.

- 7)  **Always ground the unit to prevent electrical shock and to help reduce electrical noise. A separate ground cable should be run inside the conduit with the input, output, and control power cables (See Grounding page 4-7).**

**THE METAL OF CONDUIT IS NOT AN ACCEPTABLE GROUND.**

- 8) Use **lockout/tagout** procedures before connecting three phase power of the correct voltage to input terminals L1, L2, L3 (R, S, T) and connect three phase power from output terminals T1, T2, T3 (U, V, W) to a motor of the correct voltage and type for the application. Size the conductors in accordance with *Selection of Main Circuit Wiring Equipment and Standard Cable Sizes* page 4-4.
- 9) If conductors of a smaller than recommended size are used in parallel to share current then the conductors should be kept together in sets i.e. U1, V1, W1 in one conduit and U2, V2, W2 in another. National and local electrical codes should be checked for possible cable derating factors if more than three power conductors are run in the same conduit.
- 10) Install a molded case circuit breaker (MCCB) between the power source and the inverter. Size the MCCB to clear the available fault current of the power source.
- 11) Use separate metal conduits for routing the input power, output power, and control circuits.
- 12) Installation of drive systems should conform to the *National Electrical Code*, regulations of the *Occupational Safety and Health Administration*, all national, regional or industry codes and standards.
- 13) If the factory provided enclosure is removed from the drive, then it must be provided with an alternate enclosure before operating. The alternate enclosure should be a minimum of NEMA 1.

Installation Safety Precautions (cont'd)



- 14) Do not connect control circuit terminal block return connections marked CC to inverter earth ground terminals marked GND(E). See *Standard Connection Diagrams* page 4-1 and *Terminal Connections and Functions* page 5-3.
- 15) If a secondary Magnetic Contactor (MC) is used between the inverter output and the load, it should be interlocked so the ST-CC terminals are disconnected before the output contactor is opened. If the output contactor is used for bypass operation, it must also be interlocked so that commercial power is never applied to the inverter output terminals (U,V,W).
- 16) Power factor improvement capacitors or surge absorbers must not be installed on the inverter's output.
- 17) **Only qualified personnel should install this equipment.**



Operating Safety Precautions



- 1) Do not power up the inverter until this entire operation manual is reviewed.
- 2) The input voltage must be within +/-10% of the specified input voltage. Voltages outside of this permissible tolerance range may cause internal protection devices to turn on or can cause damage to the unit. Also, the input frequency should be within +/-2 Hz of the specified input frequency.
- 3) Do not use this inverter with a motor whose rated input is greater than the rated inverter output.
- 4) This inverter is designed to operate NEMA B motors. Consult the factory before using the inverter for special applications such as an explosion proof motor or one with a repetitive type piston load.

- 5)  **DANGER** 

Do not touch any internal part with power applied to the inverter; first remove the power supply from the drive and wait until charge LED (see page 5-1 for location) are no longer illuminated. **Charged capacitors can present a hazard even if source power is removed.**

- 6)   **DO NOT OPERATE THIS UNIT WITH ITS CABINET DOOR OPEN.**
- 7) Do not apply commercial power to the output terminals T1 (U), T2 (V), or T3 (W) even if the inverter source power is off. Disconnect the inverter from the motor before megging or applying bypass voltage to the motor.
- 8) The PWM carrier frequency is limited to a maximum of 2.2KHz when the inverter has a NEMA TYPE12 enclosure, limited to a maximum of 5KHz in all of the 600 volt inverters, and limited to a maximum of 5KHz in the 460 volt NEMA TYPE4 10 horsepower inverter. **Do not attempt to exceed the inverter's carrier frequency which is shown in the PWM Carrier Frequency adjustment range (see page 8-4).**

## Operating Safety Precautions (cont'd)



## CAUTION

- 9) Interface problems can occur when this inverter is used in conjunction with some types of process controllers. **Signal isolation may be required to prevent controller and/or inverter malfunction** (contact Toshiba or the process controller manufacturer for additional information about compatibility and signal isolation).
- 10) Do not open and then re-close a secondary magnetic contactor (MC) between the inverter and the load unless the inverter is OFF (output frequency has dropped to zero) and the motor is not rotating. **Abrupt re-application of the load while inverter is on or while motor is rotating can cause inverter damage.**
- 11) Use caution when setting output frequency. Overspeeding a motor can decrease its torque-developing ability and can result in damage to the motor and/or driven equipment.
- 12) Use caution when setting the acceleration and deceleration time. Unnecessarily short times can cause tripping of the drive and mechanical stress to loads.
- 13) High carrier frequency operation is not available on the G3-4080. Customers requiring high carrier frequencies should consult the factory.
- 14) **Only qualified personnel should have access to the adjustments and operation of this equipment.** They should be familiar with the drive operating instructions and with the machinery being driven.
- 15) **Only properly trained and qualified personnel should be allowed to service this equipment. See page iii.**
- 16) **Follow all warnings and precautions. Do not exceed equipment ratings.**

## Confirmation of Wiring



## CAUTION

Make the following final checks before applying power to the unit:

- 1) Confirm that source power is connected to terminals L1, L2, L3 (R, S, T). **Connection of incoming source power to any other terminals will damage the inverter.**
- 2) The 3-phase source power should be within the correct voltage and frequency tolerances.
- 3) The motor leads must be connected to terminals T1, T2, T3 (U, V, W).
- 4) Make sure there are no short circuits or inadvertent grounds and tighten any loose connector terminal screws.

## Start-Up and Test



**Prior to releasing an electrical drive system for regular operation after installation, the system should be given a start-up test by qualified personnel.** This assures correct operation of the equipment for reasons of reliable and safe performance. It is important to make arrangements for such a check and that time is allowed for it.

When power is applied for the first time, the inverter's parameters are set to the values listed as "FACTORY SETTING" in the charts starting on page 8-1. If these settings are not optimal for the application, program the desired settings before initiating a run. **The inverter can be operated with no motor connected.** Operation with no motor connected or use with a small trial motor is recommended for initial adjustment or for learning to adjust and operate the inverter.

## Maintenance



- 1) Use **lockout/tagout procedures** in accordance with local electrical codes before performing any inverter maintenance.
- 2) Periodically check the operating inverter for cleanliness.
- 3) Do not use liquid cleaning agents.
- 4) Keep the heatsink free of dust and debris.
- 5)  Periodically check electrical connections for tightness (**with power off, locked out, and with charge LED out (see page 5-1 for location)**).

## EMC Installation Guidelines

In order to help our customers comply with European electromagnetic compatibility standards, Toshiba has developed the following guide. All relevant apparatus placed on the European market is required to comply to the European Community directive on electromagnetic compatibility (EMC). The following instructions provide a means of compliance for the G3 series of inverters. A technical construction file (TCF) indicates the rationale used to declare compliance.

The inverters listed in the Filter Selection Chart below have been shown to conform to the following product specifications:

Radiated Interference	: EN 55011 Group 1 Class A
Mains Interference	: EN 55011 Group 1 Class A
Radiated Susceptibility	: IEC 801-3 1984
Conducted RFI Susceptibility	: prEN55101-4 (prIEC801-6) Doc. 90/30270
Electrostatic Discharge	: IEC801-2 1991
Electrical Fast Transient	: IEC 801-4 1988
Surge	: IEC1000-4-5 1995 2 KV line to line, 4 KV line to earth
Voltage Interruption	: IEC 1000-4-11

<b>Filter Selection Chart</b>	
<b>Inverter</b>	<b>Filter</b>
VT130G3U4015	FN258 - 7 / 07
VT130G3U4025	FN258 - 7 / 07
VT130G3U4035	FN258 - 7 / 07
VT130G3U4055	FN258 - 16 / 07
VT130G3U4080	FN258 - 16 / 07
VT130G3U4110	FN258 - 30 / 07 *
VT130G3U4160	FN258 - 30 / 07
VT130G3U4220	FN258 - 42 / 07 *
VT130G3U4270	FN258 - 55 / 07
VT130G3U4330	FN258 - 55 / 07
VT130G3U4400	FN258 - 75 / 34
VT130G3U4500	FN258 - 100 / 35
VT130G3U4600	FN258 - 100 / 35
VT130G3U4750	FN258 - 130 / 35
VT130G3U410K	FN258 - 180 / 35
VT130G3U412K	FN258 - 130 / 35 x 2 **

\* note: based on 110% rating

\*\* note: use filters in parallel

A combination of good grounding (earth) and shielding will yield the best results. In order to make a G3 EMC compliant, an input filter and ferrite bead (part number FN251.005) are required and are available through your Toshiba distributor or Toshiba International (Europe) LTD. (0181-8484466). See above Filter Selection Chart for the suggested input filters. Drives should be installed according to the following installation guidelines in order to maximize electromagnetic compatibility.

## EMC Installation Guidelines (cont'd)

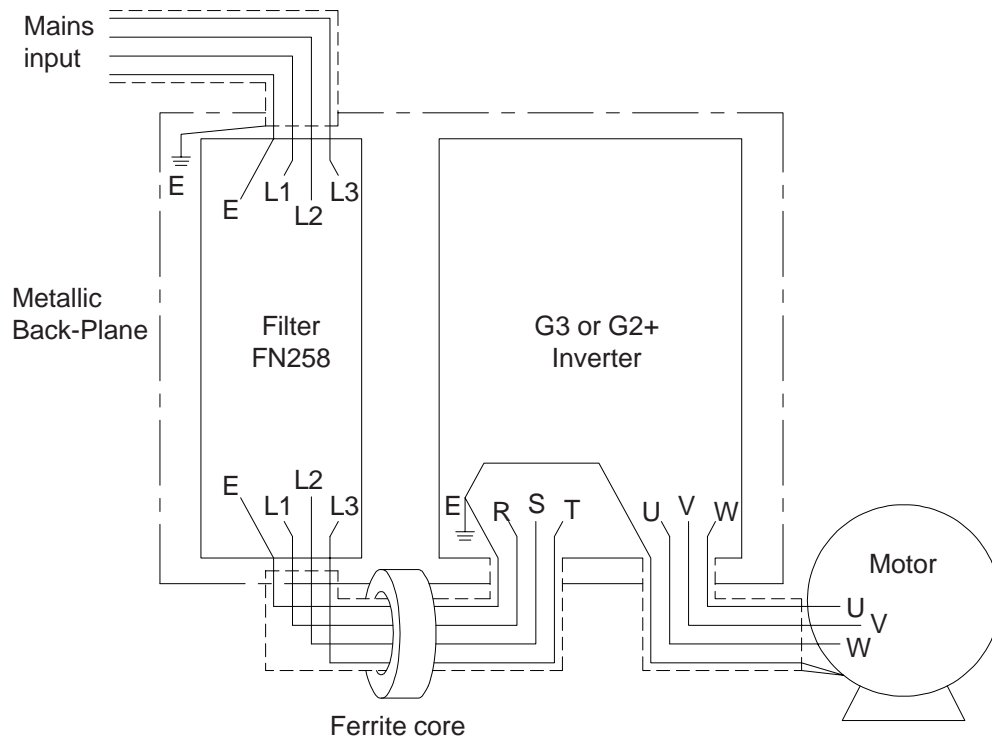

- 1) **Mechanical**  
The inverter and associated equipment should be mounted on a flat metallic back-plane. A minimum space of 2 inches should be left between the drive and filter to allow for ventilation. The filter output cable is to be connected from the bottom of the filter to the inverter power input and is to be as short as possible.
- 2) **Filtering**  
A Schaffner FN258 series input filter of the appropriate current rating should be mounted next to the drive. The filter output must be screened. A single ferrite bead (Schaffner 251-005 or equivalent) must be placed around the filter output, ground, and screen collectively.
- 3) **Cabling**  
The power, filter, and motor cables should be of the appropriate current rating and connected in accordance with suggested manufacturer, local, and national guidelines. 4-core screened cable (such as RS 379-384) is to be used for the power and earth connections to minimize RF emissions. Control cabling must also be screened (RS 367-347 or similar).
- 4) **Grounding**  
The mains (input) ground will be connected at the ground terminal provided on the filter. The filter and motor should be grounded at the ground terminals provided in the inverter.

## EMC Installation Guidelines (cont'd)

- 5)     Screening  
The mains (input) screen is to be connected to the metallic back-plane at the filter, removing and treating finish coating as required. The screen over the filter output cables, the motor cable screen, and the control wire screens must be connected to the inverter case using glands or conduit connectors. The motor cable screen should be connected to the motor case. When using a braking resistor, the cabling between the resistor and drive should also be screened. This screen should connect to both the inverter enclosure and the resistor enclosure.
  
- 6)     Control cables  
RS-232 cables on G3 inverters must have four turns through one ferrite bead (Chomerics H8FE-1004-AS or equivalent). Ferrite beads are best placed within the inverter enclosure.

### General EMC Guidelines For Consideration

Always provide good grounding. Keep grounds short with low RF impedance. A central ground should provide good results in a complex system. Paint or corrosion can hamper good grounding. Keep control and power cabling separated. Minimize exposed (unscreened) cable. Use 360° screened connections where possible.

EU Declaration of Conformity

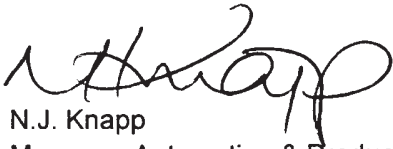
<b>EU DECLARATION OF CONFORMITY WITH COUNCIL DIRECTIVE 73/23/EEC as amended by 93/68/EEC</b>	
<b>Application of Council Directive</b>	: 72/23/EEC Low Voltage Directive on Electrical Safety
<b>Manufacturers Name</b>	: Toshiba International Corporation 13131 West Little York Road Houston, TX 77041 U.S.A.
declares that the product	
<b>Product Name</b>	: Tosvert Models G3 4015 - G3 432K Transistor Inverters operating @ 380-460 VAC, 3-phase. These Inverters provide the variable voltage and frequency output to run induction motors from 1 hp - 325 hp.
<b>Model Number</b>	: VT130G3U4015 - VT130G3U432K
Harmonized Standards Referenced or Applied	
<b>EN61010-1: 1993</b>	Safety requirements for electrical equipment for measurement, control, and laboratory use
<b>prEN50178</b>	Electronic equipment for use in power installations
<i>We hereby certify that the apparatus described above conforms with the protective requirements of Council Directive 73/23/EEC, as modified by Council Directive 93/68/EEC, on the approximation of the laws of the Member States relating to electrical equipment designed for use within certain voltage limits</i>	
July-97	
Doc.ref N:Dsgndata/LVdecg3.xls	N.J. Knapp Manager: Automation & Product Dept.
<b>European Contact</b>	: Toshiba International (Europe) Ltd 1, Roundwood Avenue Stockley Park Uxbridge Middlesex, England UB11 1AR



## SECTION 3: Specifications

### 230 Volt NEMA TYPE 1 Standard Enclosure Ratings

G3		STANDARD RATINGS						
MODEL	NOTES (see below)	RATED KVA	MOTOR HP(KW)	OUTPUT CURRENT (AMPS)	OUTPUT VOLTAGE	OVERLOAD CURRENT	MAIN CIRCUIT INPUT POWER 3-PHASE	INPUT CONTROL POWER
2010	(1, 3)	1	0.75/0.55	3.5	200-230V 3-PHASE MAX VOLTAGE	150% FOR 120 SEC. 110% CONTINUOUS	200V/50Hz or 200-230V/60Hz VOLTAGE +/- 10% FREQ. +/- 2Hz	NO EXTERNAL CONTROL POWER SOURCE REQUIRED
2015	(1, 3)	1.5	1/0.75	5				
2025	(1, 3)	2.5	2/1.5	7				
2035	(1, 3)	3.5	3/2.2	10				
2055	(1, 3)	5.5	5/3.7	16				
2080	(1, 3, 5)	8	7.5/5.5	22				
2110	(1, 2, 5)	11	10/7.5	30				
2160	(1, 2, 5)	16	15/11	45				
2220	(1, 2, 5)	22	20/15	60				
2270	(1, 2, 5)	27	25/18	70				
2330	(1, 4, 5)	33	30/23	90				

NOTES:

- 1) UL/CUL (Underwriters Laboratories Inc.) listed.
- 2) Available with NEMA TYPE 12 UL listing (see 460 Volt NEMA TYPE 12, 4 chart below for output current).
- 3) Available with NEMA TYPE 4 UL listing (see 460 Volt NEMA TYPE 12, 4 chart below for output current).
- 4) Available with fan/filter option kit (same output current).
- 5) Available with optional DC bus inductor (DCL cannot be used with NEMA TYPE 4, 12 or fan/filter kit).

### 230 Volt NEMA TYPE 12 and NEMA TYPE 4 Enclosure Ratings

G3		STANDARD RATINGS						
MODEL	NOTES (see below)	RATED KVA	MOTOR HP(KW)	OUTPUT CURRENT (AMPS)	OUTPUT VOLTAGE	OVERLOAD CURRENT	MAIN CIRCUIT INPUT POWER 3-PHASE	INPUT CONTROL POWER
2010N4	(1)	1	0.75/0.55	3.5	200-230V 3-PHASE MAX VOLTAGE	150% FOR 120 SEC. 110% CONTINUOUS	200V/50Hz or 200-230V/60Hz VOLTAGE +/- 10% FREQ. +/- 2Hz	NO EXTERNAL CONTROL POWER SOURCE REQUIRED
2015N4	(1)	1.5	1/0.75	5				
2025N4	(1)	2.5	2/1.5	7				
2035N4	(1)	3.5	3/2.2	10				
2055N4	(1)	5.5	5/3.7	16				
2080N4	(1)	8	7.5/5.5	22				
2110N12	(2)	11	10/7.5	28				
2160N12	(2)	16	15/11	42				
2220N12	(2)	22	20/15	54				
2270N12	(2)	27	25/18	68				

NOTES:

- 1) NEMA TYPE 4 UL/CUL enclosure.
- 2) NEMA TYPE 12 UL/CUL enclosure.

# TOSHIBA

## 460 Volt NEMA TYPE 1 Standard Enclosure Ratings

G3		STANDARD RATINGS						
MODEL	NOTES (see below)	RATED KVA	MOTOR HP(KW)	OUTPUT CURRENT (AMPS)	OUTPUT VOLTAGE	OVERLOAD CURRENT	MAIN CIRCUIT INPUT POWER 3-PHASE	INPUT CONTROL POWER
4015	(1, 3)	1.5	1/0.75	2.7	380-460V 3-PHASE MAX VOLTAGE	150% FOR 120 SEC. 110% CONTINUOUS	380V/50Hz or 400-460V/60Hz VOLTAGE +/- 10% FREQ. +/- 2Hz	NO EXTERNAL CONTROL POWER SOURCE REQUIRED
4025	(1, 3)	2.5	2/1.5	3.5				
4035	(1, 3)	3.5	3/2.2	5				
4055	(1, 3)	5.5	5/3.7	8				
4080	(1)	8	7.5/5.5	11				
4110	(1, 3, 5)	11	10/7.5	15				
4160	(1, 2, 5)	16	15/11	22				
4220	(1, 2, 5)	22	20/15	30				
4270	(1, 2, 5)	27	25/18.5	38				
4330	(1, 2, 5)	33	30/22	45				
4400	(1, 2, 5)	40	40/30	55				
4500	(1, 2, 5)	50	50/37	69				
4600A	(1, 4, 5)	60	60/45	83				
4750A	(1, 4, 5)	75	75/55	104				
410KA	(1, 4, 5)	100	100/75	138				
412K	(1, 6)	125	125/90	172				
415K	(1, 6)	150	150/110	206				
420K	(1, 6)	200	200/150	275				
425K	(1, 6)	250	250/185	343				
430K	(1, 6)	300	300/220	415				
435K	(1, 6)	350	350/243	447				
						130% FOR 120 SEC. 110% CONTINUOUS		

**NOTES:**

- 1) UL/CUL (Underwriters Laboratories Inc.) listed.
- 2) Available with NEMA TYPE 12 UL listing (see 460 Volt NEMA TYPE 12, 4 chart below for output current).
- 3) Available with NEMA TYPE 4 UL listing (see 460 Volt NEMA TYPE 12, 4 chart below for output current).
- 4) Available with fan/filter option kit (same output current).
- 5) Available with optional DC bus inductor (DCL cannot be used with NEMA TYPE 4, 12 or fan/filter kit).
- 6) Available with optional external DC bus inductor.

## 460 Volt NEMA TYPE 12 and NEMA TYPE 4 Enclosure Ratings

G3		STANDARD RATINGS						
MODEL	NOTES (see below)	RATED KVA	MOTOR HP(KW)	OUTPUT CURRENT (AMPS)	OUTPUT VOLTAGE	OVERLOAD CURRENT	MAIN CIRCUIT INPUT POWER 3-PHASE	INPUT CONTROL POWER
4015N4	(1)	1.5	1/0.75	2.7	380-460V 3-PHASE MAX VOLTAGE	150% FOR 120 SEC. 100% CONTINUOUS	380V/50Hz or 400-460V/60Hz VOLTAGE +/- 10% FREQ. +/- 2Hz	NO EXTERNAL CONTROL POWER SOURCE REQUIRED
4025N4	(1)	2.5	2/1.5	3.5				
4035N4	(1)	3.5	3/2.2	5				
4055N4	(1)	5.5	5/3.7	8				
4080N4	(1)	8	7.5/5.5	11				
4110N4	(1)	11	10/7.5	15				
4160N12	(2)	16	15/11	21				
4220N12	(2)	22	20/15	27				
4270N12	(2)	27	25/18.5	34				
4330N12	(2)	33	30/22	40				
4400N12	(2)	40	40/30	52				
4500N12	(2)	50	50/37	65				

**NOTES:**

- 1) NEMA TYPE 4 UL/CUL enclosure.
- 2) NEMA TYPE 12 UL/CUL enclosure.

## 600 Volt NEMA TYPE 1 Standard Enclosure Ratings

G3		STANDARD RATINGS						
MODEL	NOTES (see below)	RATED KVA	MOTOR HP(KW)	OUTPUT CURRENT (AMPS)	OUTPUT VOLTAGE	OVERLOAD CURRENT	MAIN CIRCUIT INPUT POWER 3-PHASE	INPUT CONTROL POWER
6060	(1, 2, 3)	6	5 (3.8)	6.1	600V 3-PHASE MAX VOLTAGE	150% FOR 120 SEC. 110% CONTINUOUS	575-600V/60Hz 525V/50Hz voltage: +/- 10% freq: +/- 2 Hz	NO EXTERNAL CONTROL POWER SOURCE REQUIRED
6120	(1, 2, 3)	12	10(7.5)	12				
6160	(1, 2, 3)	16	15(11)	17				
6220	(1, 2, 3)	22	20(15)	22				
6270	(1, 2, 3)	27	25(18.5)	27				
6330	(1, 2, 3)	33	30(22)	32				
6400	(1, 2, 3)	40	40(30)	41				
6500	(1, 2, 3)	50	50(37)	52				
6600	(1, 2, 3)	60	60(45)	62				
6750	(1, 2, 3)	75	75(55)	77				
610K	(1, 2, 3)	100	100(75)	99				
612K	(1, 2, 3)	125	125(90)	125				
615K	(1, 3)	150	150(110)	150				
620K	(1, 3)	200	200(150)	200				
625K	(1, 3)	250	250(185)	250				

**NOTES:**

- 1) UL/CUL (Underwriters Laboratories Inc.) listed.
- 2) Available with fan/filter option kit (same output current).
- 3) Available with optional DC bus inductor (DCL option cannot be used with fan/filter kit).

## Standard Specifications

ITEM		STANDARD SPECIFICATIONS
Principal Control Specifications	Control System	Sinusoidal PWM control
	Output voltage regulation	Same as power line.
	Output frequency	0.01 to 400 Hz (0.1 to 80Hz default setting)*. 800 Hz operation possible.
	Frequency setting	0.1Hz from operating panel input (60Hz base), 0.01Hz from analog input (60Hz base, 12-bit/0 to 10Vdc), 0.01Hz from computer interface (60Hz base)
	Frequency accuracy	Analog input: $\pm 0.2\%$ of the maximum output frequency ( $25^{\circ}\text{C}\pm 10^{\circ}\text{C}$ ), Digital input: $\pm 0.01\%$ ( $25^{\circ}\text{C}\pm 10^{\circ}\text{C}$ )
	Voltage/frequency characteristics	Constant V/f, variable torque, automatic torque boost, True Torque Control and automatic energy-saving control/maximum voltage frequency adjustment (25 to 400Hz), torque boost adjustment (0 to 30%), start-up frequency adjustment (0 to 10Hz).
	PWM carrier frequency	Adjustable between 0.5 and 10kHz
	Transistor type	Insulated gate bipolar (IGBT)
	Output voltage regulation	Drive can be programmed to fix max. output volts, let max. float with input voltage, or set max. to input voltage sensed at power-up.
	Dynamic braking	Dynamic braking circuitry installed. External resistor optional.
Frequency	Input signals	3k ohms potentiometer (1k ohm to 10k ohm-rated potentiometer can be connected). 0 to 10Vdc ( $Z_{in}=33k$ ohm), $\pm 10$ Vdc ( $Z_{in}=67k$ ohm), $\pm 5$ Vdc ( $Z_{in}=34k$ ohm), 4 to 20mAdc ( $Z_{in}=500$ ohm)
	Set point control (PID)	Proportional gain, integral gain, anti-hunting gain, lag time constant, and PID error limit adjustments.
Operating functions	Accel/decel time	0.1 to 6000 secs, accel/decel time 1 or 2 selection, accel/decel pattern selection
	Forward or reverse run	Forward run when F-CC closed (default); reverse run when R-CC closed (default); reverse run when both closed (default); coast-stop when ST-CC opened (default); emergency coast stop by a command from operating panel or terminal block; 3-wire control and motorized speed pot programmable functions.
	Jogging run	Jog run from panel with JOG mode selection. Terminal block operation possible with parameter settings.
	Multispeed run	Set frequency plus 15 preset speeds possible with combinations of CC, SS1, SS2, SS3, and SS4 (default functions).
	Retry	When a protective function is activated, the system checks main circuit devices, and attempts to restart. Settable to a maximum of 10 times; wait time adjustment (0 to 10 secs)
	Soft stall	Automatic load reduction during overload (Default setting: OFF).
	Automatic restart	A coasting motor can be smoothly restarted (Default setting: OFF).
	Pattern Run	4 groups of 8 patterns each can be set to the 15 preset speed values. A maximum of 32 different patterns can be run; terminal block control/repetitive run possible.
	DC injection braking	Braking starting frequency adjustment (0 to 120Hz), braking current adjustment (0 to 100%), braking time adjustment (0 to 10secs), emergency stop braking function, motor shaft stationary control.
	Upper/Lower limit	Limits the frequency between the set values (0 to max. frequency). Can be indicated via output contact closure.
	Frequency jump	3 jump frequency settings (each with unique band settings)
	Edit function	Easy access user group containing all changed parameters
	Blind function	Select to display needed parameter groups and parameters
	User-defined defaults	User's parameter values can be saved into a default library. User can then default drive to Toshiba's values or to the user's own.

\* Consult the factory for applications above 80 Hz.

## Standard Specifications (cont'd)

ITEM		STANDARD SPECIFICATIONS
Display	Interface	2-line backlit display LCD 20 characters per line
	Fault display	Overcurrent, overvoltage, heatsink overheat, load-side short-circuit, load-side ground fault, inverter overload, stator overcurrent during start-up, load-side overcurrent during start-up, EEPROM error, RAM error, ROM error, communication error, (dynamic braking unit overcurrent/overload), (emergency stop), (undervoltage), (low current), (overtorque), (open output phase), (motor overload). Items in parenthesis can be selected or deselected.
	Monitor functions	Terminal input/output status, forward/reverse, frequency setting value, output frequency, output current, output voltage, input power, output power, torque current, cumulative run time, past faults, excitation current, DBR overload ratio, inverter overload ratio, motor overload ratio, PID feedback value, DC voltage.
	Selectable units display	Can scale frequency display. Selection of display of current in amps or %, voltage in V or %.
	LED charge indicator	Indicates that the main circuit capacitors are charged
	LED local/remote indicator	Mounted in LOCAL/REMOTE key. Indicates local (keypad) or remote (terminal) control
Inverter/Motor	Protective functions	Soft-stall, current limit, overcurrent, overvoltage, short-circuit at load, load-side ground fault, undervoltage, momentary power failure, regeneration power ride-through, electronic thermal overload protection, main circuit overcurrent at start-up, load-side overcurrent during start-up, DBR resistor overcurrent/overload, heatsink over heat, emergency stop, open output phase.
	Electronic thermal characteristics	Drive's motor overload protection for motor can be adjusted for motor rated amperage. Motor overload has adjustable speed sensitivity. Soft stall on/off. Motor 150% time programmable.
	Reset	Fault reset via keypad, remote contact closure, or programming drive retry. Cycling power also resets fault (fault display can be maintained)
	Regeneration power ride-through control	Some G3 ratings can use regen energy from motor to maintain operation during brown-outs.
Output signals	Fault detection signal	NC/NO form C contact (250VDC, 2A)
	Low speed/reach signals	Dry contacts (250VDC, 2A)
	Upper limit/lower limit	Dry contacts (250VDC, 2A)
	Programmable meter output signals	Pre-compensation reference frequency, post-compensation output frequency, frequency setting value, output current, DC voltage, output voltage, torque current, excitation current, PID feedback value, motor/inverter/DBR overload ratio, input/output power.
	Pulse-train frequency	Open collector output (max. 24 Vdc, 50mA)
	Communication functions	RS232C equipped as standard (connector: modular 6P), RS485, TOSLINE-F10, TOSLINE-F20, RIO, DN, and MB+ are options.
Enclosure	Type	NEMA 1 (available with NEMA 4, NEMA 12, or fan/filter option)
	Cooling method	Forced air cooling . Fan can be automatically stopped when not necessary for extended fan life.
	Color	Sherwin Williams Precision Tan #F63H12
	Service environment	Indoor. Consult factory for elevations above 1000m (requires derate). For example, at 2000m, derate drive FLA by 11%. Must not be exposed to direct sunlight, corrosive and/or explosive gases or mists, fibers and dusts.
	Ambient temperature	From -10°C to 40°C (14°F to 104°F).
	Relative humidity	20 to 95% maximum (non-condensating)
	Vibration	5.9 m/s <sup>2</sup> (0.6G) maximum (10 to 55Hz)
	Climatic class	3K3
	Polution degree	2
IP rating	2X	

**SECTION 4: Wiring**

**Standard Connection Diagrams**

**TOSVERT-130G3  
STANDARD CONNECTION  
MODEL 2010 TO 2330  
MODEL 4015 TO 4270**

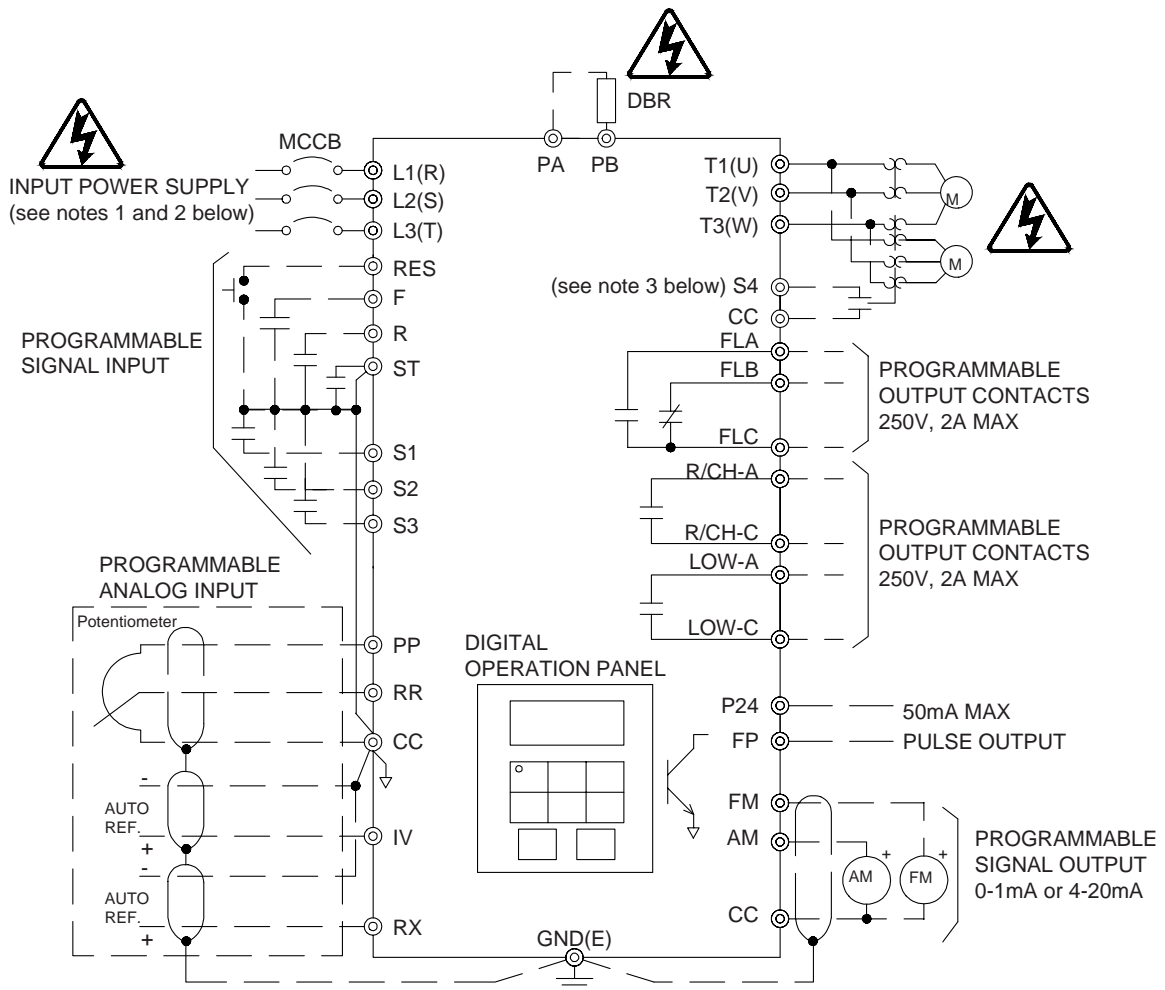

**NOTES:**

- 1.) For inverter models 2010 through 2330 use input power supply of 200VAC, 50Hz or 200-230VAC, 60Hz.
- 2.) For inverter models 4015 through 4270 use input power supply of 380VAC, 50Hz or 400-460VAC, 60Hz.
- 3.) As an example, the "S4" terminal is shown above as an EMERGENCY OFF input. See Section 8 for information on how to program the drive for this and other functions.

Standard Connection Diagrams (cont'd)

**TOSVERT-130G3  
STANDARD CONNECTION  
MODEL 4330 TO 435K**

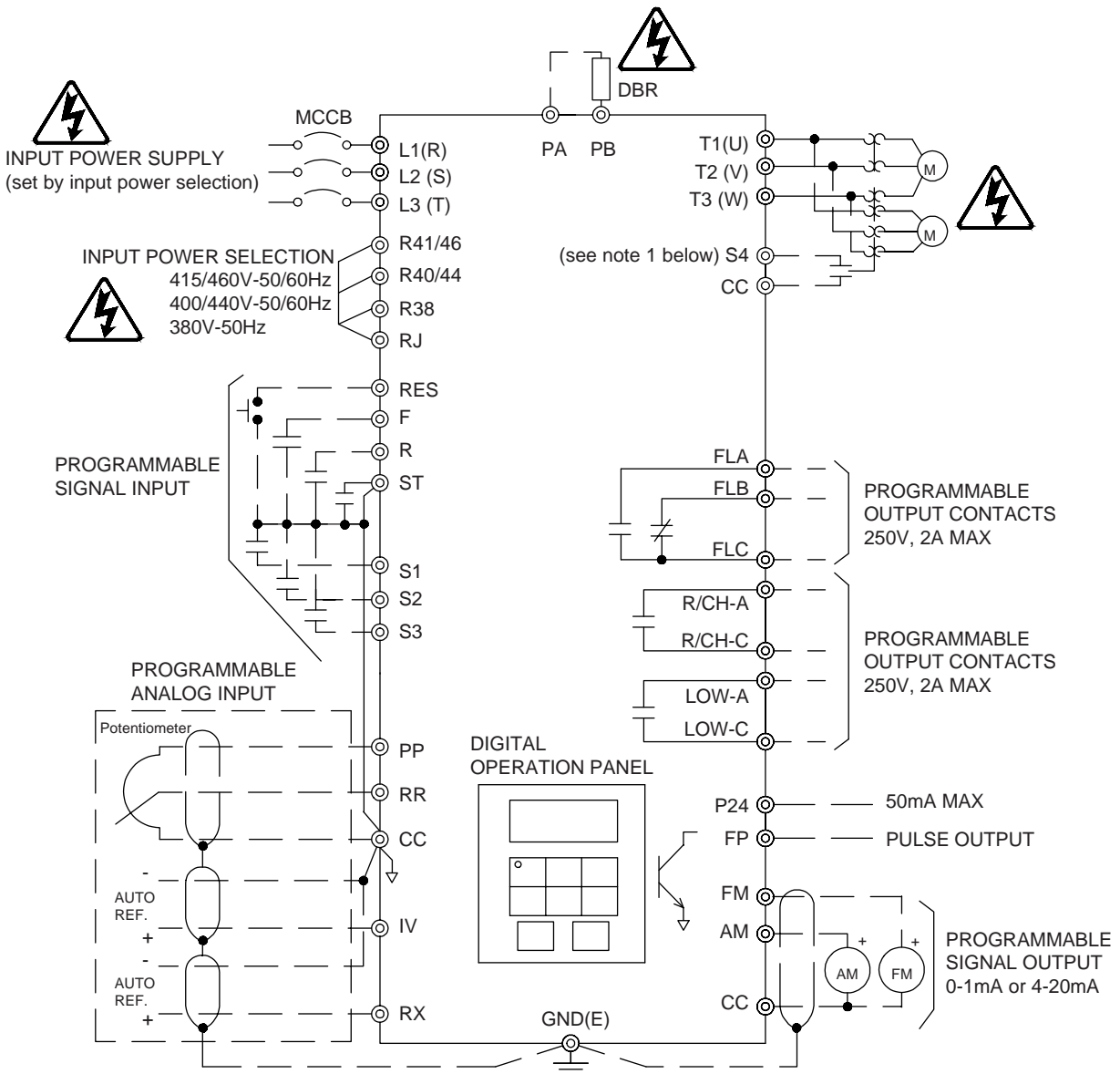

NOTE:

- 1.) As an example, the "S4" terminal is shown above as an EMERGENCY OFF input. See Section 8 for information on how to program the drive for this and other functions.

Standard Connection Diagrams (cont'd)

**TOSVERT-130G3  
STANDARD CONNECTION  
MODEL 6060 TO 625K**

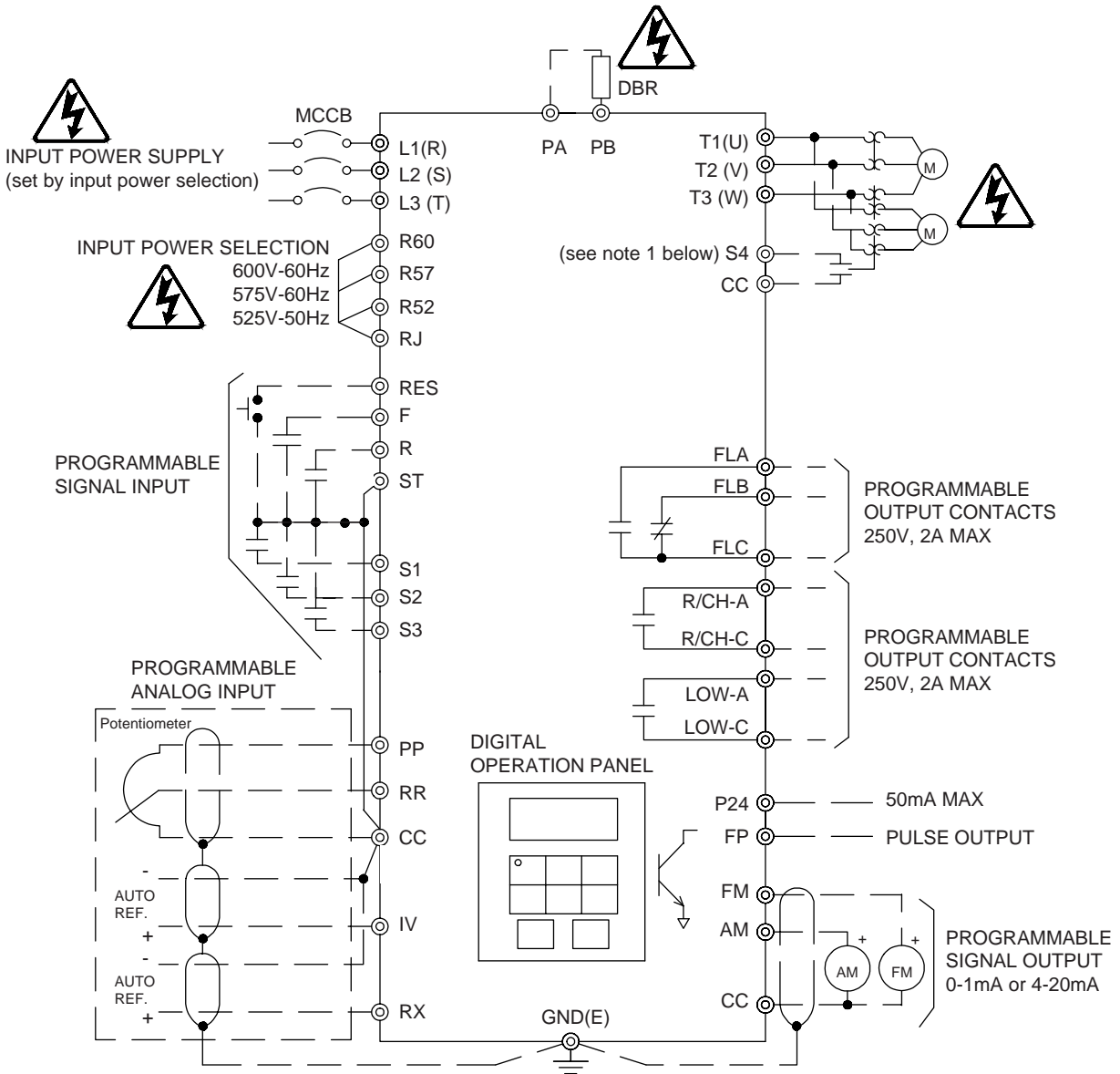

NOTE:

- 1.) As an example, the "S4" terminal is shown above as an EMERGENCY OFF input. See Section 8 for information on how to program the drive for this and other functions.



# TOSHIBA

## Selection of Main Circuit Wiring Equipment and Standard Cable Sizes

Inverter	* Molded case circuit breaker (MCCB)	Ampacity (FLA x 1.25)	** Typical cable size (AWG)				
			Model	Amp rating (A)	(A)	Main power and motor load	**** DB
G3-2010	15	4.4	#14	#14	24-12 / 24-12	3-core shield cable (speed reference) 2-core shield cable #20	#18
G3-2015	15	6.3	#14	#14	24-12 / 24-12		
G3-2025	20	8.8	#14	#14	24-12 / 24-12		
G3-2035	20	12.5	#14	#14	24-12 / 24-12		
G3-2055	30	20.0	#14	#14	24-12 / 24-12		
G3-2080	50	27.5	#10	#14	24-8 / 24-8		
G3-2110	70	37.5	#8	#14	18-2 / 18-2		
G3-2160	90	56.3	#6	#10	18-2 / 18-2		
G3-2220	100	75.0	#4	#10	18-2 / 18-2		
G3-2270	125	87.5	#3	#8	18-2 / 14-2/0		
G3-2330	150	112.5	#2	#8	6-250 / 6-250		
G3-4015	15	3.4	#14	#14	24-12 / 24-12		
G3-4025	15	4.4	#14	#14	24-12 / 24-12		
G3-4035	15	6.1	#14	#14	24-12 / 24-12		
G3-4055	15	10.0	#14	#14	24-12 / 24-12		
G3-4080	30	13.8	#14	#14	24-8 / 24-8		
G3-4110	30	18.8	#14	#14	24-8 / 24-8		
G3-4160	40	27.5	#10	#14	18-2 / 14-2		
G3-4220	50	37.5	#8	#14	18-2 / 14-2		
G3-4270	70	47.5	#8	#14	18-2 / 14-2		
G3-4330	90	56.3	#6	#12	18-2 / 14-2		
G3-4400	100	68.8	#4	#10	18-2 / 14-2		
G3-4500	100	86.1	#3	#8	18-2 / 14-2		
G3-4600	125	103.8	#2	#6	6-250 / 6-250		
G3-4750	175	130.0	#1	#6	6-250 / 6-250		
G3-410K	200	172.5	#2/0	#4	6-250 / 6-250		
G3-412K	225	215.0	#4/0	#3	6-250 / 6-250		
G3-415K	300	257.5	*** 2 (#2/0)	#2	6-250 / 6-250		
G3-420K	350	343.8	*** 2 (#4/0)	#1/0	6-250 / 6-250		
G3-425K	400	428.8	*** 2 (#4/0)	#3/0	6-250 / 6-250		
G3-430K	600	518.8	*** 2(#350)	#4/0	1/0-500 / 1/0-500		
G3-435K	700	558.8	*** 2(#400)	#4/0	1/0-500 / 1/0-500		

See page 4-6 for notes.

# TOSHIBA

## Selection of Main Circuit Wiring Equipment and Standard Cable Sizes (cont'd)

Inverter	* Molded case circuit breaker (MCCB)	Ampacity (FLA x 1.25)	** Typical cable size (AWG)				
			Model	Amp rating (A)	(A)	Main power and motor load	**** DB
G3-6060	15	7.7	#14	#14	24-12 / 24-12	3-core shield cable (speed reference) 2-core shield cable #20	#18
G3-6120	30	15	#12	#14	24-8 / 24-8		
G3-6160	35	21.3	#12	#14	18-2 / 14-2		
G3-6220	50	27.5	#10	#14	18-2 / 14-2		
G3-6270	60	33.8	#8	#14	18-2 / 14-2		
G3-6330	70	40	#8	#14	18-2 / 14-2		
G3-6400	90	51.3	#6	#14	18-2 / 14-2		
G3-6500	100	65	#4	#12	18-2 / 14-2		
G3-6600	100	77.5	#4	#12	6-250 / 6-250		
G3-6750	125	96.3	#2	#12	6-250 / 6-250		
G3-610K	175	123.8	#1/0	#8	6-250 / 6-250		
G3-612K	200	156.3	#2/0	#6	6-250 / 6-250		
G3-615K	225	187.5	*** 2 (#2)	#4	6-250 / 6-250		
G3-620K	300	250	*** 2 (#1/0)	#3	6-250 / 6-250		
G3-625K	400	312.5	*** 2 (#2/0)	#2	6-250 / 6-250		

See page 4-6 for notes.

## Selection of Main Circuit Wiring Equipment and Standard Cable Sizes (cont'd)

- \* The customer supplied Molded Case Circuit Breaker (MCCB) or Magnetic Circuit Protector (MCP) should be coordinated with the available short circuit current. The drives are rated for output short circuits capable of delivering fault currents of 200,000A (in all horsepower). The selection of breakers for this table is in accordance with 1987 NEC Article 430.
- \*\* Wire sizing is based upon NEC table 310-16 or CEC Table 2 using 75 deg C cable, an ambient of 30 deg C, cable runs for less than 300 FT., and copper wiring for not more than three conductors in raceway or cable or earth (directly buried). The customer should consult the NEC or CEC wire Tables for his own particular application and wire sizing.
- \*\*\* Use two parallel conductors instead of a single conductor (this will allow for the proper wire bending radius within the cabinet). Use separate conduits for routing parallel conductors. This prevents the need for conductor derating (see note 3 this page).
- \*\*\*\* See page 9-16 for dynamic resistor sizing (cable size calculated for heavy duty resistor sizes).

### Notes:

- 1.) Contacts used to connect G3 terminals should be capable of switching low current signals (i.e. 5 mA).
- 2.) The G3 has internal overload protection which has been calibrated and certified by Underwriters Laboratories Inc. and does not require external motor overload protection.
- 3.) When wiring with parallel conductors, the conductors should be kept together in phase sets with U1, V1, W1 in one conduit and parallel conductors U2, V2, W2 in another conduit. The ground conductor should be in one of these conduits.
- 4.) Twisted pair wiring should be used for external meters connected to AM and FM terminals.
- 5.) For multiple motor applications, a magnetic only MCP should be replaced by a thermal magnetic MCCB. The MCCB should be sized according to  $(1.25 \times \text{largest motor full load amps}) + \text{sum of all other motor full load amps}$  to meet National *Electric Code (NEC)* or *Canadian Electrical Code (CEC)* requirements. Applications featuring multiple motors on one drive require overload protection for each motor.



### CAUTION

Turn off power to the inverter before making any wiring changes to the analog output circuits.



### CAUTION

Use separate conduits for routing incoming power, power to motor, and control conductors. Use no more than three power conductors and a ground conductor per conduit.

**Grounding**

The inverter must be grounded in accordance with Article 250 of the National Electrical Code or Section 10 of the Canadian Electrical Code, Part I and the grounding conductor should be sized in accordance with 1996 NEC Table 250-95 or CEC, Part I Table 16. See Installation Safety Precautions notes 7 and 14.



**CAUTION** Conduit is not a suitable ground for the inverter.

**Motor Selection**

- 1) Exceeding the peak voltage rating or the rise time allowable of the motor insulation system will reduce the life expectancy. To insure good motor insulation life, consult with the motor supplier as to determine motor insulation ratings and allowable maximum output lead distance. Long lead lengths between the motor and the drive may require filters to be added to the drive output.

**Suggested Maximum<sup>1</sup> Output Lead Distance**

AC Motor Voltage	PWM Carrier Frequency	NEMA MG-1-1998 Section IV Part 31 Compliant Motors <sup>2</sup>
230 V	All	1000 ft.
460 V	< = 5 kHz	600 ft.
575 V	> 5 kHz	300 ft.
460 V	< = 5 kHz	200 ft.
575 V	> 5 kHz	100 ft.

<sup>1</sup> For lead lengths that exceed suggested maximum contact Toshiba for application assistance.

<sup>2</sup> Toshiba EQP III, III-XS & EQP III-841 motors incorporate an insulation system that is in compliance with NEMA MG-1-1998 Section IV Part 31.

- 2) Bearing Considerations:
  - A. Motors operating from adjustable speed drive power sources tend to operate at higher temperatures which may increase the need for more frequent lubrication cycles.

## Connection Examples: Potentiometer Operation

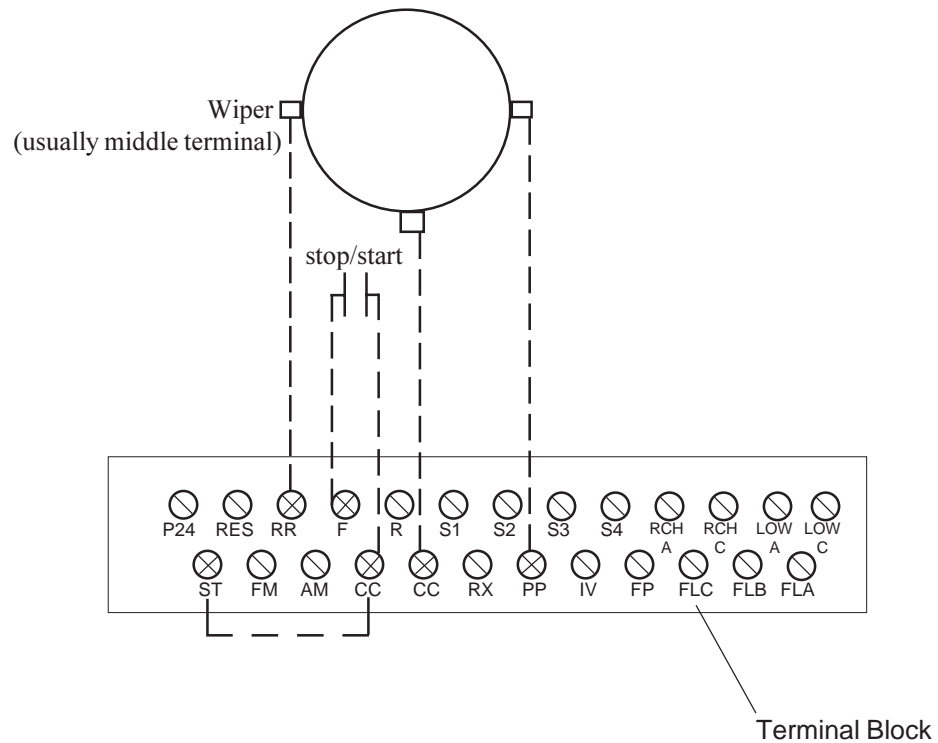

To run from a pot, the G3 must have:

- 1) Drive enable ("ST"- "CC" made)
- 2) Direction command ("F" or "R" to "CC" made)
- 3) Frequency reference ( wiper from pot is read via "RR" terminal )
- 4) LOCAL/REMOTE LED off (puts drive in remote mode).  
Toggle the LOCAL/REMOTE button on keypad to turn LED off (with drive stopped).

Notes:

- 1) Use a 3K ohm pot (1 to 10 K ohms will work).
- 2) The drive will accel to commanded frequency when "F" or "R" to "CC" is made.
- 3) The drive will decel to 0.0 Hz when "F" or "R" to "CC" is broken.
- 4) Motor will coast to a stop if "ST" to "CC" is broken.
- 5) The above information applies to a G3 with factory default programming.

## Connection Examples: 4 - 20mA Reference Operation

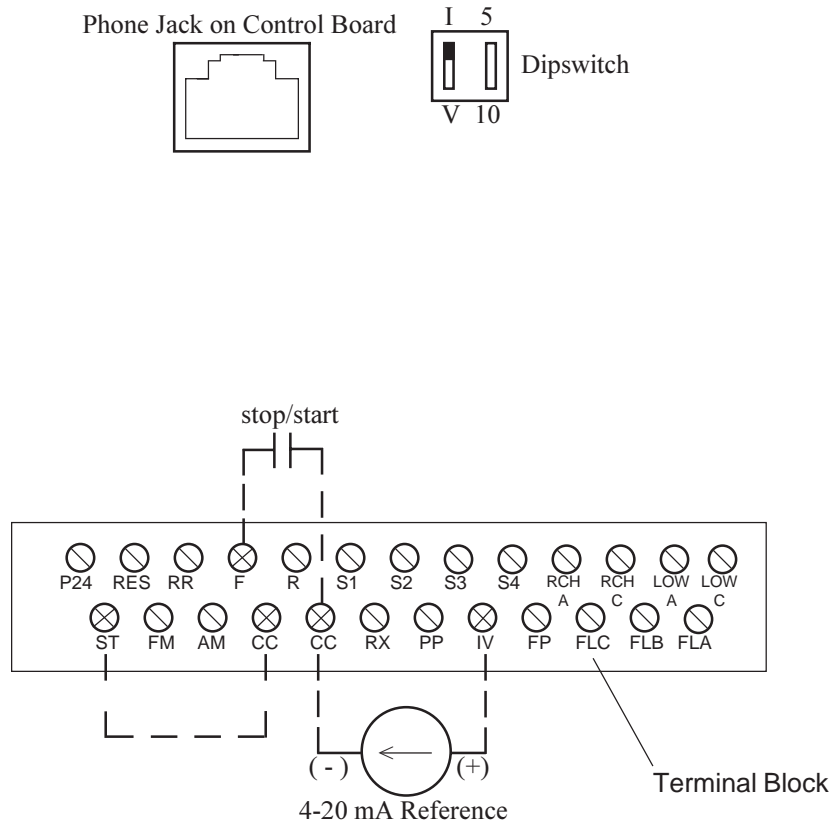

To follow a 4-20 mA signal, the G3 must have:

- 1) "IV" dipswitch to the right of phone jack on control board (immediately under keypad) set to "I" position. "5/10" dipswitch has no effect in this scenario.
- 1) Drive enable ("ST"- "CC" made)
- 2) Direction command ("F" or "R" to "CC" made)
- 3) Frequency reference ( 4-20mA signal at "IV" terminal )
- 4) LOCAL/REMOTE LED off ( puts drive in remote mode)  
 Toggle the LOCAL/REMOTE button on keypad to turn LOCAL/REMOTE LED off.

Notes:

- 1) The drive will accel to the commanded frequency when "F" or "R" to "CC" is made.
- 2) The drive will decel to 0.0 Hz when "F" or "R" to "CC" is broken.
- 3) Motor will coast to a stop if "ST" to "CC" is broken.
- 4) The above information applies to a G3 with factory default programming.
- 5) Do not connect "CC" to ground.

## Connection Examples: Keypad Frequency Reference and Remote Stop/Start

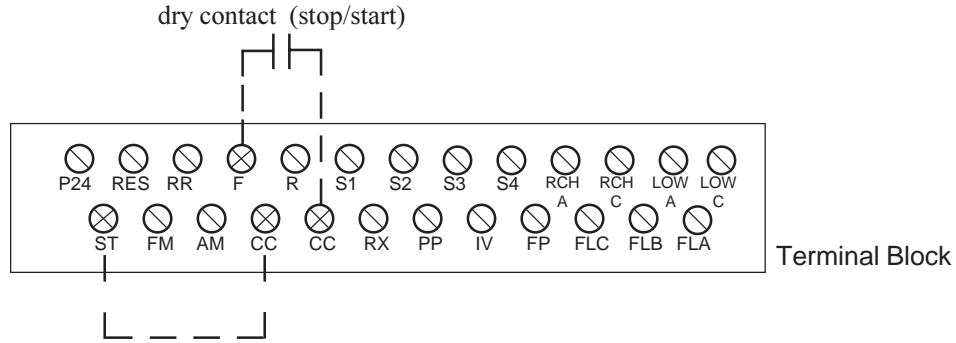

To follow a local (keypad) reference with a remote stop/start, the G3 must have:

- 1) Drive enable ("ST"- "CC" made)
- 2) Direction command ("F" or "R" to "CC" made)
- 3) Frequency reference: Adjust on keypad with arrows. Press READ/WRITE to enter.
- 4) LOCAL/REMOTE LED off ( puts drive in remote mode)  
Toggle the LOCAL/REMOTE button on keypad to turn LED off.
- 5) Programming: Set Item 282, FREQUENCY MODE SELECTION to "2". See page 8-28.

Notes:

- 1) The drive will accel to the commanded frequency when "F" or "R" to "CC" is made.
- 2) The drive will decel to 0.0 Hz when "F" or "R" to "CC" is broken.
- 3) Motor will coast to a stop if "ST" to "CC" is broken.

## Connection Examples: RS232 Port

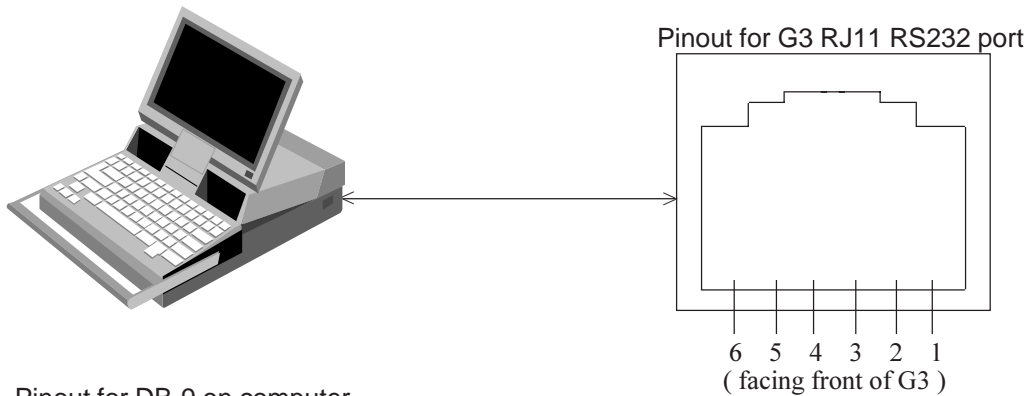

Pinout for DB-9 on computer

(5)	(4)	(3)	(2)	(1)
(9)	(8)	(7)	(6)	

( looking head-on at male connector that plugs into computer )

- Connect DB9 pin 5 to RJ11 pin 3
- Connect DB9 pin 3 to RJ11 pin 4
- Connect DB9 pin 2 to RJ11 pin 2
- Connect DB9 pin 7 to RJ11 pin 6
- Connect DB9 pin 8 to RJ11 pin 1
- Short DB9 pin 6 to DB9 pin 4
- DB9 pin 1 and 9 and RJ11 pin 5 not used

Notes:

- 1) Free RS232 programming/monitoring software is available from Toshiba. Contact your distributor for a copy and manual.
- 2) Do not insert/remove the phone plug into/from the G3 port when drive is powered.
- 3) Common 6 conductor phone cord can be used with an adaptor (6 conductor RJ11 female to DB9 female).  
The adaptor is available from your Toshiba distributor or local electrical supply house.
- 4) "ST"- "CC" must be made.

## Connection Examples: 0-10 volt Reference Operation

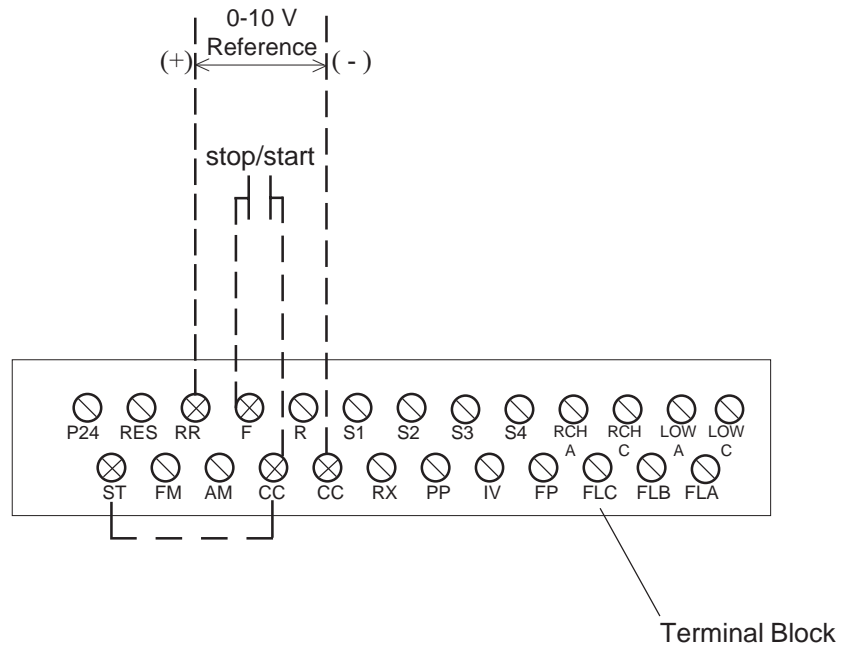

To run from a 0-10 V reference, the G3 must have:

- 1) Drive enable ("ST"- "CC" made)
  - 2) Direction command ("F" or "R" to "CC" made)
  - 3) Frequency reference ( 0-10 V signal applied to "RR" terminal )
  - 4) LOCAL/REMOTE LED off (puts drive in remote mode).
- Toggle the LOCAL/REMOTE button on keypad to turn LED off.

Notes:

- 1) The drive will accel to commanded frequency when "F" or "R" to "CC" is made.
- 2) The drive will decel to 0.0 Hz when "F" or "R" to "CC" is broken.
- 3) Motor will coast to a stop if "ST" to "CC" is broken.
- 4) The above information applies to a G3 with factory default programming.
- 5) Do not connect "CC" to ground.



**SECTION 5: Jumper and Terminal Connections**

**Terminal Board**

The terminal printed wiring board is shown in the detail below. See Section 5.3 for terminal functions. **This board is used in all inverter sizes.**

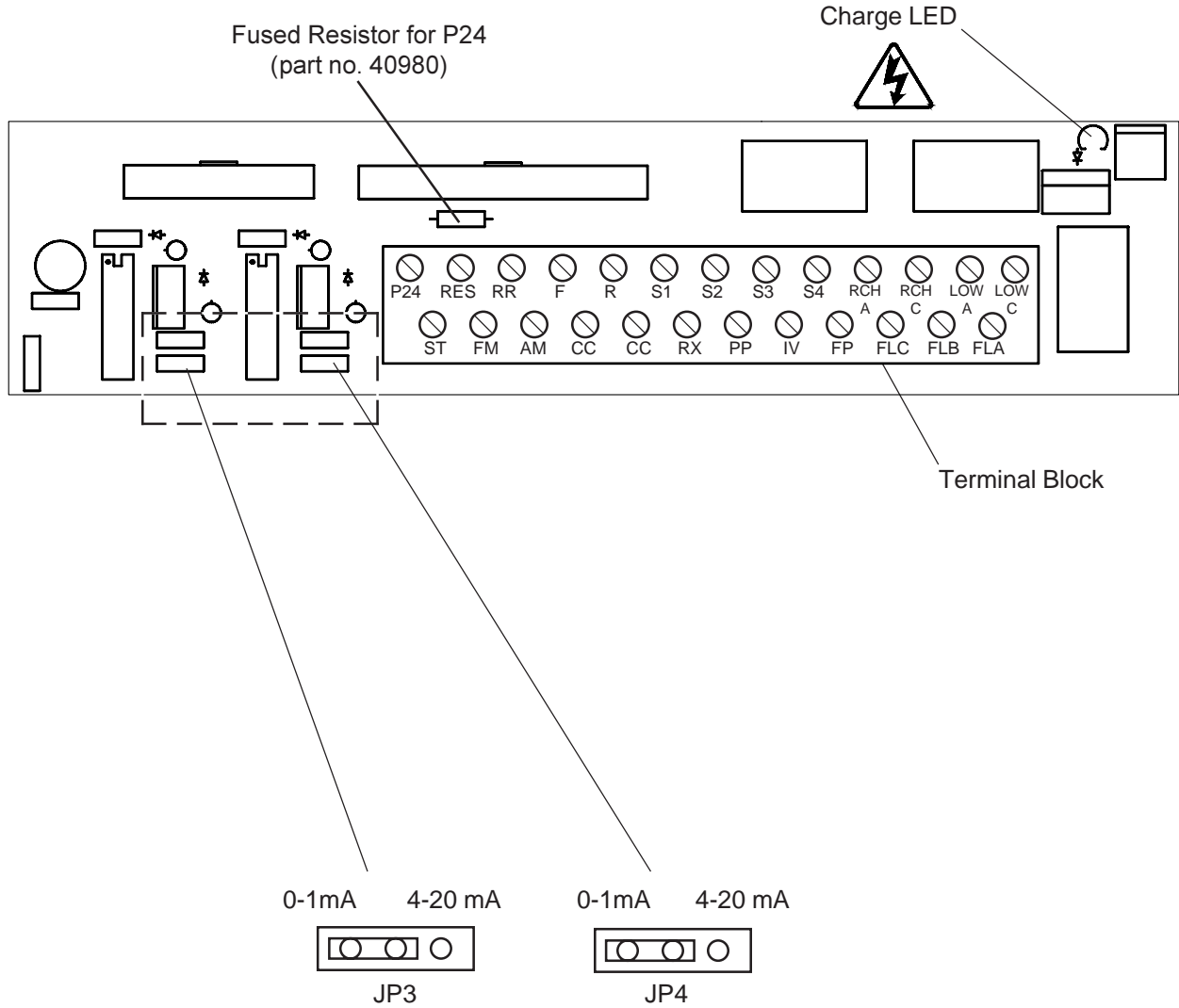

Jumper JP3 is used to set AM terminal and  
 Jumper JP4 is used to set FM terminal.



**CAUTION**

Turn off power to the inverter before connecting or disconnecting any wiring to the terminal block.

**Control Board**

The control printed wiring board is shown in the detail below. **This control board is used in all inverter sizes.**

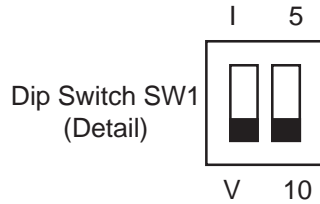
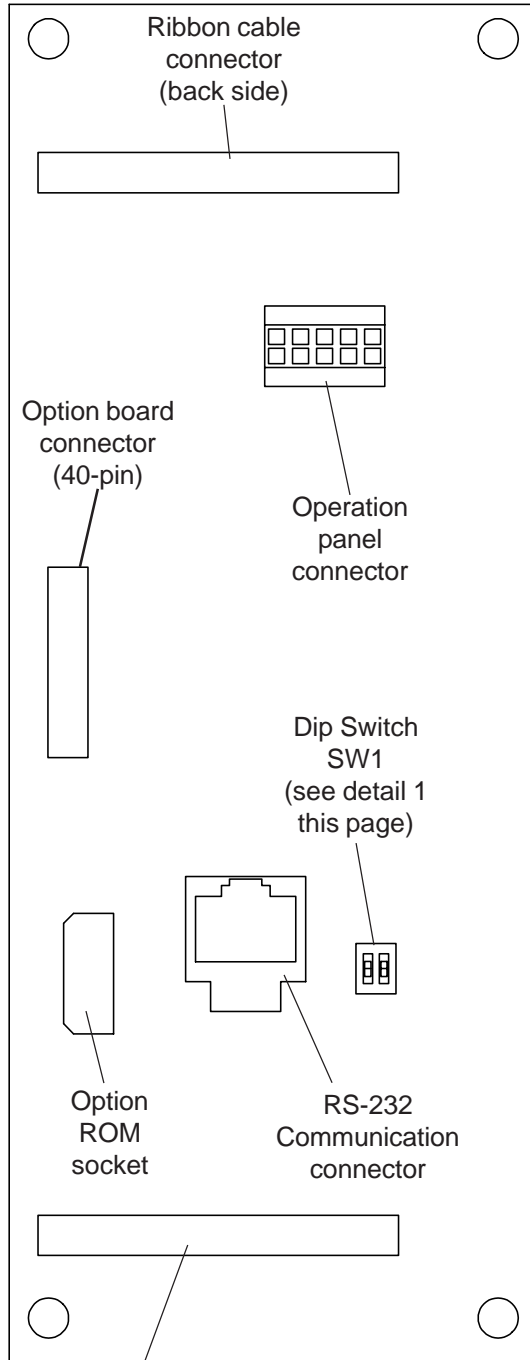

When a 4(0)-20mA reference signal is input to terminal "IV", set switch SW1 to I

When a 0-10 volt reference signal is input to terminal "IV", set SW1 to V

When a +/- 0-5 volt reference signal is input to terminal "RX", set SW1 to 5

When a +/- 0-10 volt reference signal is input to terminal "RX", set SW1 to 10

600 volt G3s are shipped with an option ROM installed

**Make connections to this board only with power off.**

## Terminal Connections and Functions

Terminal name	Terminal functions	Terminal location
L1, L2, L3 (R, S, T)	<p>Line input supply terminals for models G3-2010 to G3-2330: Connect to either 3<math>\phi</math>, 50Hz, 200VAC or 3<math>\phi</math>, 60Hz, 200 to 230VAC.</p> <p>Line input supply terminals for models G3-4015 to G3-435K: Connect to either 3<math>\phi</math>, 50HZ, 400VAC or 3<math>\phi</math>, 60Hz, 400 to 460VAC.</p> <p>Line input supply terminals for models G3-6060 to G3-625K: Connect to either 3<math>\phi</math>, 50HZ, 525VAC or 3<math>\phi</math>, 60Hz, 575 to 600VAC.</p> <p>Drives can be operated on single phase power with when appropriately derated; contact Toshiba distributor for information.</p>	<p>Terminal block or bus bar</p> 
T1, T2, T3 (U, V, W)	<p>Motor output terminals. Connect these terminals to a 3-phase induction motor of the proper voltage, current, and horsepower.</p>	
PA, PB	<p>Braking resistor output terminals. Connect to an external dynamic braking resistor.</p>	
FLA, FLB, FLC	<p>Programmable relay contact output. The contact rating is 250VAC - 2A. Default setting closes FLA-FLC and opens FLB-FLC when protective function has been activated.</p>	<p>Terminal block (See page 5-1)</p>
P24	<p>Unregulated 24Vdc power supply (24Vdc, 50mA maximum). P24 is protected by fused resistor found on the terminal board (see p. 5-1).</p>	
RCH(A & C)	<p>Programmable relay contact output. Standard setting closes contact when an acc/dec is complete, or when the output frequency is within a specified range. Contact rating is 250Vac - 2A.</p>	
LOW(A & C)	<p>Programmable relay contact output. Standard setting closes contact when a preset low speed or a preset lower limit is reached. Contact rating is 250Vac - 2A.</p>	
PP	<p>10 VDC supply typically used to drive potentiometers. Wipers from pots typically connected to "RR" or "RX" terminals.</p>	
FM*	<p>Programmable analog output. Outputs 0 - 1mA or 4 - 20mA (set by JP4 on terminal board (see section 5.1)). This terminal can be connected to an external analog meter. Use either an ammeter rated 1mA DC/20 mA DC at full scale or a voltmeter rated 7.5Vdc at full scale (true analog output). See page 9-23 for programming.</p>	
AM*	<p>Programmable analog output. Outputs 0 - 1mA or 4 - 20mA (set by JP3 on terminal board (see section 5.1)). This terminal can be connected to an external analog meter. Use either an ammeter rated 1mA DC/20 mA DC at full scale or a voltmeter rated 7.5Vdc at full scale (true analog output). See page 9-23 for programming.</p>	
FP	<p>Dedicated open-collector output. Pulses that are 48, 96, or 360-times the output frequency are available according to the parameter settings (must connect external supply through pull-up resistor to measure output).</p>	

\* Do not make/break connections to these terminals with the drive powered.

**Terminal Connections and Functions (cont'd)**

Terminal name	Terminal functions	Terminal location
CC (2-terminals)	This is the common return for all of the input and output terminals. Do not connect this terminal to ground.	Terminal block (See page 5-1)
RR	Programmable analog input. Default setting allows user to input a 0 - 10VDC signal as a frequency command. Input has bias/gain adjustments.	
IV	Programmable analog input. User can input a 0 - 10VDC signal or a 4 - 20 mA DC signal as a frequency command (selection of current or voltage done via dipswitch on control board - see page 5-2). Input has bias gain adjustments.	
RX	Programmable analog input. User can input a +/- 10VDC or a +/- 5VDC signal as a frequency command (see page 5-2). Input has bias/gain adjustments for forward and reverse operation.	
ST	Programmable digital input. With default setting, shorting terminal to "CC" enables drive. Opening "ST" to "CC" coasts motor.	
F	Programmable digital input. With default setting, shorting terminal to "CC" gives drive forward run command. Opening "F" to "CC" decels motor to a stop.	
R	Programmable digital input. With default setting, shorting terminal to "CC" gives drive reverse run command. Opening "R" to "CC" decels motor to a stop.	
S1	Programmable digital input. With default setting, shorting "S1" to "CC" gives drive preset speed frequency reference.	
S2	Programmable digital input. With default setting, shorting "S3" to "CC" gives drive preset speed frequency reference.	
S3	Programmable digital input. With default setting, shorting "S2" to "CC" gives drive preset speed frequency reference.	
S4	Programmable digital input. With default setting, shorting "S4" to "CC" gives drive preset speed frequency reference.	
RES	Programmable digital input. With default setting, shorting "RES" to "CC" resets a tripped drive.	

## SECTION 6: Operating Panel

### Operating Panel Layout



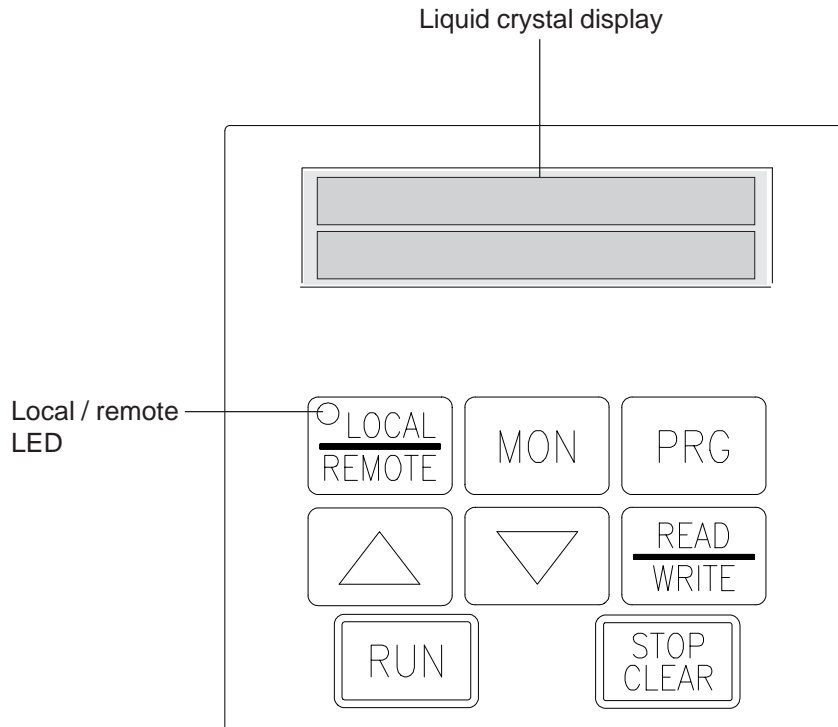





The operating panel enables the user to enable or disable the keypad, input commands from the keypad, and monitor the G3's operation on the liquid crystal display. The panel consists of the keypad, 20 character x 2-line LCD and a LED in the LOCAL/REMOTE button of the keypad. The illustration below shows the operating panel keypad layout and the locations of the keys and display.



## Operating Panel Keys and Functions

The following chart explains each of the key functions on the keypad

### Keys and Functions

Key	Function
	Up scroll key used for incrementing numerical values. Also, when a parameter or group name is displayed, the name of the previous parameter/group can be displayed by pressing this key.
	Down scroll key used for decrementing numerical values. Also, when a parameter or group name is displayed, the name of the next parameter/group can be displayed by pressing this key.
	Used to start a run from the keypad (local control).
	Key changes between the local control mode and the terminal block input control mode operation. When the local control LED in the keypad is "on", operation of the inverter is from the keypad.
	This key functions as the STOP key when running from keypad (local control). In all other modes, emergency off is engaged when this key is pressed twice. During an inverter trip, the tripped state can be reset by pressing this key twice.
	This key is used to enter the monitor mode..
	This key is used to select or enter a parameter name, a parameter value, a frequency command, or a group name.
	This key is used to enter the programming mode.

## SECTION 7: Keypad Operating Functions

This chapter discusses basic keypad operating functions. The keypad allows the user to enter one of four modes: LOCAL, REMOTE, PROGRAMMING, or MONITORING.

### LOCAL MODE

Turn on the power source (MCCB). The drive will display `OUTPUT FREQUENCY 0.0Hz`.

Press the LOCAL/REMOTE button so that the local/remote LED is on. The illuminated LED indicates that the drive is receiving run/stop commands from the keypad (LOCAL mode).

Set the operating frequency pressing the 'up arrow' or 'down arrow' keys. Notice that display changes to `FREQUENCY COMMAND`.

Press READ/WRITE to save frequency. Display changes back to `OUTPUT FREQUENCY`.

When the RUN key is pressed, the G3 will output a frequency that will increase according to the set acceleration time. The panel control LED will blink to indicate motor is running.

When the STOP/CLEAR key is pressed, the G3 outputs a frequency that will decrease according to the set deceleration time. The motor will decelerate and stop.

If the power switch is turned off while the G3 is running a motor, the motor will coast to a stop. This method should be used for emergency stopping only.



### CAUTION

**Avoid frequent starting and stopping of the G3 by turning the (MCCB) power on and off. This will shorten the life of the inverter.**

The output frequency can be changed while running by pressing *up arrow* or *down arrow* key. When one of these keys is pressed the LCD display will blink, indicating that the value is being changed. When the desired frequency is shown on the display, press the READ/WRITE key. The output frequency will change even if the READ/WRITE key is not pressed. However, if power is removed and the READ/WRITE key has not been pressed then the 'new' frequency will be lost because it was not written into the EEPROM.

### LOCAL MODE: FORWARD/REVERSE CHANGE

In LOCAL mode, motor direction can be changed on the fly via the keypad if Item 25, `DIRECTION SELECTION (FORWARD/REV)` is set to "1" (its default):

Press READ/WRITE and *up arrow* at the same time to forward direction command (drive will briefly display `MOTOR RUN DIRECTION: FORWARD`).

Pressing READ/WRITE and *down arrow* at the same time results in a reverse direction command (drive will briefly display `MOTOR RUN DIRECTION: REVERSE`).

Reverse runs can be disabled via Item 5, `REVERSE OPERATION DISABLE` (see page 8-1).

### LOCAL MODE: JOG

To jog from the keypad, program Item 108, `JOG RUN FREQUENCY` and Item 109, `JOG STOP METHOD` as desired (see page 8-9).

In LOCAL mode and with display of `OUTPUT FREQUENCY`, press PRG twice. Drive displays `FORWARD JOG MODE (PRESS RUN)`. Direction can be changed with up/down arrows. Pressing RUN starts jog. Releasing RUN stops jog according to Item 109, `JOG STOP METHOD`.

## LOCAL MODE: COAST STOP

In LOCAL mode, the drive's stop method can be changed to let the motor coast with the following keystrokes.

Keystroke	Display	Comment
	OUTPUT FREQUENCY 60.0 HZ	Standard output frequency display
LOCAL/REMOTE	COAST STOP COMMAND (PRESS STOP)	Drive prompts user for coast stop command
STOP/CLEAR	OUTPUT FREQUENCY 0.0 HZ	Drive immediately stops firing transistors and motor coasts to a stop

## PROGRAMMING MODE

Pressing the PRG button allows users to enter the programming mode. See parameter tree on page 8-33 and parameter charts starting on page 8-1. Parameter explanations and examples can be found in section 9.

## REMOTE MODE

The drive operates in REMOTE mode when the LOCAL/REMOTE LED is not illuminated. The LOCAL/REMOTE LED can be turned on and off with the LOCAL/REMOTE key only when the drive is stopped and at 0.0 Hz. With default programming, the drive powers up in remote mode. In the remote mode, the G3 is stopped/started remotely (e.g. from the terminal strip). To initiate a run, the drive must have:

1. Drive enable ( e.g. "ST"- "CC" made)
2. Frequency command ( e.g. analog input to "IV", "RR", or other terminals)
3. Direction command ( e.g. "R"- "CC" closure or "F"- "CC" closure )

See pages 5-2 and 4-1 for information on physical connections to the drive. See Items 44-55 on page 8-5 for information on the functions available via the input terminals. See Item 281, COMMAND MODE SELECTION and Item 282, FREQUENCY MODE SELECTION for information on how to set where the drive receives start/stop and frequency commands.

## REMOTE MODE: EMERGENCY OFF

EMERGENCY OFF can be executed from the keypad when running and operating in remote mode. EMERGENCY OFF is stored as a past fault in the monitor, but does not change the state of any "fault" contacts. When running in remote mode, press STOP/CLEAR twice to initiate an EMERGENCY OFF command. Drive will stop motor according to method selected in Item 151, EMERGENCY OFF MODE SELECTION.

## OTHER KEYPAD FUNCTIONS: LANGUAGE SELECTION

To change languages, press LOCAL/REMOTE + MON + PRG together with the display showing OUTPUT FREQUENCY. Use the arrows to select the desired language and press WRT to enter. As of 8/97, English and German are supported. German is available on the version 121 keypad ROM. To check keypad ROM number, press and hold the PRG button after pressing the three buttons together as mentioned above. If drive displays "79", the keypad ROM is version 121; if the drive displays "6E", the keypad ROM version is 110. If the drive does nothing, keypad ROM is version 100.



## MONITOR MODE

Pressing the MON key switches the drive to monitor mode. The following table is an example of the drive operation variables visible in the monitor:

Keystroke	Display	Explanation
	OUTPUT FREQUENCY 0.0Hz	Standard output frequency display
MON	MOTOR RUN DIRECTION: FORWARD	Pressing the MON key places inverter in monitor mode. The first monitor window indicates direction.
<i>down arrow</i>	MONITOR #1 0.0 Hz	Programmable monitor #1 (the default shows frequency command)
<i>down arrow</i>	LOAD CURRENT 0%	Programmable monitor #2 (default setting shows total current in percent)
<i>down arrow</i>	INPUT VOLTAGE 228V	Programmable monitor #3 (default setting shows input voltage)
<i>down arrow</i>	OUTPUT VOLTAGE 0V	Programmable monitor #4 (default setting shows output voltage)
<i>down arrow</i>	STATUS: R:-- S1:ON S2:-- S3:ON S4:--	Input terminal monitor. Drive displays "ON" when terminal is shorted to "CC".
<i>down arrow</i>	ST:ON F:-- RES:ON S5:-- S6:ON S7:--	Input terminal monitor. Drive displays "ON" when terminal is shorted to "CC".
<i>down arrow</i>	RCH:ON LOW:ON FL:ON OUT:ON FAN:-- MC:ON	Output contact monitor. Drive displays "ON" when output is energized.
<i>down arrow</i>	CUMULATIVE RUN TIME 0.00	Non-resettable run time monitor. ".01" = 1 hour.
<i>down arrow</i>	PAST TRIP #1 OVERCURRENT (ACCEL)	Past trip #1 monitor
<i>down arrow</i>	PAST TRIP #2 OVERCURRENT (DECEL)	Past trip #2 monitor
<i>down arrow</i>	PAST TRIP #3 OVERVOLTAGE (DECEL)	Past trip #3 monitor
<i>down arrow</i>	PAST TRIP #4 NO ERROR	Past trip #4 monitor
<i>down arrow</i>	MOTOR RUN DIRECTION: FORWARD	Return to the first monitor window

The monitor has no effect on what is happening to the motor and contains information useful for start-ups and troubleshooting. If the down/up arrow key is pressed continuously, every 0.5 seconds the next/previous item will be displayed.

As illustrated above, the monitor displays MONITOR #1, LOAD CURRENT, INPUT VOLTAGE, and OUTPUT VOLTAGE as default. The four variables displayed in these monitor windows are programmable via Items 289-292 (see page 8-30).

Terminals "S6", "S7", and "S8" exist on option boards INV3-COM-B and INV3-COM-D. Terminal "OUT" is an output contact available on option boards INV3-COM-B and INV3-COM-D. "MC" is the soft start resistor bypass contactor (should always show "ON").

Monitor currents can be shown in amps by adjusting Item 296, CURRENT UNITS SELECTION to "1". Monitor voltages can be shown in percent by adjusting Item 297, VOLTAGE UNITS SELECTION to "0".

The monitor's past four faults can be cleared by setting Item 280, STANDARD SETTING MODE SELECTION to "4".

## MONITORING "RR" INPUT SPECIAL FUNCTION

The "RR" terminal can be used to adjust the following drive parameters on the fly: Maximum Output Frequency, accel/decel times, voltage boost, and stall level. When Item 289, 290, 291, or 292 are programmed to "14", one of the drive's monitor windows will display the following:

Setting of Item 79, RR INPUT SPECIAL FUNCTION SELECT	Monitor display
1	With 10 volts on the "RR" terminal, this monitor shows MAXIMUM OUTPUT FREQUENCY. Zero volts on "RR" makes the effective Maximum Output Frequency 30 Hz. See Item 1, MAXIMUM OUTPUT FREQUENCY.
2	This monitor displays the acc/dec multiplier. Zero volts on "RR" results in a display of "1.0". Ten volts on "RR" results in a display of "10.0".
3	This monitor displays the effective voltage boost. Zero volts on the "RR" terminal results in a "0.0" display. At ten volts, VOLTAGE BOOST is displayed.
4	This monitor shows effective Stall Protection Current Level. If Item 296, CURRENT UNITS SELECTION is set to "1", no units will be displayed with the current value.

## MONITORING DURING PATTERN RUN

During a pattern run, the following four windows are added to the monitor sequence:

Key Operation	LCD Message	Explanation
	OUTPUT FREQUENCY 30.0HZ	Standard output frequency display
MON	PATTERN GROUP #1 SPEED #3	Indicates the active pattern group number and current speed used.
<i>down arrow</i>	NUMBER OF CYCLES REMAINING 145	Indicates how many pattern group repetitions are remaining
<i>down arrow</i>	PRESET SPEED # 12	Indicates the preset speed currently used.
<i>down arrow</i>	REMAINING PATTERN TIME 2365 MIN	Indicates the remaining pattern time
<i>down arrow</i>	MOTOR RUN DIRECTION: FORWARD	Beginning of regular monitor windows.

## SECTION 8: Programming Charts

### GROUP : FUNDAMENTAL PARAMETERS #1

LIQUID CRYSTAL DISPLAY	ITEM NO.	PARAMETER DESCRIPTION	ADJUSTMENT RANGE	DISPLAY RESOLUTION	FACTORY SETTING	PAGE NO.
MAXIMUM OUTPUT FREQUENCY	1	Maximum frequency	30 - 400 Hz	0.01/0.1 Hz	80 Hz	9-3
BASE FREQUENCY #1	2	Base frequency #1	25 - 400 Hz	0.01/0.1 Hz	60 Hz	9-3
BASE FREQUENCY VOLTAGE SELECT	3	Base frequency voltage selection	0: Input voltage level 1: Automatic setting 2: Stationary setting	-	1	9-3
MAXIMUM OUTPUT VOLTAGE #1	4	Maximum voltage #1 for 230V Maximum voltage #1 for 460V Maximum voltage #1 for 600V	0 - 255V 0 - 510V 0 - 600V	1V 1V 1V	230V 460V 575V	9-3 9-3 9-3
REVERSE OPERATION DISABLE SELECT	5	Reverse operation disable selection	0: Reverse allowed 1: Reverse not allowed	-	0	9-3
UPPER LIMIT FREQUENCY	6	Upper limit frequency	0.0 Hz - Maximum Output Frequency	0.01/0.1 Hz	80.0	9-3
LOWER LIMIT FREQUENCY	7	Lower limit frequency	0.0 Hz - Upper Limit Frequency	0.01/0.1 Hz	0.0	9-3
VOLTS PER HERTZ PATTERN	8	V/F pattern	1: Constant torque * 2: Variable torque * 3: Automatic torque boost 4: Automatic torque boost with automatic energy savings feature 5: Vector control 6: Vector control with automatic energy savings feature	-	1	9-3
VOLTAGE BOOST #1	9 *	30 HP and less 40 HP and greater	0 - 30%	0.1%	3% 1%	9-4
ACCELERATION TIME #1	10	60 HP and less 75 HP and greater	0.1-6000/0.01-600.0	0.1s/0.01s	10 sec 60 sec	9-4
DECELERATION TIME #1	11	60 HP and less 75 HP and greater	0.1-6000/0.01-600.0	0.1s/0.01s	10 sec 60 sec	9-4
ACC/DEC PATTERN #1 SELECTION	12	Acc/Dec pattern #1	0: Linear 1: Self-adjusting 2: S-Pattern 3: Overspeed Pattern	-	0	9-4
ACCEL/DECEL PATTERN ADJUST LOW	13	Acc/Dec pattern adjustment amounts (low)	0 - 50	1%	25	9-5
ACCEL/DECEL PATTERN ADJUST HIGH	14	Acc/Dec pattern adjustment amounts (high)	0 - 50	1%	25	9-5

\*Item 9 is available only when Item 8 Adjustment Range option 1 or 2 is selected.

**GROUP : FUNDAMENTAL PARAMETERS #2**

LIQUID CRYSTAL DISPLAY	ITEM NO.	PARAMETER DESCRIPTION	ADJUSTMENT RANGE	DISPLAY RESOLUTION	FACTORY SETTING	PAGE NO.
BASE FREQUENCY #2	15	Base frequency #2	25 - 400 Hz	0.01/0.1 Hz	60.0	9-5
MAXIMUM OUTPUT VOLTAGE #2	16	Maximum voltage #2 for 230V Maximum voltage #2 for 460V Maximum voltage #2 for 600V	0 - 255V 0 - 510V 0 - 600V	1V 1V 1V	230V 460V 575V	9-5 9-5 9-5
VOLTAGE BOOST #2	17 *	30 HP and less 40 HP and greater	0 - 30%	0.1%	3% 1%	9-5
ELECTRONIC THERMAL PROTECT LVL #2	18	Electronic thermal protection level #2	10-100% or amps	1%/A	100	9-5
STALL PROTECTION SELECTION #2	19	turn stall #2 on/off	0: On ** 1: Off	-	0	9-5
STALL PROTECTION LEVEL #2	20**	adjust stall current level #2	10-215% or amps	1%/A	150%	9-5
ACCELERATION TIME #2	21	60 HP and less 75 HP and greater	0.1-6000/0.01-600.0	0.1s/0.01s	10 sec 60 sec	9-5
DECELERATION TIME #2	22	60 HP and less 75 HP and greater	0.1-6000/0.01-600.0	0.1s/0.01s	10 sec 60 sec	9-5
ACC/DEC PATTERN #2 SELECTION	23	Acc/Dec pattern #2	0: Linear 1: Self-adjusting 2: S-Pattern 3: Overspeed Pattern	-	0	9-5
ACC/DEC #1/#2 SWITCH FREQUENCY	24	Hz at which to switch from ACC1/DEC1 to ACC2/DEC2	0 - Max. Output Freq. (Item 1)	0.1/0.01 Hz	0.0	9-5

\*Item 17 is available only when Item 8, VOLTS PER HERTZ PATTERN Adjustment Range option 1 or 2 is selected.

\*\*Item 20 is available only when Item 19 Adjustment Range option 0 is selected.

**GROUP: PANEL CONTROL PARAMETERS**

LIQUID CRYSTAL DISPLAY	ITEM NO.	PARAMETER DESCRIPTION	ADJUSTMENT RANGE	DISPLAY RESOLUTION	FACTORY SETTING	PAGE NO.
DIRECTION SELECTION (FORWARD/REV)	25	Forward/reverse	0: Reverse 1: Forward	-	1	9-5
STOP PATTERN SELECTION	26	Stop pattern selection	0: Decelerated stop 1: Coast stop	-	0	9-5
FUNDAMENTAL PARAM SWITCHING	27	Fundamental parameter #1 or #2 selection	1: Fundamental parameter #1 2: Fundamental parameter #2	-	1	9-5
ACCEL/DECEL #1/#2 SELECTION	28	Acc/dec #1 or #2 selection	1: Acc/dec #1 2: Acc/dec #2	-	1	9-6
PANEL RESET SELECTION	29	Panel reset selection	0: All possible 1: Only OL can be reset 2: Only OL, OC1, OC2, OC3 can be reset	-	0	9-6
PANEL FEEDBACK CONTROL	30	Panel feedback control (PID, speed feedback, drooping)	0: On (valid when panel operation is selected) 1: Off (invalid when panel operation is selected)	-	0	9-6

## GROUP : SPECIAL CONTROL PARAMETERS

LIQUID CRYSTAL DISPLAY	ITEM NO.	PARAMETER DESCRIPTION	ADJUSTMENT RANGE	DISPLAY RESOLUTION	FACTORY SETTING	PAGE NO.
START-UP FREQUENCY	31	Start-up frequency	0.0 - 10	0.1/0.01 Hz	0.1	9-6
END FREQUENCY	32	End frequency	0.0 - 30	0.1/0.01 Hz	0.1	9-6
RUN FREQUENCY	33	Run frequency	0.0 - max output freq	0.1/0.01 Hz	0.0	9-6
RUN FREQUENCY HYSTERESIS	34	Run frequency hysteresis	0.0 - 30	0.1/0.01 Hz	0.0	9-6
ENABLE JUMP FREQUENCIES	35	Jump frequency enable	0: Function OFF 1: Function ON *	-	0	9-6
JUMP FREQUENCY #1	36*	Jump frequency #1	0.0-Max Output Freq	0.1/0.01 Hz	0.0	9-6
JUMP FREQUENCY #1 BANDWIDTH	37*	+/- band # 1	0 - 30	0.1/0.01 Hz	0.0	9-7
JUMP FREQUENCY #2	38*	Jump frequency #2	0.0-Max Output Freq	0.1/0.01 Hz	0.0	9-7
JUMP FREQUENCY #2 BANDWIDTH	39*	+/- band # 2	0 - 30	0.1/0.01 Hz	0.0	9-7
JUMP FREQUENCY #3	40*	Jump frequency #3	0.0-Max Output Freq	0.1/0.01 Hz	0.0	9-7
JUMP FREQUENCY #3 BANDWIDTH	41*	+/- band # 3	0 - 30	0.1/0.01 Hz	0.0	9-7
PWM CARRIER FREQUENCY	42	PWM carrier frequency for 230V (.75-30 HP) PWM carrier frequency for 460V (1-125 HP) PWM carrier frequency for 460V (150-325 HP) PWM carrier frequency for 230V and 460V NEMA TYPE4 (.75-7.5 HP) PWM carrier frequency for 460V NEMA TYPE4 (10 HP) PWM carrier frequency for 230V NEMA TYPE12 (10-25 HP) PWM carrier frequency for 460V NEMA TYPE12 (15-50 HP) PWM carrier frequency for 230V with fan/filter kit (30 HP) PWM carrier frequency for 460V with fan/filter kit (60-100 HP) PWM carrier frequency for 600V (5-250 HP)	500 Hz - 10 kHz 500 Hz - 10 kHz 500 Hz - 5 kHz 500 Hz - 10 kHz 500 Hz - 5 kHz 500 Hz - 2.2 kHz 500 Hz - 2.2 kHz 500 Hz - 10 kHz 500 Hz - 10 kHz 500 Hz - 5kHz	0.1kHz	2.2 kHz	9-7

\*Items 36 - 41 are available only when Item 35 Adjustment Range option 1 is selected.

## GROUP: TERMINAL SELECTION PARAMETERS

LIQUID CRYSTAL DISPLAY	ITEM NO.	PARAMETER DESCRIPTION	ADJUSTMENT RANGE	DISPLAY RESOLUTION	FACTORY SETTING	PAGE NO.
INPUT TERMINAL SELECTION	43	Input terminal selection	0: Standard terminal functions 1: custom terminal functions *	-	0	9-7
"R" INPUT TERMINAL FUNCTION	44*	assign function to "R" terminal (default function is reverse run)	0 - 54	-	0	9-7 5-1
"S1" INPUT TERMINAL FUNCTION	45*	assign function to "S1" terminal (default function is preset speed)	0 - 54	-	1	9-7 5-1
"S2" INPUT TERMINAL FUNCTION	46*	assign function to "S2" terminal (default function is preset speed)	0 - 54	-	2	9-7 5-1
"S3" INPUT TERMINAL FUNCTION	47*	assign function to "S3" terminal (default function is preset speed)	0 - 54	-	3	9-7 5-1
"S4" INPUT TERMINAL FUNCTION	48*	assign function to "S4" terminal (default function is preset speed)	0 - 54	-	4	9-7 5-1
"F" INPUT TERMINAL FUNCTION	49*	assign function to "F" terminal (default function is forward run)	0 - 54	-	5	9-7 5-1
"RES" INPUT TERMINAL FUNCTION	50*	assign function to "RES" terminal (default function is fault reset)	0 - 54	-	6	9-8 5-1
"ST" INPUT TERMINAL FUNCTION	51*	assign function to "ST" terminal (default function is drive enable)	0 - 54	-	7	9-8 5-1
"S5" INPUT TERMINAL FUNCTION	52*	assign function to "S5" terminal (available on option board)	0 - 54	-	8	9-8
"S6" INPUT TERMINAL FUNCTION	53*	assign function to "S6" terminal (available on option board)	0 - 54	-	9	9-8
"S7" INPUT TERMINAL FUNCTION	54*	assign function to "S7" terminal (available on option board)	0 - 54	-	10	9-8
POTENTIAL TERMINAL FUNCTION	55*	pick function that is always active (no physical connection)	0 - 42	-	33	9-8
R, S1-S7 TERMINAL RESPONSE TIME	56	"R" and "S1"- "S7" terminals' response time	1 - 100	1	6	9-10 5-1
"F" INPUT TERMINAL RESPONSE TIME	57	"F" terminal response time selection	1 - 100	1	6	9-10 5-1
"RES" INPUT TERMINAL RESPONSE TIME	58	"RES" terminal response time selection	1 - 100	1	6	9-10 5-1
"ST" INPUT TERMINAL RESPONSE TIME	59	"ST" terminal response time selection	1 - 100	1	6	9-10 5-1
"RCH" CONTACTS FUNCTION	60	assign function to "RCH" output contact	0 - 63	1	6	9-10 5-1
"RCH" CONTACTS DELAY TIME	61	"RCH" output contact delay time	1 - 100	1	1	9-10 5-1
"RCH" CONTACTS HOLD TIME	62	"RCH" output contact hold time	1 - 100	1	1	9-10 5-1

*Table continued on next page*

\*Items 44 - 55 are available only when Item 43 Adjustment Range option 1 is selected.

# TOSHIBA

## GROUP: TERMINAL SELECTION PARAMETERS (cont'd)

LIQUID CRYSTAL DISPLAY	ITEM NO.	PARAMETER DESCRIPTION	ADJUSTMENT RANGE	DISPLAY RESOLUTION	FACTORY SETTING	PAGE NO.
"LOW" CONTACTS FUNCTION	63	assign function to "LOW" contact	0 - 63	1	4	9-10 5-1
"LOW" CONTACTS DELAY TIME	64	"LOW" output contact delay time	1 - 100	1	1	9-10 5-1
"LOW" CONTACTS HOLD TIME	65	"LOW" output contact hold time	1 - 100	1	1	9-10 5-1
"FL" CONTACTS FUNCTION	66	assign function to "FL" output contact	0 - 63	1	10	9-10 5-1
"FL" CONTACTS DELAY TIME	67	"FL" output contacts delay time	1 - 100	1	1	9-10 5-1
"FL" CONTACTS HOLD TIME	68	"FL" output contacts hold time	1 - 100	1	1	9-10 5-1
"OUT" CONTACTS FUNCTION	69	assign function to "OUT" output contacts (available on option board)	0 - 61	1	8	9-10
"OUT" CONTACTS DELAY TIME	70	"OUT" output contact delay time (available on option board)	1 - 100	1	1	9-10
"OUT" CONTACTS HOLD TIME	71	"OUT" output contact hold time (available on option board)	1 - 100	1	1	9-10
LOW SPEED SIGNAL OUTPUT FREQ	72	Low-speed signal frequency	0 - Max. Output Freq.	0.1/0.01 Hz	0.0	9-13
ACC/DEC COMPLETE DETECT BAND	73	Acc/Dec complete detection bandwidth	0 - Max. Output Freq.	0.1/0.01 Hz	2.5	9-13
SPEED REACH MAXIMUM FREQUENCY	74	Speed reach high frequency	0 - Max. Output Freq.	0.1/0.01 Hz	0.0	9-13
SPEED REACH MINIMUM FREQUENCY	75	Speed reach low frequency	0 - Max. Output Freq.	0.1/0.01 Hz	0.0	9-13
COMMERCIAL POWER/INV SWITCHING OUTPUT	76	Bypass control	0: Off 1: Automatic switching upon trip 2: Switching upon receipt of switching signal * 3: Both 1 and 2 above*	-	0	9-13
COMMERCIAL POWER/INV SWITCH FREQ	77*	Incoming power/inverter switching frequency	0 - Max Output Freq	0.1/0.01 Hz	60.0 Hz	9-13

*Table continued on next page*

\*Item 77 is available only when Item 76 Adjustment Range option 2 or 3 is selected.



**GROUP: TERMINAL SELECTION PARAMETERS (cont'd)**

LIQUID CRYSTAL DISPLAY	ITEM NO.	PARAMETER DESCRIPTION	ADJUSTMENT RANGE	FACTORY SETTING	PAGE NO.
"FP" OUTPUT TERMINAL PULSE FREQUENCY	78	Output terminal pulse frequency selection	0: 48 times output frequency 1: 96 times output frequency 2: 360 times output frequency	0	9-13 5-1
RR INPUT SPECIAL FUNCTION SELECT	79	RR input special function selection	0: Standard 1: Set effective Maximum Output Frequency 2: Scale ACC/DEC times 3: Set effective Voltage Boost 4: Set effective Stall Level	0	9-13 5-1

## GROUP: FREQUENCY SETTING PARAMETERS

LIQUID CRYSTAL DISPLAY	ITEM NO.	PARAMETER DESCRIPTION	ADJUSTMENT RANGE	DISPLAY RESOLUTION	FACTORY SETTING	PAGE NO.
FREQUENCY PRIORITY SELECTION #1	80	Assign priority to frequency reference sources	1:RR terminal 2:IV terminal 3:RX terminal 4:PG input 5:Binary input or MOP	-	1	9-13
FREQUENCY PRIORITY SELECTION #2	81	Assign second priority frequency reference source	1:RR terminal 2:IV terminal 3:RX terminal 4:PG input 5:Binary input or MOP		2	9-13
ANALOG INPUT FILTER	82	Analog input filter	0 - 3	-	0	9-14
RR TERMINAL STANDARD OR ADJUSTABLE	83	RR input selection	0: Standard 1: Adjustable *	-	0	9-14 5-1
RR REFERENCE SETTING POINT #1	84*	RR reference point #1	0 - 100% of terminal max (10V)	1%	0	9-14
RR REF POINT #1 FREQUENCY	85*	Output frequency desired with input entered in Item 84	0 - Max. Out. Freq.	0.1/0.01 Hz	0.0	9-14
RR REFERENCE SETTING POINT #2	86*	RR reference point #2	0 - 100% of terminal max (10V)	1%	100	9-14
RR REF POINT #2 FREQUENCY	87*	Output frequency desired with input entered in Item 86	0 - Max.Out. Freq.	0.1/0.01 Hz	80.0	9-14
IV TERMINAL STANDARD OR ADJUSTABLE	88	IV input selection	0: Standard 1: Adjustable **	-	0	9-14 5-1
IV REFERENCE SETTING POINT #1	89**	IV reference point #1	0 - 100% of terminal maximum	1%	20	9-14
IV REF POINT #1 FREQUENCY	90**	Output frequency desired with input entered in Item 89	0 - Max. Out. Freq.	0.1/0.01 Hz	0.0	9-14
IV REFERENCE SETTING POINT #2	91**	IV reference point #2	0 - 100% of terminal maximum	1%	100	9-14
IV REF POINT #2 FREQUENCY	92**	Output frequency desired with input entered in Item 91	0 - Max. Out. Freq.	0.1/0.01 Hz	80.0	9-14
RX TERMINAL STANDARD OR ADJUSTABLE	93	RX input selection	0: Standard 1: Adjustable ***	-	0	9-14 5-1
RX REFERENCE SETTING POINT #1	94***	RX reference point #1	-100 - 100% of terminal maximum	1%	0	9-14
RX REF POINT #1 FREQUENCY	95***	Output Hz desired with input entered in Item 94	-Max. Out. Freq. to Max. Out. Freq.	0.1/0.01 Hz	0.0	9-14
RX REFERENCE SETTING POINT #2	96***	RX reference point #2	-100 - 100% of terminal maximum	1%	100	9-14
RX REF POINT #2 FREQUENCY	97***	Output Hz desired with input entered in Item 96	-Max. Out. Freq. to Max. Out. Freq.	0.1/0.01 Hz	80.0	9-14

*Table continued on next page*

\*Items 84 - 87 are available only when Item 83 Adjustment Range option 1 is selected.

\*\*Items 89 - 92 are available only when Item 88 Adjustment Range option 1 is selected.

\*\*\*Items 94 - 97 are available only when Item 93 Adjustment Range option 1 is selected.

## GROUP: FREQUENCY SETTING PARAMETERS (cont'd)

LIQUID CRYSTAL DISPLAY	ITEM NO.	PARAMETER DESCRIPTION	ADJUSTMENT RANGE	DISPLAY RESOLUTION	FACTORY SETTING	PAGE NO.
PG TERMINAL STANDARD OR ADJUSTABLE	98	Bias/gain for PG input selection (option board)	0: Standard 1: Adjustable*	-	0	9-14
PG REFERENCE SETTING POINT #1	99*	PG reference point #1	-100 - 100% of Max. Out. Freq. X PPR	1%	0	9-14
PG REF POINT #1 FREQUENCY	100*	Output Hz desired when reference equals value entered in Item 99	-Max. Out. Freq. to Max. Out. Freq.	0.1/0.01 Hz	0.0	9-14
PG REFERENCE SETTING POINT #2	101*	PG reference point #2	-100 - 100% of Max. Out. Freq. X PPR	1%	100	9-14
PG REF POINT #2 FREQUENCY	102*	Output Hz desired when reference equals value entered in Item 101	-Max. Out. Freq. to Max. Out. Freq.	0.1/0.01 Hz	80.0	9-14
BINARY INPUT STD OR ADJUSTABLE	103	Bias/gain for binary input (via input terminals).	0: Standard 1: Adjustable**	-	0	9-14
BINARY REF SETTING POINT #1	104**	Binary reference point #1	0 - 100 %	1%	0	9-14
BINARY REF POINT #1 FREQUENCY	105**	Output Hz desired when reference equals value entered in Item 104	-Max. Out. Freq. to Max. Out. Freq.	0.1/0.01 Hz	0.0	9-14
BINARY REF SETTING POINT #2	106**	Binary reference point #2	0 - 100 %	1%	100	9-14
BINARY REF POINT #2 FREQUENCY	107**	Output Hz desired when reference equals value entered in Item 106	-Max. Out. Freq. to Max. Out. Freq.	0.1/0.01 Hz	80.0	9-14
JOG RUN FREQUENCY	108	Jog run frequency	0.0 - 20***	0.1/0.01 Hz	0.0	9-15
JOG STOP METHOD	109***	Jog stop control	0: Decelerated stop 1: Coast to stop 2: DC injection braking	-	0	9-15

*Table continued on next page*

\*Items 99 - 102 are available only when Item 98 Adjustment Range option 1 is selected.

\*\*Items 104 - 107 are available only when Item 103 Adjustment Range option 1 is selected.

\*\*\*Item 109 is available only when Item 108 Adjustment Range is set to other than "0".

**GROUP: FREQUENCY SETTING PARAMETERS (cont'd)**

LIQUID CRYSTAL DISPLAY	ITEM NO.	PARAMETER DESCRIPTION	ADJUSTMENT RANGE	DISPLAY RESOLUTION	FACTORY SETTING	PAGE NO.
PRESET SPEED SELECTION	110	Selects number of preset speeds to be unblinded	0: Disabled 1: 1st speed only * 2: speeds 1 thru 2 * 3: speeds 1 thru 3* 4: speeds 1 thru 4* 5: speeds 1 thru 5* 6: speeds 1 thru 6* 7: speeds 1 thru 7* 8: speeds 1 thru 8* 9: speeds 1 thru 9* 10:speeds 1 thru 10* 11:speeds 1 thru 11* 12:speeds 1 thru 12* 13:speeds 1 thru 13* 14:speeds 1 thru 14* 15:speeds 1 thru 15*	-	0	9-15
PRESET SPEED MODE ACTIVATION	111*	Mode selection	0: Deactivated 1: Activated	-	0	9-15
PRESET SPEED #1 FREQUENCY	112*	1st speed	Lower limit frequency to upper limit frequency	0.1/0.01 Hz	0.0	9-15
PRESET SPEED #1 OPERATING MODE	113*	1st speed run mode	0: Acc/dec 1, V/F 1, forward run 1: Acc/dec 1, V/F 1, reverse run 2: Acc/dec 2, V/F 1, forward run 3: Acc/dec 2, V/F 1, reverse run 4: Acc/dec 1, V/F 2, forward run 5: Acc/dec 1, V/F 2, reverse run 6: Acc/dec 2, V/F 2, forward run 7: Acc/dec 2, V/F 2, reverse run		0	9-15
PRESET SPEED #2 FREQUENCY	114*	2nd speed	Lower limit frequency to upper limit frequency	0.1/0.01 Hz	0.0	9-15
PRESET SPEED #2 OPERATING MODE	115*	2nd speed run mode	<i>Same options as Item 113</i>	-	0	9-15
PRESET SPEED #3 FREQUENCY	116*	3rd speed	Lower limit frequency to upper limit frequency	0.1/0.01 Hz	0.0	9-15
PRESET SPEED #3 OPERATING MODE	117*	3rd speed run mode	<i>Same options as Item 113</i>	-	0	9-15

*Table continued on next page*

\*Items 111 - 117 are available only when Item 110 Adjustment Range options 1 - 15 are selected.

**GROUP: FREQUENCY SETTING PARAMETERS (cont'd)**

LIQUID CRYSTAL DISPLAY	ITEM NO.	PARAMETER DESCRIPTION	ADJUSTMENT RANGE	DISPLAY RESOLUTION	FACTORY SETTING	PAGE NO.
PRESET SPEED #4 FREQUENCY	118*	4th speed	Lower limit frequency to upper limit frequency	0.1/0.01 Hz	0.0	9-15
PRESET SPEED #4 OPERATING MODE	119*	4th speed run mode	<i>Same options as Item 113</i>	-	0	9-15
PRESET SPEED #5 FREQUENCY	120*	5th speed	Lower limit frequency to upper limit frequency	0.1/0.01 Hz	0.0	9-15
PRESET SPEED #5 OPERATING MODE	121*	5th speed run mode	<i>Same options as Item 113</i>	-	0	9-15
PRESET SPEED #6 FREQUENCY	122*	6th speed	Lower limit frequency to upper limit frequency	0.1/0.01 Hz	0.0	9-15
PRESET SPEED #6 OPERATING MODE	123*	6th speed run mode	<i>Same options as Item 113</i>	-	0	9-15
PRESET SPEED #7 FREQUENCY	124*	7th speed	Lower limit frequency to upper limit frequency	0.1/0.01 Hz	0.0	9-15
PRESET SPEED #7 OPERATING MODE	125*	7th speed run mode	<i>Same options as Item 113</i>	-	0	9-15
PRESET SPEED #8 FREQUENCY	126*	8th speed	Lower limit frequency to upper limit frequency	0.1/0.01 Hz	0.0	9-15
PRESET SPEED #8 OPERATING MODE	127*	8th speed run mode	<i>Same options as Item 113</i>	-	0	9-15
PRESET SPEED #9 FREQUENCY	128*	9th speed	Lower limit frequency to upper limit frequency	0.1/0.01 Hz	0.0	9-15
PRESET SPEED #9 OPERATING MODE	129*	9th speed run mode	<i>Same options as Item 113</i>	-	0	9-15
PRESET SPEED #10 FREQUENCY	130*	10th speed	Lower limit frequency to upper limit frequency	0.1/0.01 Hz	0.0	9-15
PRESET SPEED #10 OPERATING MODE	131*	10th speed run mode	<i>Same options as Item 113</i>	-	0	9-15
PRESET SPEED #11 FREQUENCY	132*	11th speed	Lower limit frequency to upper limit frequency	0.1/0.01 Hz	0.0	9-15
PRESET SPEED #11 OPERATING MODE	133*	11th speed run mode	<i>Same options as Item 113</i>	-	0	9-15

*Table continued on next page*

\*Items 118 - 133 are available only when Item 110 Adjustment Range options 1 - 15 are selected.

**GROUP: FREQUENCY SETTING PARAMETERS (cont'd)**

LIQUID CRYSTAL DISPLAY	ITEM NO.	PARAMETER DESCRIPTION	ADJUSTMENT RANGE	DISPLAY RESOLUTION	FACTORY SETTING	PAGE NO.
PRESET SPEED #12 FREQUENCY	134*	12th speed	Lower limit frequency to upper limit frequency	0.1/0.01 Hz	0.0	9-15
PRESET SPEED #12 OPERATING MODE	135*	12th speed run mode	<i>Same options as Item 113</i>	-	0	9-15
PRESET SPEED #13 FREQUENCY	136*	13th speed	Lower limit frequency to upper limit frequency	0.1/0.01 Hz	0.0	9-15
PRESET SPEED #13 OPERATING MODE	137*	13th speed run mode	<i>Same options as Item 113</i>	-	0	9-15
PRESET SPEED #14 FREQUENCY	138*	14th speed	Lower limit frequency to upper limit frequency	0.1/0.01 Hz	0.0	9-15
PRESET SPEED #14 OPERATING MODE	139*	14th speed run mode	<i>Same options as Item 113</i>	-	0	9-15
PRESET SPEED #15 FREQUENCY	140*	15th speed	Lower limit frequency to upper limit frequency	0.1/0.01 Hz	0.0	9-15
PRESET SPEED #15 OPERATING MODE	141*	15th speed run mode	<i>Same options as Item 113</i>	-	0	9-15

\*Items 134 - 141 are available only when Item 110 Adjustment Range options 1 - 15 are selected.

**GROUP : PROTECTION PARAMETERS**

LIQUID CRYSTAL DISPLAY	ITEM NO.	PARAMETER DESCRIPTION	ADJUSTMENT RANGE	DISPLAY RESOLUTION	FACTORY SETTING	PAGE NO.
DYNAMIC BRAKING SELECTION	142	Dynamic braking selection	0: No DBR used 1: DBR used. Drive's DBR OL protect off. 2: DBR used. Drive's DBR OL protect on.	-	0	9-15
BRAKING RESISTOR VALUE	143*	DBR resistor value	1.0 - 1000	0.1 ohm	*****	9-15
BRAKING RESISTOR POWER RATING	144*	DBR capacity	0.01 - 600	0.01 kW	*****	9-15
OVERVOLTAGE STALL PROTECTION	145	Overvoltage stall protection	0: On 1: Off	-	0	9-16
DC INJECTION START FREQUENCY	146	DC injection starting frequency	0 - 120 **	0.1/0.01 Hz	0.0	9-17
DC INJECTION CURRENT MAGNITUDE	147**	DC injection current	0 - 100% or amps	1 %/A	0	9-17
DC INJECTION TIME	148**	DC injection time	0 - 10	0.1 sec	0.0	9-17
FWD/REV DC INJECTION PRIORITY CTRL	149	DC injection during direction change	0: Off 1: On	-	0	9-17
MOTOR SHAFT STATIONARY CTRL	150	continuous DC trickle	0: Off 1: On	-	0	9-17
EMERGENCY OFF MODE SELECTION	151	Emergency stop selection	0: Coast to stop 1: Decelerated stop 2: DC injection stop ***	-	0	9-17
EMERGENCY OFF DC INJECTION TIME	152***	Emergency stop DC injection time	0 - 10	0.1 sec	0.1	9-17
NUMBER OF RETRY ATTEMPTS	153	Retry selection	0: No retry 1: Retry 1 time **** 2: Retry 2 times **** 3: Retry 3 times **** 4: Retry 4 times **** 5: Retry 5 times **** 6: Retry 6 times **** 7: Retry 7 times **** 8: Retry 8 times **** 9: Retry 9 times **** 10: Retry 10 times ****	-	0	9-17
TIME BETWEEN RETRY ATTEMPTS	154 ****	Retry time setting	0.0 - 10	0.1 sec	1.0	9-17

*Table continued on next page*

\*Items 143 - 144 are available only when Item 142 Adjustment Range option 2 is selected.

\*\* Items 147 - 148 are available only when Item 146 Adjustment Range is set to other than "0".

\*\*\* Item 152 is available only when Item 151 Adjustment Range option 2 is selected.

\*\*\*\* Item 154 is available only when Item 153 Adjustment Range options 1 - 10 are selected.

\*\*\*\*\* Default wattage and ohm values depend on the inverter size.

## GROUP : PROTECTION PARAMETERS (cont'd)

LIQUID CRYSTAL DISPLAY	ITEM NO.	PARAMETER DESCRIPTION	ADJUSTMENT RANGE	DISPLAY RESOLUTION	FACTORY SETTING	PAGE NO.
REGENERATION POWER RIDE-THROUGH	155	allows drive to use regen for control power	0: Off 1: On *	-	0	9-17
REGENERATION RIDE-THROUGH TIME	156*	maximum allowable ride-through time	0.0 - 25	0.1 sec	2.0	9-17
AUTO-RESTART (MOTOR SPEED SEARCH)	157	"catch" a spinning motor (forward or reverse)	0: Off 1: After momentary power failure (ride-through) 2: After "ST" is shorted to "CC" 3: Both 1 and 2	-	0	9-17
ELECTRONIC THERMAL PROTECT LVL 1	158	sets drive's overload to protect motor	10-100% or amps	1%/A	100	9-18
OVERLOAD REDUCTION START FREQ	159	frequency at which drive's motor overload becomes speed sensitive	0 - 30	0.1/0.01 Hz	30.0	9-18
MOTOR 150% OVERLOAD TIME LIMIT	160	sets motor overload time	10 - 2400	10 sec	600	9-18
OVERLOAD SELECTION	161	OL selection	0: Standard 1: Soft stall on 2: Motor OL trip off 3: Soft stall on, Motor OL trip off	-	0	9-18
STALL PROTECTION ENABLE	162	Stall protection #1	0: On ** 1: Off	-	0	9-18
STALL PROTECTION CURRENT LEVEL	163**	sets current limit	10 - 215%/A	1 %/A	150	9-18
UNDERVOLTAGE TRIP SELECTION	164	Undervoltage detection can cause a warning or a trip	0: Trip disabled 1: Trip enabled	-	0	9-18
UNDERVOLTAGE DETECT TIME	165	Undervoltage detection time	0 - 10	0.01 sec	0.03	9-18
LOW CURRENT DETECT SELECTION	166	Low current detection can cause a warning or a trip	0: Trip disabled 1: Trip enabled	-	0	9-18
LOW CURRENT DETECT LEVEL	167	Low current detection level	0 - 100% or amps	1%/A	0	9-19
LOW CURRENT DETECTION TIME	168	Low current detection time	0 - 255	1 sec	0	9-19
OUTPUT SHORT-CIRCUIT DETECTION SELECT	169	Output short-circuit detection selection (OCL)	0: Standard 1: Less sensitive short-circuit checki 2: Short-circuit check at power up only 3: Combination of 1 and 2 above	-	0	9-19

*Table continued on next page*

\*Item 156 is available only when Item 155 Adjustment Range option 1 is selected.

\*\*Item 163 is available only when Item 162 Adjustment Range option 0 is selected.



**GROUP: PROTECTION PARAMETERS (cont'd)**

LIQUID CRYSTAL DISPLAY	ITEM NO.	PARAMETER DESCRIPTION	ADJUSTMENT RANGE	DISPLAY RESOLUTION	FACTORY SETTING	PAGE NO.
OVERTORQUE TRIP SELECTION	170	Overtorque detection can cause a warning or a trip	0: Trip disabled 1: Trip enabled	-	0	9-19
OVERTORQUE TRIP LEVEL	171	Overtorque trip level	10-200% or amps	1%/A	2.0	9-19
FAULT TRIP EEPROM SAVE ENABLE	172	Fault trip saving	0: Fault cleared when power cycled 1: Fault display retained when power cycled*	-	0	9-19
COOLING FAN CONTROL SELECTION	173	Cooling fan control selection	0: Automatic fan 1: Fan always on	-	0	9-19
CUMULATIVE RUN TIMER ALARM SETTING	174	Cumulative run timer alarm setting	0.00 - 999.9 (.01 = 1 hour)	0.02	175.0	9-19

\*This parameter disables the retry function (see Items 153 and 154).

**GROUP: PATTERN RUN CONTROL PARAMETERS**

LIQUID CRYSTAL DISPLAY	ITEM NO.	PARAMETER DESCRIPTION	ADJUSTMENT RANGE	DISPLAY RESOLUTION	FACTORY SETTING	PAGE NO.
PATTERN RUN SELECTION	175	Pattern run on/off	0: Off 1: On *	-	0	9-19
PATTERN RUN CONTINUE MODE	176*	Pattern run mode	0: Pattern is reset when inverter is stopped 1: Pattern resumes with speed of interruption and with time left at interruption	-	0	9-19
PATTERN GROUP #1 SPEED #0	177*	1st Pattern Group 1st speed selection	0: Skip 1: Preset speed #1 2: Preset speed #2 3: Preset speed #3 4: Preset speed #4 5: Preset speed #5 6: Preset speed #6 7: Preset speed #7 8: Preset speed #8 9: Preset speed #9 10:Preset speed #10 11:Preset speed #11 12:Preset speed #12 13:Preset speed #13 14:Preset speed #14 15:Preset speed #15	-	1	9-20
PATTERN GROUP #1 SPEED #1	178*	1st Pattern Group 2nd speed selection	<i>Same options as Item 177</i>	-	2	9-20
PATTERN GROUP #1 SPEED #2	179*	1st Pattern Group 3rd speed selection	<i>Same options as Item 177</i>	-	3	9-20
PATTERN GROUP #1 SPEED #3	180*	1st Pattern Group 4th speed selection	<i>Same options as Item 177</i>	-	4	9-20
PATTERN GROUP #1 SPEED #4	181*	1st Pattern Group 5th speed selection	<i>Same options as Item 177</i>	-	5	9-20
PATTERN GROUP #1 SPEED #5	182*	1st Pattern Group 6th speed selection	<i>Same options as Item 177</i>	-	6	9-20
PATTERN GROUP #1 SPEED #6	183*	1st Pattern Group 7th speed selection	<i>Same options as Item 177</i>	-	7	9-20
PATTERN GROUP #1 SPEED #7	184*	1st Pattern Group 8th speed selection	<i>Same options as Item 177</i>	-	8	9-20

*Table continued on next page*

\*Items 176 - 184 are available only when Item 175 Adjustment Range option 1 is selected.

**GROUP : PATTERN RUN CONTROL PARAMETERS (cont'd)**

LIQUID CRYSTAL DISPLAY	ITEM NO.	PARAMETER DESCRIPTION	ADJUSTMENT RANGE	DISPLAY RESOLUTION	FACTORY SETTING	PAGE NO.
PATTERN GROUP #1 NUMBER OF CYCLES	185*	number of repeats for entire pattern group	1 - 254, 255=infinity	-	1	9-20
PATTERN GROUP #2 SPEED #0	186*	2nd Pattern Group 1st speed selection	<i>Same options as Item 177</i>	-	9	9-20
PATTERN GROUP #2 SPEED #1	187*	2nd Pattern Group 2nd speed selection	<i>Same options as Item 177</i>	-	10	9-20
PATTERN GROUP #2 SPEED #2	188*	2nd Pattern Group 3rd speed selection	<i>Same options as Item 177</i>	-	11	9-20
PATTERN GROUP #2 SPEED #3	189*	2nd Pattern Group 4th speed selection	<i>Same options as Item 177</i>	-	12	9-20
PATTERN GROUP #2 SPEED #4	190*	2nd Pattern Group 5th speed selection	<i>Same options as Item 177</i>	-	13	9-20
PATTERN GROUP #2 SPEED #5	191*	2nd Pattern Group 6th speed selection	<i>Same options as Item 177</i>	-	14	9-20
PATTERN GROUP #2 SPEED #6	192*	2nd Pattern Group 7th speed selection	<i>Same options as Item 177</i>	-	15	9-20
PATTERN GROUP #2 SPEED #7	193*	2nd Pattern Group 8th speed selection	<i>Same options as Item 177</i>	-	0	9-20
PATTERN GROUP #2 NUMBER OF CYCLES	194*	number of repeats of entire pattern group	1 - 254, 255=infinity	-	1	9-20
PATTERN GROUP #3 SPEED #0	195*	3rd Pattern Group 1st speed selection	<i>Same options as Item 177</i>	-	1	9-20
PATTERN GROUP #3 SPEED #1	196*	3rd Pattern Group 2nd speed selection	<i>Same options as Item 177</i>	-	1	9-20
PATTERN GROUP #3 SPEED #2	197*	3rd Pattern Group 3rd speed selection	<i>Same options as Item 177</i>	-	2	9-20
PATTERN GROUP #4 SPEED #3	198*	3rd Pattern Group 4th speed selection	<i>Same options as Item 177</i>	-	3	9-20

*Table continued on next page*

\*Items 185 - 198 are available only when Item 175 Adjustment Range option 1 is selected.

**GROUP : PATTERN RUN CONTROL PARAMETERS (cont'd)**

LIQUID CRYSTAL DISPLAY	ITEM NO.	PARAMETER DESCRIPTION	ADJUSTMENT RANGE	DISPLAY RESOLUTION	FACTORY SETTING	PAGE NO.
PATTERN GROUP #3 SPEED #4	199*	3rd Pattern Group 5th speed selection	<i>Same options as Item 177</i>	-	4	9-20
PATTERN GROUP #3 SPEED #5	200*	3rd Pattern Group 6th speed selection	<i>Same options as Item 177</i>	-	5	9-20
PATTERN GROUP #3 SPEED #6	201*	3rd Pattern Group 7th speed selection	<i>Same options as Item 177</i>	-	6	9-20
PATTERN GROUP #3 SPEED #7	202*	3rd Pattern Group 8th speed selection	<i>Same options as Item 177</i>	-	7	9-20
PATTERN GROUP #3 NUMBER OF CYCLES	203*	number of repeats of entire pattern group	1 - 254, 255=infinity	-	1	9-20
PATTERN GROUP #4 SPEED #0	204*	4th Pattern Group 1st speed selection	<i>Same options as Item 177</i>	-	9	9-20
PATTERN GROUP #4 SPEED #1	205*	4th Pattern Group 2nd speed selection	<i>Same options as Item 177</i>	-	10	9-20
PATTERN GROUP #4 SPEED #2	206*	4th Pattern Group 3rd speed selection	<i>Same options as Item 177</i>	-	11	9-20
PATTERN GROUP #4 SPEED #3	207*	4th Pattern Group 4th speed selection	<i>Same options as Item 177</i>	-	12	9-20
PATTERN GROUP #4 SPEED #4	208*	4th Pattern Group 5th speed selection	<i>Same options as Item 177</i>	-	13	9-20
PATTERN GROUP #4 SPEED #5	209*	4th Pattern Group 6th speed selection	<i>Same options as Item 177</i>	-	14	9-20
PATTERN GROUP #4 SPEED #6	210*	4th Pattern Group 7th speed selection	<i>Same options as Item 177</i>	-	15	9-20
PATTERN GROUP #4 SPEED #7	211*	4th Pattern Group 8th speed selection	<i>Same options as Item 177</i>	-	0	9-20
PATTERN GROUP #4 NUMBER OF CYCLES	212*	number of repeats of entire pattern group	1 - 254, 255=infinity	-	1	9-20

*Table continued on next page*

\*Items 199 - 212 are available only when Item 175 Adjustment Range option 1 is selected.

**GROUP : PATTERN RUN CONTROL PARAMETERS (cont'd)**

LIQUID CRYSTAL DISPLAY	ITEM NO.	PARAMETER DESCRIPTION	ADJUSTMENT RANGE	DISPLAY RESOLUTION	FACTORY SETTING	PAGE NO.
SPEED #1 CONTINUE MODE	213	determines how speed time is measured	0: Count in seconds from time of activation * 1: Count in minutes from time of activation * 2: Count in seconds from time set speed is reached * 3: Count in minutes. from time set speed is reached * 4: Non-stop (continue until STOP command) 5: Continue until next step command		0	9-20
SPEED #1 DRIVE TIME	214*	Speed #1 drive time	0 - 8000	1 sec./min.	0	9-21
SPEED #2 CONTINUE MODE	215	Speed #2 drive continuation mode	Same options as Item 213		0	9-20
SPEED #2 DRIVE TIME	216**	Speed #2 drive time	0 - 8000	1 sec./min.	0	9-21
SPEED #3 CONTINUE MODE	217	Speed #3 drive continuation mode	Same options as Item 213		0	9-20
SPEED #3 DRIVE TIME	218***	Speed #3 drive time	0 - 8000	1 sec./min.	0	9-21
SPEED #4 CONTINUE MODE	219	Speed #4 drive continuation mode	Same options as Item 213		0	9-20
SPEED #4 DRIVE TIME	220****	Speed #4 drive time	0 - 8000	1 sec./min.	0	9-21
SPEED #5 CONTINUE MODE	221	Speed #5 drive continuation mode	Same options as Item 213		0	9-20
SPEED #5 DRIVE TIME	222*****	Speed #5 drive time	0 - 8000	1 sec./min.	0	9-21

*Table continued on next page*

\*Item 214 is available only when Item 213 Adjustment Range option 0 - 3 is selected.

\*\*Item 216 is available only when Item 215 Adjustment Range option 0 - 3 is selected.

\*\*\*Item 218 is available only when Item 217 Adjustment Range option 0 - 3 is selected.

\*\*\*\*Item 220 is available only when Item 219 Adjustment Range option 0 - 3 is selected.

\*\*\*\*\*Item 222 is available only when Item 221 Adjustment Range option 0 - 3 is selected.

## GROUP : PATTERN RUN CONTROL PARAMETERS (cont'd)

LIQUID CRYSTAL DISPLAY	ITEM NO.	PARAMETER DESCRIPTION	ADJUSTMENT RANGE	DISPLAY RESOLUTION	FACTORY SETTING	PAGE NO.
SPEED #6 CONTINUE MODE	223	Speed #6 drive continuation mode	<i>Same options as Item 213</i>	-	0	9-20
SPEED #6 DRIVE TIME	224*	Speed #6 drive time	0 - 8000	1 sec./min.	0	9-21
SPEED #7 CONTINUE MODE	225	Speed #7 drive continuation mode	<i>Same options as Item 213</i>	-	0	9-20
SPEED #7 DRIVE TIME	226**	Speed #7 drive time	0 - 8000	1 sec./min.	0	9-21
SPEED #8 CONTINUE MODE	227	Speed #8 drive continuation mode	<i>Same options as Item 213</i>	-	0	9-20
SPEED #8 DRIVE TIME	228***	Speed #8 drive time	0 - 8000	1 sec./min.	0	9-21
SPEED #9 CONTINUE MODE	229	Speed #9 drive continuation mode	<i>Same options as Item 213</i>	-	0	9-20
SPEED #9 DRIVE TIME	230****	Speed #9 drive time	0 - 8000	1 sec./min.	0	9-21
SPEED #10 CONTINUE MODE	231	Speed #10 drive continuation mode	<i>Same options as Item 213</i>	-	0	9-20
SPEED #10 DRIVE TIME	232*****	Speed #10 drive time	0 - 8000	1 sec./min.	0	9-21

*Table continued on next page*

\*Item 224 is available only when Item 223 Adjustment Range option 0 - 3 is selected.

\*\*Item 226 is available only when Item 225 Adjustment Range option 0 - 3 is selected.

\*\*\*Item 228 is available only when Item 227 Adjustment Range option 0 - 3 is selected.

\*\*\*\*Item 230 is available only when Item 229 Adjustment Range option 0 - 3 is selected.

\*\*\*\*\*Item 232 is available only when Item 231 Adjustment Range option 0 - 3 is selected.

**GROUP : PATTERN RUN CONTROL PARAMETERS (cont'd)**

LIQUID CRYSTAL DISPLAY	ITEM NO.	PARAMETER DESCRIPTION	ADJUSTMENT RANGE	DISPLAY RESOLUTION	FACTORY SETTING	PAGE NO.
SPEED #11 CONTINUE MODE	233	Speed #11 drive continuation mode	<i>Same options as Item 213</i>	-	0	9-20
SPEED #11 DRIVE TIME	234*	Speed #11 drive time	0 - 8000	1 sec./min.	0	9-21
SPEED #12 CONTINUE MODE	235	Speed #12 drive continuation mode	<i>Same options as Item 213</i>	-	0	9-20
SPEED #12 DRIVE TIME	236**	Speed #12 drive time	0 - 8000	1 sec./min.	0	9-21
SPEED #13 CONTINUE MODE	237	Speed #13 drive continuation mode	<i>Same options as Item 213</i>	-	0	9-20
SPEED #13 DRIVE TIME	238***	Speed #13 drive time	0 - 8000	1 sec./min.	0	9-21
SPEED #14 CONTINUE MODE	239	Speed #14 drive continuation mode	<i>Same options as Item 213</i>	-	0	9-20
SPEED #14 DRIVE TIME	240****	Speed #14 drive time	0 - 8000	1 sec./min.	0	9-21
SPEED #15 CONTINUE MODE	241	Speed #15 drive continuation mode	<i>Same options as Item 213</i>	-	0	9-20
SPEED #15 DRIVE TIME	242*****	Speed #15 drive time	0 - 8000	1 sec./min.	0	9-21

*Table continued on next page*

\*Item 234 is available only when Item 233 Adjustment Range option 0 - 3 is selected.

\*\*Item 236 is available only when Item 235 Adjustment Range option 0 - 3 is selected.

\*\*\*Item 238 is available only when Item 237 Adjustment Range option 0 - 3 is selected.

\*\*\*\*Item 240 is available only when Item 239 Adjustment Range option 0 - 3 is selected.

\*\*\*\*\*Item 242 is available only when Item 241 Adjustment Range option 0 - 3 is selected.

## GROUP : FEEDBACK PARAMETERS

LIQUID CRYSTAL DISPLAY	ITEM NO.	PARAMETER DESCRIPTION	ADJUSTMENT RANGE	DISPLAY RESOLUTION	FACTORY SETTING	PAGE NO.
FEEDBACK CONTROL SELECTION	243	select type of feedback control	0: No feedback control 1: PID setpoint control * 2: Speed feedback control *	-	0	9-21
FEEDBACK INPUT SIGNAL SELECTION	244*	Feedback input signal selection	1: "RR" terminal 2: "IV" terminal 3: "RX" terminal 4: PG feedback (option board) 5: RS232C input 6: RS485 board or 12-bit binary/BCD option board input 7: Binary input	-	2	9-21
PROPORTIONAL GAIN	245*	Proportional gain	0.01 - 2.55	0.01	0.30	9-21
INTEGRAL GAIN	246*	Integral time	0.01 - 360.0	0.01 sec	5.00	9-21
ANTI-HUNTING GAIN	247*	Differential time	0.0 - 25.5	0.1 sec	0.0	9-21
LAG TIME CONSTANT	248*	Lag time constant	0 - 255	1	80	9-21
PID LOWER LIMIT FREQUENCY	249**	unique lower limit for PID	0.0 - Max Out Freq	0.1/0.01 Hz	0.0	9-21
PID DEVIATION LIMIT SELECTION	250	PID deviation limit selection	0: No PID deviation limit 1: PID deviation limited***	-	0	9-21
PID DEVIATION UPPER LIMIT	251***	PID deviation upper limit	0 - 50%	1%	50	9-21
PID DEVIATION LOWER LIMIT	252***	PID deviation lower limit	0 - 50%	1%	50	9-21
PG INPUT: NUMBER OF PULSES	253	pulses per rev (for feedback) or # pulses = 1Hz for pulse reference	1 - 9999	1	500	9-21
PG INPUT: NUMBER OF PHASES	254	number of phases	1: Single phase input 2: Two-phase input	-	2	9-22
DROOPING CONTROL ENABLE	255	load share	0: Off 1: On ****	-	0	9-22
DROOPING CONTROL AMOUNT	256	Number of Hz droop at full load****	0.0 - 10.0% of Max. Out. Freq.	0.1%	0.0	9-22

*Table continued on next page*

\*Items 244 - 248 are available only when Item 243 Adjustment Range options 1 or 2 are selected.

\*\*Item 249 is available only when Item 243 Adjustment Range option 1 is selected.

\*\*\*Items 251 - 252 are available only when Item 250 Adjustment Range option 1 is selected.

\*\*\*\*Item 256 is available only when Item 255 Adjustment Range option 1 is selected.



**GROUP : FEEDBACK PARAMETERS (cont'd)**

LIQUID CRYSTAL DISPLAY	ITEM NO.	PARAMETER DESCRIPTION	ADJUSTMENT RANGE	DISPLAY RESOLUTION	FACTORY SETTING	PAGE NO.
OVERRIDE CONTROL SELECTION	257	trim source	0: Off 1: "RR" terminal 2: "IV" terminal 3: "RX" terminal 4: PG option board 5: Keypad 6: All other opt board 7: Multiplier	-	0	9-22
OVERRIDE MULTIPLIER INPUT SELECTION	258*	trim source selection	0: Reference 1: "RR" terminal. 2: "IV" terminal 3: "RX" terminal 4: Binary input	-	0	9-22
OVERRIDE CHANGE MULTIPLIER	259*	sets trim range	-100.0 - 100.0% of reference	0.1%	0.0	9-22

\*Items 258 - 259 are available only when Item 257 Adjustment Range option 7 is selected.

**GROUP : COMMUNICATION SETTING PARAMETERS**

LIQUID CRYSTAL DISPLAY	ITEM NO.	PARAMETER DESCRIPTION	ADJUSTMENT RANGE	DISPLAY RESOLUTION	FACTORY SETTING	PAGE NO.
RS232 BAUD RATE	260	set RS232 baud rate	0: 2400 baud 1: 4800 baud 2: 9600 baud	-	2	9-22
NUMBER OF DATA BITS	261	Number of data bits	0: 7 bits 1: 8 bits	-	0	9-22
PARITY SETTING	262	Parity	0: Even parity 1: Odd parity	-	0	9-22
INVERTER ID NUMBER	263	Inverter number	0 - 255	-	0	9-22
COMMUNICATION SELECTION	264	Communication selection	0: Off 1: RS485 board* 2: Tosline-F10, DN board, MB+ board, RIO board** 3: Tosline-S20 ** 4: 12-bit binary input (option board) 5: BCD board (0.1 Hz units) 6: BCD board (1 Hz units)	-	0	9-23
MASTER/SLAVE SELECTION	265*	Master/follower selection	0: Follower 1: Master (follower follows master freq. command) 2: Master (output frequency)	-	0	9-23
RS485 BAUD RATE	266*	RS485 baud rate	0: Normal mode 1: High speed mode	-	0	9-23
TOSLINE-F10/S20 COMMAND INPUT	267**	TOSLINE-F10/TOSLINE-S20 command input	0: Off 1: Frequency command 2: Command input 3: Frequency command, command input	-	0	9-23

*Table continued on next page*

\*Items 265 - 266 are available only when Item 264 Adjustment Range option 1 is selected.

\*\*Item 267 is available only when Item 264 Adjustment Range option 2 or 3 is selected.

**Cycle power after changing any parameter in GROUP : COMMUNICATION SETTING PARAMETERS.**

**GROUP : COMMUNICATION SETTING PARAMETERS (cont'd)**

LIQUID CRYSTAL DISPLAY	ITEM NO.	PARAMETER DESCRIPTION	ADJUSTMENT RANGE	DISPLAY RESOLUTION	FACTORY SETTING	PAGE NO.
TOSLINE-F10/S20 MONITOR OUTPUT	268*	TOSLINE-F10/TOSLINE-S20 monitor output	0: Off 1: Output frequency 2: Status 3: Output frequency, status 4: Output current 5: Output frequency, output current 6: Status, output current 7: Output frequency, status, output current 8: Output voltage 9: Output frequency, output voltage 10: Output voltage, status 11: Output frequency, output voltage, status 12: Output voltage, output current 13: Output voltage, output current, output frequency 14: Output voltage, output current, status 15: Output voltage, output current, output frequency, status	-	0	9-23
TOSLINE-F10/S20 COMM ERROR MODE	269	TOSLINE-F10 TOSLINE-S20 communication error mode	0: Data cleared 1: Data retained	-	0	9-23
RS485/12-BIT BINARY BIAS, GAIN	270	RS485/12-bit binary input: bias and gain settings	0: Off - 1: On **	0	0	9-23
RS485/12-BIT BINARY POINT #1	271**	Point #1 setting signal	0 - 100% of Max. Out. Freq.	1%	0	9-23
RS485/12-BIT BINARY POINT #1 FREQ	272**	Output Hz desired with input entered in Item 271	0 - Max. Out. Freq.	0.1/0.01 Hz	0.0	9-23
RS485/12-BIT BINARY POINT #2	273**	Point #2 setting signal	0 - 100% of Max. Out. Freq.	100%	0	9-23
RS485/12-BIT BINARY POINT #2 FREQ	274**	Output Hz desired with input entered in Item 273	0 - Max. Out. Freq.	0.1/0.01 Hz	Max Out Freq	9-23

\*Item 268 is available only when Item 264 Adjustment Range option 2 or 3 is selected.

\*\*Items 271 - 274 are available only when Item 270 Adjustment Range option 1 is selected.

**Cycle power after changing any parameter in GROUP : COMMUNICATION SETTING PARAMETERS.**

GROUP: INDUSTRIAL APPLICATION PARAMETERS (PUMP)

GROUP: INDUSTRIAL APPLICATION PARAMETERS (FAN)

GROUP: INDUSTRIAL APPLICATION PARAMETERS (CONVEYOR)

GROUP: INDUSTRIAL APPLICATION PARAMETERS (HOIST)

GROUP: INDUSTRIAL APPLICATION PARAMETERS (TEXTILES)

GROUP: INDUSTRIAL APPLICATION PARAMETERS (MACHINE TOOLS)

These groups contain the parameters likely to be used for certain applications. See the G3 Industrial Application Manual (available from your Toshiba distributor) for programming charts and macro values.

**GROUP: AM/FM TERMINAL ADJUSTMENT PARAMETERS**

LIQUID CRYSTAL DISPLAY	ITEM NO.	PARAMETER DESCRIPTION	ADJUSTMENT RANGE	FACTORY SETTING	PAGE NO.
FM TERMINAL FUNCTION SELECTION	275	"FM" terminal signal selection	0: Pre-compensation ref frequency 1: Post-compensation output frequency 2: Frequency reference 3: Output current 4: DC voltage 5: Output voltage 6: Torque current 7: Excitation current 8: PID feedback value 9: Motor overload ratio 10: Inverter overload ratio 11: DBR overload ratio 12: Input power 13: Output power 14: Meter calibration (100% fixed output) 15: Peak output current 16: Peak input voltage	0	9-23
FREQUENCY METER ADJUSTMENT	276	"FM" terminal calibration	-	-	9-24
AM TERMINAL FUNCTION SELECTION	277	"AM" terminal signal selection	0: Pre-compensation reference frequency 1: Post-compensation output frequency 2: Frequency setting value 3: Output current 4: DC voltage 5: Output voltage 6: Torque current 7: Excitation current 8: PID feedback value 9: Motor overload ratio 10: Inverter overload ratio 11: DBR overload ratio 12: Input power 13: Output power 14: Meter calibration (100% fixed output) 15: Peak output current 16: Peak input voltage	3	9-25
CURRENT METER ADJUSTMENT	278	"AM" terminal calibration	-	-	9-25

## GROUP: UTILITY PARAMETERS

LIQUID CRYSTAL DISPLAY	ITEM NO.	PARAMETER DESCRIPTION	ADJUSTMENT RANGE	FACTORY SETTING	PAGE NO.
INDUSTRIAL APPLICATIONS	279	selects application-specific programming (macros)	0: Does nothing 1: Pump application 2: Fan application 3: Conveyor application 4: Hoist application 5: Textiles application 6: Machine tool application	0	9-25
STANDARD SETTING MODE SELECTION	280	defaults drive parameters	0: Does nothing 1: 50 Hz setting 2: 60 Hz setting 3: Default drive to factory settings 4: Clear past trips in monitor 5: Store user default settings 6: Default to user default settings 7: Initialize inverter typeform	0	9-25
COMMAND MODE SELECTION	281	selects START/STOP command source	0: Only RS232C input valid 1: Terminal input valid 2: Panel input valid 3: RS485 option board 4: Keypad or terminal strip, as set by LOCAL/REMOTE button.	4	9-25
FREQUENCY MODE SELECTION	282	selects frequency reference source	0: Only RS232C input valid 1: Terminal input valid 2: Panel input valid 3: RS485 option board 4: Keypad or terminal strip, as set by LOCAL/REMOTE button	4	9-25
PANEL OPERATION MODE SELECTION	* 283	limits keypad's functions	0: Prohibit all key operations 1: Perform reset 2: Perform monitor operations 3: Perform reset, perform monitor operations 4: Perform emergency stop 5: Perform emergency stop, perform reset 6: Perform emergency stop, perform monitor operations 7: Perform emergency stop, perform monitor operations, perform reset 8: Perform run/stop operations 9: Perform run/stop operations, perform reset 10: Perform run/stop operations, perform monitor operations 11: Perform run/stop operations, perform monitor operations, perform reset 12: Perform run/stop operations, perform emergency stop 13: Perform run/stop operations, perform emergency stop, perform reset 14: Perform run/stop operations, perform emergency stop, perform monitor operations (cont'd)	63	9-26

*Table continued on next page*

**\* NOTE: Recycle power after changing ITEM 283, PANEL OPERATION MODE SELECTION. ESTOP from keypad while in remote mode cannot be disabled.**

**GROUP: UTILITY PARAMETERS (cont'd)**

LIQUID CRYSTAL DISPLAY	ITEM NO.	PARAMETER DESCRIPTION	ADJUSTMENT RANGE	FACTORY SETTING	PAGE NO.
PANEL OPERATION MODE SELECTION	* 283	Panel operation mode selection	(cont'd from p.8-28) 15: Perform run/stop operations, perform emergency stop, perform monitor operations, perform reset 16: Perform parameter read operations 17: Option 16 + Option 1 18: Option 16 + Option 2 19: Option 16 + Option 3 20: Option 16 + Option 4 21: Option 16 + Option 5 22: Option 16 + Option 6 23: Option 16 + Option 7 24: Option 16 + Option 8 25: Option 16 + Option 9 26: Option 16 + Option 10 27: Option 16 + Option 11 28: Option 16 + Option 12 29: Option 16 + Option 13 30: Option 16 + Option 14 31: Option 16 + Option 15 32: Perform parameter change operations 33: Option 32 + Option 1 34: Option 32 + Option 2 35: Option 32 + Option 3 36: Option 32 + Option 4 37: Option 32 + Option 5 38: Option 32 + Option 6 39: Option 32 + Option 7 40: Option 32 + Option 8 41: Option 32 + Option 9 42: Option 32 + Option 10 43: Option 32 + Option 11 44: Option 32 + Option 12 45: Option 32 + Option 13 46: Option 32 + Option 14 47: Option 32 + Option 15 48: Option 32 + Option 16 49: Option 32 + Option 17 50: Option 32 + Option 18 51: Option 32 + Option 19 52: Option 32 + Option 20 53: Option 32 + Option 21 54: Option 32 + Option 22 55: Option 32 + Option 23 56: Option 32 + Option 24 57: Option 32 + Option 25 58: Option 32 + Option 26 59: Option 32 + Option 27 60: Option 32 + Option 28 61: Option 32 + Option 29 62: Option 32 + Option 30 63: Standard mode (perform all operations)	63	9-26

**\* NOTE: Recycle power after changing ITEM 283, PANEL OPERATION MODE SELECTION.**

# TOSHIBA

## GROUP: UTILITY PARAMETERS (cont'd)

LIQUID CRYSTAL DISPLAY	ITEM NO.	PARAMETER DESCRIPTION	ADJUSTMENT RANGE	DISPLAY RESOLUTION	FACTORY SETTING	PAGE NO.
PASS NUMBER	284	Panel operation mode selection	0 - 99	-	0	9-26
CPU VERSION	285	CPU version	Can be monitored only	-	120	9-26
ROM VERSION	286	ROM version	Can be monitored only	-	-	9-26
EEPROM VERSION	287	EEPROM version	Can be monitored only	-	-	9-26
INVERTER TYPEFORM	288	Inverter typeform	Can be monitored only	-	-	9-26
STATUS MONITOR #1 DISPLAY SELECT	289	Programmable monitor #1 (displayed in MON mode)	1: post-compensation output frequency 2: frequency command setting 3: output current 4: input voltage 5: output voltage 6: torque current 7: excitation current 8: PID feedback value 9: motor overload ratio 10: inverter overload ratio 11: DBR overload ratio 12: input power 13: output power 14: RR input value 15: peak load current 16: peak input voltage	-	2	9-27
STATUS MONITOR #2 DISPLAY SELECT	290	Programmable monitor #2 (displayed in MON mode)	<i>Same options as Item 289</i>	-	3	9-27
STATUS MONITOR #3 DISPLAY SELECT	291	Programmable monitor #3 (displayed in MON mode)	<i>Same options as Item 289</i>	-	4	9-27
STATUS MONITOR #4 DISPLAY SELECT	292	Programmable monitor #4 (displayed in MON mode)	<i>Same options as Item 289</i>		5	9-27
FREQUENCY UNITS SCALE FACTOR	293	multiplier to scale Hz display	0 (Off), 0.01 - 200	0.01	0.00	9-27
FREQUENCY DISPLAY RESOLUTION	294	Frequency display resolution	0: 1 Hz 1: 0.1 Hz 2: 0.01 Hz	-	1	9-27
ACC/DEC TIME UNITS SELECTION	295	ACC/DEC time units selection	0: 0.1 secs- 1: 0.01 secs	0	9-27	
CURRENT UNITS SELECTION	296	Current units selection	0: % 1: A	-	0	9-27
VOLTAGE UNITS SELECTION	297	Voltage units selection	0: % 1: V	-	1	9-27

*Table continued on next page*



## GROUP: UTILITY PARAMETERS (cont'd)

LIQUID CRYSTAL DISPLAY	ITEM NO.	PARAMETER DESCRIPTION	ADJUSTMENT RANGE	FACTORY SETTING	PAGE NO.
BLIND FUNCTION SELECTION	298	Blind function selection	0: Items 299-315 blinded 1: View Items 299-315	0	9-27
FUNDAMENTAL PARAMS #2 BLIND	299*	This group must be unblinded to access group's parameters	0: Blind this group 1: Add this group to visible group list	0	9-27
PANEL CONTROL PARAMS BLIND	300*	This group must be unblinded to access group's parameters	0: Blind this group 1: Add this group to visiblegroup list	0	9-28
TERMINAL SELECTION PARAMS BLIND	301*	This group must be unblinded to access group's parameters	0: Blind this group 1: Add this group to visible group list	0	9-28
SPECIAL CONTROL PARAMS BLIND	302*	This group must be unblinded to access group's parameters	0: Blind this group 1: Add this group to visible group list	0	9-28
FREQUENCY SETTING PARAMS BLIND	303*	This group must be unblinded to access group's parameters	0: Blind this group 1: Add this group to visible group list	0	9-28
PROTECTION FUNCTION PARAMS BLIND	304*	This group must be unblinded to access group's parameters	0: Blind 1: Add this group to visible group list	0	9-28
PATTERN RUN CONTROL PARAMS BLIND	305*	This group must be unblinded to access group's parameters	0: Blind 1: Add this group to visible group list	0	9-28
FEEDBACK CONTROL PARAMS BLIND	306*	This group must be unblinded to access group's parameters	0: Blind 1: Add this group to visible group list	0	9-28
COMMUNICATION PARAMS BLIND	307*	This group must be unblinded to access group's parameters	0: Blind 1: Add this group to visible group list	0	9-28
INDUSTRIAL APPL: PUMP PARAMS BLIND	308*	This group must be unblinded to access group's parameters	0: Blind 1: Add this group to visible group list	0	9-28
INDUSTRIAL APPL: FAN PARAMS BLIND	309*	This group must be unblinded to access group's parameters	0: Blind 1: Add this group to visible group list	0	9-28
INDUSTRIAL APPL: CONVEYOR BLIND	310*	This group must be unblinded to access group's parameters	0: Blind 1: Add this group to visible group list	0	9-28
INDUSTRIAL APPL: HOIST BLIND	311*	This group must be unblinded to access group's parameters	0: Blind 1: Add this group to visible group list	0	9-28
INDUSTRIAL APPL: TEXTILES BLIND	312*	This group must be unblinded to access group's parameters	0: Blind 1: Add this group to visible group list	0	9-29
INDUSTRIAL APPL: TOOLS BLIND	313*	This group must be unblinded to access group's parameters	0: Blind 1: Add this group to visible group list	0	9-29
AM/FM ADJUSTMENT PARAMS BLIND	314*	This group must be unblinded to access group's parameters	0: Blind 1: Add this group to visible group list	0	9-29
MOTOR PARAMETERS BLIND	315*	This group must be unblinded to access group's parameters	0: Blind 1: Add this group to visible group list	0	9-29

\*Items 299 - 315 are available only when Item 298 Adjustment Range option 1 is selected.

**600 volt G3s have an additional group, GROUP: TRAVERSE CONTROL PARAMETERS that is unblinded via the parameter TRAVERSE CONTROL PARAMS UNBLIND. See Traverse Option ROM Instruction Manual for more information.**

## GROUP: MOTOR PARAMETERS

LIQUID CRYSTAL DISPLAY	ITEM NO.	PARAMETER DESCRIPTION	ADJUSTMENT RANGE	DISPLAY RESOLUTION	FACTORY SETTING	PAGE NO.
NUMBER OF MOTOR POLES	316	Number of motor poles	2, 4, 6, 8, 10, 12, 14, 16	2	4	9-29
MOTOR RATED CAPACITY	317	Motor rated capacity	0.1 - 999.9	0.1kW	*	9-29
MOTOR TYPE	318	Motor type	0: High efficiency motor 1: Standard motor 2: Other**	-	0	9-29
MOTOR RATED VOLTAGE	319**	Rated voltage for 400V inverter Rated voltage for 200V inverter Rated voltage for 600V inverter	90 - 600 90 - 600 130 - 860	5V 5V 5V	400 200 575	9-29 9-29 9-29
MOTOR RATED FREQUENCY	320**	Rated frequency	0 - 400	2 Hz	60	9-29
MOTOR RATED RPM	321**	Rated RPM	0 - 9999	1 RPM	1710	9-29
AUTO-TUNING ENABLE	322**	Auto-tuning ***	0: Auto-tuning disabled 1: Auto-tuning enabled	-	0	9-29
LOAD MOMENT OF INERTIA	323	Load moment of inertia	0: Small 1: Medium 2: Large 3: Very large	-	1	9-29

\*Item 317 factory setting depends on inverter rating (1 HP = .746kW)

\*\*Items 319 - 322 are available only when Item 318 Adjustment Range option 2 is selected.

\*\*\*Inverters sized 150 HP and larger cannot be auto-tuned.

## Parameter Tree

Fundamental Parameters #1	Fundamental Parameters #2	Panel Control Parameters	Special Control Parameters	Terminal Selection Parameters	Terminal Selection Parameters (continued)	Frequency Setting Parameters	Frequency Setting Parameters (continued)
1 Maximum Output Frequency	15 Base Frequency #2	25 Direction Selection Forward/Rev	31 Start up Frequency	43 Input Terminal Selection	62 "RCH" Contacts Hold Time	80 Frequency Priority Selection #1	100 PG Ref Point #1 Frequency
2 Base Frequency #1	16 Maximum Output Voltage #2	26 Stop Pattern Selection	32 End Frequency	44 "R" Input Terminal Function	63 "Low" Contacts Function	81 Frequency Priority Selection #2	101 PG Reference Setting Point #2
3 Base Frequency Voltage Select	17 Voltage Boost #2	27 Fundamental Param Switching	33 Run Frequency	45 "S1" Input Terminal Function	64 "Low" Contacts Delay Time	82 Analog Input Filter	102 PG Ref Point #2 Frequency
4 Maximum Output Voltage #1	18 Electronic Thermal Protect LVL #2	28 Accel/Decel #1/#2 Selection	34 Run Frequency Hysteresis	46 "S2" Input Terminal Function	65 "Low" Contacts Hold Time	83 RR Terminal Standard or Adjust.	103 Binary Input Std. or Adjustable
5 Reverse Operation Disable Select	19 Stall Protection Selection #2	29 Panel Reset Selection	35 Enable Jump Frequencies	47 "S3" Input Terminal Function	66 "FL" Contacts Function	84 RR Reference Setting Point #1	104 Binary Ref Setting Point #1
6 Upper Limit Freq.	20 Stall Protection Level #2	30 Panel Feedback Control	36 Jump Frequency #1	48 "S4" Input Terminal Function	67 "FL" Contacts Delay Time	85 RR Ref Point #1 Frequency	105 Binary Ref Point #1 Frequency
7 Lower Limit Freq.	21 Acceleration Time #2		37 Jump Frequency #1 Bandwidth	49 "F" Input Terminal Function	68 "FL" Contacts Hold Time	86 RR reference Setting Point #2	106 Binary Ref Setting point #2
8 Volts per hertz Pattern	22 Deceleration Time #2		38 Jump Frequency #2	50 "RES" Input Terminal Function	69 "OUT" Contacts Function	87 RR Ref Point #2 Frequency	107 Binary Ref Point #2 Frequency
9 Voltage Boost #1	23 Acc/Dec Pattern #2		39 Jump Frequency #3 Bandwidth	51 "ST" Input Terminal Function	70 "OUT" Contacts Delay Time	88 IV Terminal Standard or Adj.	108 Jog Run Frequency
10 Acceleration Time #1	24 Acc/Dec #1/#2 Switch Frequency		40 Jump Frequency #3	52 "S5" Input Terminal Function	71 "OUT" Contacts Hold Time	89 IV Reference Setting Point #1	109 Jog Stop Method
11 Deceleration Time #1			41 Jump Frequency #3 Bandwidth	53 "S6" Input Terminal Function	72 Low Speed Signal Output Freq	90 IV Ref Point #1 Frequency	110 Preset Speed Selection
12 Acc/Dec Pattern #1 Selection			42 PWM Carrier Frequency	54 "S7" Input Terminal Function	73 Acc/Dec Complete Detect Band	91 IV Reference Setting Point #2	111 Preset Speed Mode Activation
13 Accel/Decel Pattern Adjust Low				55 Potential Terminal Function	74 Speed Reach Max. Frequency	92 IV Ref Point #2 Frequency	112 Preset Speed #1 Frequency
14 Accel/Decel Pattern Adjust High				56 R, S1-S7 Terminal Response Time	75 Speed Reach Min. Frequency	93 RX Terminal Standard or Adjust.	113 Preset Speed #1 Operating Mode
				57 "F" Input Terminal Response Time	76 Commercial Power Inv Switch Output	94 RX Reference Setting Point #1	114 Preset Speed #2 Frequency
				58 "RES" Terminal Response Time	77 Commercial Pwr / Inv Switch Freq	95 RX Ref Point #1 Frequency	115 Preset Speed #2 Operating Mode
				59 "ST" Input Terminal Response Time	78 "FP" Output Terminal Pulse Freq.	96 RX Reference Setting Point #2	116-139 Preset Speeds 3-14 Oper. Modes #3-14
				60 "RCH" Contacts Function	79 RR Input Special Function Select	97 RX Ref Point #2 Frequency	140 Preset Speed #15 Frequency
				61 "RCH" Contacts Delay Time		98 PG Terminal Standard or Adjust.	141 Preset Speed #15 Operating Mode
						99 PG Reference Setting Point #1	

**LEGEND FOR PARAMETER TREE**

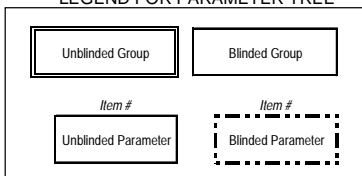

600 V G3s HAVE ANOTHER GROUP NOT COVERED IN THIS MANUAL  
See Page 8-31

## Parameter Tree (cont'd)

Protection Parameters	Protection Parameters (Continued)	Pattern Run Control Parameters	Feedback Parameters	Communication Setting Parameters	AM/FM Terminal Adjustment Parameters	Utility Parameters	Utility Parameters (Continued)	Motor Parameters
142 Dynamic Braking Selection	160 Motor 150% Overload Time Limit	175 Pattern Run Selection	243 Feedback Control Selection	260 RS232 Baud Rate	275 FM Terminal Function Selection	279 Industrial Applications	296 Current Units Selection	316 Number of Motor Poles
143 Braking Resistor Value	161 Overload Selection	176 Pattern Run Continue Mode	244 Feedback Input Signal Selection	261 Number of Data Bits	276 Frequency Motor Adjustment	280 Standard Setting Mode Selection	297 Voltage Units Selection	317 Motor Rated Capacity
144 Braking Resistor Power Rating	162 Stall Protection Enable	177-184 Pattern Group #1 Speeds #0 - #7	245 Proportional Gain	262 Parity Setting	277 AM Terminal Function Selection	281 Command Mode Selection	298 Blind Function Selection	318 Motor Type
145 Overvoltage Stall Protection	163 Stall Protection Current Level	185 Pattern Group #1 Number of Cycles	246 Integral Gain	263 Inverter ID Number	278 Current Meter Adjustment	282 Frequency Mode Selection	299 Fundamental Parameters #2 Blind	319 Motor Rated Voltage
146 DC Injection Start Frequency	164 Undervoltage Trip Selection	186-193 Pattern Group #2 Speeds #0 - #7	247 Anti Hunting Gain	264 Communication Selection		283 Panel Operation Mode Selection	300 Panel Control Parameters Blind	320 Motor Rated Frequency
147 DC Injection Current Magnitude	165 Undervoltage Detect Time	194 Pattern Group #3 Number of Cycles	248 Lag Time Constant	265 Master/Slave Selection		284 Pass Number	301 Terminal Selection Parameters Blind	321 Motor Rated RPM
148 DC Injection Time	166 Low Current Detect Selection	195-202 Pattern Group #3 Speeds #0 - #7	249 PID Lower Frequency Limit	266 RS485 Baud Rate		285 CPU Version	302 Special Control Params Blind	322 Auto-Tuning Enable
149 Fwd/Rev DC Inj. Priority control	167 Low Current Detect Level	203 Pattern Group #3 Number of Cycles	250 PID Deviation Limit Selection	267 TOSLINE F10/S20 Command Input		286 ROM Version	303 Frequency Setting Params Blind	323 Load Moment of Inertia
150 Motor Shaft stationary control	168 Low Current Detection Time	204-211 Pattern Group #4 Speeds #0 - #7	251 PID Deviation Upper Limit	268 TOSLINE F10/S20 Monitor Output		287 EEPROM Version	304 Protection Function Params Blind	
151 Emergency Off Mode Selection	169 Output Short Circuit Detection Select	212 Pattern Group #4 Number of Cycles	252 PID Deviation Lower limit	269 TOSLINE F10/S20 Comm Error Mode		288 Inverter TypeForm	305 Pattern Run Control Params Blind	
152 Emergency Off DC Injection Time	170 Overtorque Trip Selection	213 Speed #1 Continue Mode	253 PG Input Number of Pulses	270 RS485/12-Bit Binary Bias, Gain		289 Status Monitor #1 Display Select	306 Feedback Control Params Blind	
153 Number of Retry Attempts	171 Overtorque Trip Level	214 Speed #1 Drive Time	254 PG Input Number of Phases	271 RS485/12-Bit Binary point #1		290 Status Monitor #2 display Select	307 Communication Params Blind	
154 Time Between Retry Attempts	172 Fault Trip EEPROM Save Enable	215-242 Speeds 2 - 15 Drive Time	255 Drooping Control Enable	272 RS485/12-Bit Binary pt. #1 Freq		291 Status Monitor #3 Display Select	308 Industrial Appl: Pump Params Blind	
155 Regeneration Power Ride Through	173 Cooling Fan Control Selection	215 - 242 Speeds 2-15 Continue mode	256 Drooping Control Amount	273 RS485/12-Bit Binary point #2		292 Status Monitor #4 Display Select	309 Industrial Appl: Fan Params Blind	
156 Regeneration Ride Through time	174 Cumulative Run Timer Alarm Setting		257 Override Control Selection	274 RS485/12-Bit Binary pt. #2 Freq		293 Frequency Units Scale Factor	310 Industrial Appl: Conveyor Blind	
157 Auto-restart (motor speed search)			258 Override Multiplier Input Selection			294 Frequency Display Resolution	311 Industrial Appl: Hoist Blind	
158 Electronic Thermal Protect Level 1			259 Override Change Multiplier			295 ACC/DEC Time Units Selection	312 Industrial Appl: Textiles Blind	
159 Overload Reduction Start Freq.							313 Industrial Appl: Tools Blind	
							314 AM/FM Adjustment Params Blind	
							315 Motor Parameters Blind	

## SECTION 9: Programming

Note: The G3 will "kick out" of programming mode (return to OUTPUT FREQUENCY display) when a parameter name is displayed for fourteen seconds after the previous parameter has been read and written.

Press the PRG button to access the G3's programming mode. The drive now displays the first of the available groups. The G3 parameters that have related functions are gathered into families called groups. Use the up/down arrows to scroll through the available group list.

### Groups

With factory default programming, the G3 displays only three groups:

GROUP: PARAMETERS CHANGED FROM FACTORY DEFAULT  
GROUP: FUNDAMENTAL PARAMETERS #1  
GROUP: UTILITY PARAMETERS

The following is a list of all G3 groups:

GROUP: PARAMETERS CHANGED FROM FACTORY DEFAULT  
GROUP: FUNDAMENTAL PARAMETERS #1  
GROUP: FUNDAMENTAL PARAMETERS #2  
GROUP: PANEL CONTROL PARAMETERS  
GROUP: SPECIAL CONTROL PARAMETERS  
GROUP: TERMINAL SELECTION PARAMETERS  
GROUP: FREQUENCY SETTING PARAMETERS  
GROUP: PROTECTION PARAMETERS  
GROUP: PATTERN RUN CONTROL PARAMETERS  
GROUP: FEEDBACK PARAMETERS  
GROUP: COMMUNICATION SETTING PARAMETERS  
GROUP: INDUSTRIAL APPLICATION PARAMETERS (PUMP)  
GROUP: INDUSTRIAL APPLICATION PARAMETERS (FAN)  
GROUP: INDUSTRIAL APPLICATION PARAMETERS (CONVEYOR)  
GROUP: INDUSTRIAL APPLICATION PARAMETERS (HOIST)  
GROUP: INDUSTRIAL APPLICATION PARAMETERS (TEXTILES)  
GROUP: INDUSTRIAL APPLICATION PARAMETERS (MACHINE TOOLS)  
GROUP: AM/FM TERMINAL ADJUSTMENT PARAMETERS  
GROUP: UTILITY PARAMETERS  
GROUP: MOTOR PARAMETERS

600 volt G3s have another group for traverse control; see the traverse control ROM manual for information on using this group. A flowchart showing all groups and parameters can be found on pages 8-33 and 8-34. Item numbers are included for reference within the manual only; the drive does not recognize or display item numbers.

### Programming Example 1

Objective: Set ACCELERATION TIME #1 to 23.4 seconds.

Step 1: ACCELERATION TIME #1 (Item 10) is in GROUP: FUNDAMENTAL PARAMETERS #1, so press the PRG key and use the up/down arrows to scroll through the group list until GROUP: FUNDAMENTAL PARAMETERS #1 is displayed.

Step 2: Press the READ/WRITE key. Drive will then display MAXIMUM OUTPUT FREQUENCY (Item 1), because MAXIMUM OUTPUT FREQUENCY is the first parameter in GROUP: FUNDAMENTAL PARAMETERS #1.

Step 3: Use the up/down arrows to scroll through the parameters in GROUP: FUNDAMENTAL PARAMETERS #1 until the desired parameter (in this case, ACCELERATION TIME #1), is displayed.

Step 4: Press the READ/WRITE key. Drive will display the value stored in this parameter.

Step 5: Adjust displayed value with up/down arrow keys. Press READ/WRITE when finished. Drive flashes WRT to confirm entry.

Step 6: Use up/down arrows to select another parameter in this group, or press PRG to exit.

## Blinding

To make the G3's many parameters more manageable, Toshiba employs "blinded" parameters and "blinded" groups.

### BLINDED PARAMETERS

Item 9, VOLTAGE BOOST #1, is an example of a "blinded" parameter. A blinded parameter is identified in the parameter charts (which start on page 8-1) by its gray shading. A "blinded" parameter is preceded by a parameter that has a shaded choice in the Adjustment Range column (like Item 8, VOLTS PER HERTZ PATTERN). Item 9, VOLTAGE BOOST #1, is visible to the programmer only if item 8, VOLTS PER HERTZ PATTERN, is set to "1" or "2". Note how Adjustment Range 1 and 2 are shaded to indicate this. There are many other blinded parameters in the G3.

### BLINDED GROUPS

Of the twenty groups in the G3 (21 for 600V drive), only three are accessible when the drive is programmed with factory defaults. To adjust a parameter that is not in one of the three visible groups, that parameter's group must first be added to the group list. This is done in GROUP: UTILITY PARAMETERS, which is one of the visible groups.

## Programming Example 2

Objective: Change ELECTRONIC THERMAL PROTECT LEVEL 1 in GROUP: PROTECTION PARAMETERS to 89%.

Note 1: ELECTRONIC THERMAL PROTECT LEVEL 1 is in a group that is not one of the three groups visible when the drive is programmed with factory defaults. Therefore, GROUP: PROTECTION PARAMETERS will have to be added to the visible group list.

Note 2: GROUP: PROTECTION PARAMETERS is added to the visible group list by changing item 304, PROTECTION FUNCTION PARAMETERS BLIND in GROUP: UTILITY PARAMETERS to "1". To change item 304, however, it must first be unblinded by setting Item 298, BLIND FUNCTION SELECTION in GROUP: UTILITY PARAMETERS to "1".

Step 1: Press PRG and use up arrow to display GROUP: UTILITY PARAMETERS. Press READ/WRITE key. Drive will display INDUSTRIAL APPLICATIONS because it is the first parameter in the group.

Step 2: Instead of using the down arrow to go through all the parameters in GROUP: UTILITY PARAMETERS, use the up arrow to make the drive display the last visible parameter in GROUP: UTILITY PARAMETERS, which is item 298, BLIND FUNCTION SELECTION.

Step 3: Press READ/WRITE and adjust the "0" to a "1" using the arrow keys. Press READ/WRITE again. Drive flashes WRT to confirm entry.

Step 4: Items 299-315 are now unblinded. Use the down arrow to display PROTECTION FUNCTION PARAMETERS BLIND. Press READ/WRITE, use the up arrow to change the "0" to a "1", and press READ/WRITE again. Drive flashes WRT to confirm entry.

Step 5: Press PRG twice to return to the group list. Use the arrows to verify that a fourth group, GROUP: PROTECTION PARAMETERS is now a part of the group list.

Step 6: Press READ/WRITE to enter the group. Drive will display Item 142, DYNAMIC BRAKING SELECTION because that parameter is the first in the group.

Step 7: Use the down arrow to reach Item 158, ELECTRONIC THERMAL PROTECT LEVEL 1.

Step 8: Press READ/WRITE. Using the arrows, adjust the value to "89". Press READ/WRT. Drive flashes WRT to confirm entry.

Step 9: Press PRG to leave programming.

## Search Function

When GROUP: PARAMETERS CHANGED FROM FACTORY DEFAULT is displayed and READ/WRITE is pressed, the drive will display SEARCHING. Any displayed parameters have been changed to a value different from Toshiba's default. Press READ/WRITE to see the value of the parameter. The parameter can be modified with the up/down arrows. Pressing READ/WRITE again resumes the drive's search.

## Parameter Explanations

GROUP: FUNDAMENTAL PARAMETERS #1 and GROUP: FUNDAMENTAL PARAMETERS # 2 allow the user to store unique V/Hz, accel/decel, etc. parameters for two motors to be operated on one drive at different times.

Item 1, MAXIMUM OUTPUT FREQUENCY - This parameter cannot be changed while the motor is running, and affects accel/decel times, binary frequency references, and many other parameters and functions. To limit the drive's output frequency range, adjust UPPER LIMIT FREQUENCY and/or LOWER LIMIT FREQUENCY (see Items 6 and 7 below).

Item 2, BASE FREQUENCY #1 - This parameter sets the frequency at which the drive's output voltage reaches its maximum.

Item 3, BASE FREQUENCY VOLTAGE SELECTION - The parameter affects the drive's maximum output voltage as follows:

- 0: The output voltage fluctuates with the input voltage.
- 1: The output voltage is set according to the input voltage when the drive is first powered.
- 2: The output voltage is set by Item 4, MAXIMUM OUTPUT VOLTAGE #1.

Item 4, MAXIMUM OUTPUT VOLTAGE #1 - This parameter sets the drive's maximum output voltage. The output voltage cannot exceed the input voltage.

Item 5, REVERSE DISABLE OPERATION SELECTION - The G3 will not run in reverse with this parameter set to '1'.

Item 6, UPPER LIMIT FREQUENCY - This parameter sets the maximum frequency the G3 will output, regardless of reference.

Item 7, LOWER LIMIT FREQUENCY - This parameter sets the lowest speed the drive can run, regardless of reference. If this parameter is set to a non-zero value and the drive is given a run command (i.e. F-CC closure or RUN button), the drive will run at LOWER LIMIT FREQUENCY if the reference is less than LOWER LIMIT FREQUENCY.

Item 8, VOLTS PER HERTZ PATTERN - This parameter cannot be changed while the motor is running. The value here sets the way the output voltage changes with output frequency:

- 1: Constant torque: Drive varies its output voltage linearly with its output hertz change (at 30 Hz, output voltage is approximately half of what it is at 60 Hz).
- 2: Variable torque: Drive varies its output voltage as the square of its output hertz change (at 30 Hz, output voltage is approximately 1/4 of what it is at 60 Hz).
- 3: Automatic torque boost: Drive increases its output voltage at low output Hz to increase motor starting torque.
- 4: Automatic torque boost with energy saving feature: Same as number 3 above, but drive lowers output voltage during lightly-loaded periods (reduces idle amps).
- 5: True torque control: Drive maximizes torque developed by motor and compensates for motor slip. Item 298, BLIND FUNCTION SELECTION and Item 315, MOTOR PARAMETERS BLIND, must also be set to "1" so that GROUP: MOTOR PARAMETERS can be adjusted (see page 8-31).
- 6: True torque control with energy saving feature: Same as number 5 above, but drive lowers output voltage during lightly-loaded periods (reduces idle amps).

## Parameter Explanations (cont'd)

Item 9, VOLTAGE BOOST #1 - This parameter increases output voltage at low Hz to enable a motor operated in constant or variable torque modes to develop more starting torque. Too much voltage boost could result in an overcurrent trip.

Item 10, ACCELERATION TIME #1 (AT#1)

AT#1 sets the time for drive output frequency to go from 0 Hz to MAXIMUM OUTPUT FREQUENCY (Item 1). A small acceleration time may result in an overcurrent trip.

Item 11, DECELERATION TIME #1 (DT#1)

This parameter sets the time for drive output frequency to go from MAXIMUM OUTPUT FREQUENCY (Item 1) to 0 Hz. A small deceleration time may result in an overvoltage trip.

Item 12, ACC/DEC PATTERN #1

This value determines the way the drive's output frequency varies with time during an accel or decel as follows:

- 0: Linear pattern - Drive's output frequency change is linear with respect to time. For example, if the G3's output goes from 0 to 30 Hz in 5 seconds, it will take 10 seconds to go from 0 to 60 Hz.
- 1: Self-adjusting - Drive changes value in AT#1 and DT#1 based on current during accel and bus voltage during decel to prevent overcurrent/overvoltage trips. Every time a run/stop is executed, the G3 changes existing data in AT#1 and DT#1 (RAM). Drive may require a few run/stop commands to optimize value. To store modified AT#1 and DT#1 values, read value in AT#1 and DT#1 then press READ/WRITE to write values into memory (EEPROM).
- 2: S pattern - Drive output frequency's rate of change is slow near beginning and end of accel/ decel.

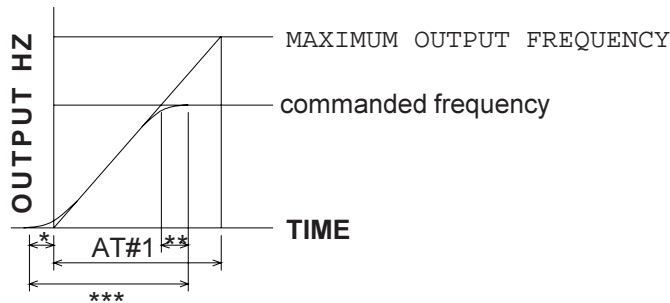

- \* S pattern accel time contributed by Item 13, ACCEL/DECEL PATTERN ADJUST LOW
- \*\* S pattern accel time contributed by Item 14, ACCEL/DECEL PATTERN ADJUST HIGH
- \*\*\* Total S pattern accel time

Drive follows similar curve during decel.

- 3: Overspeed pattern - When outputting a frequency greater than the motor's base frequency, drive extends accel/decel time to reduce possibility of overload trip due to reduction in torque.

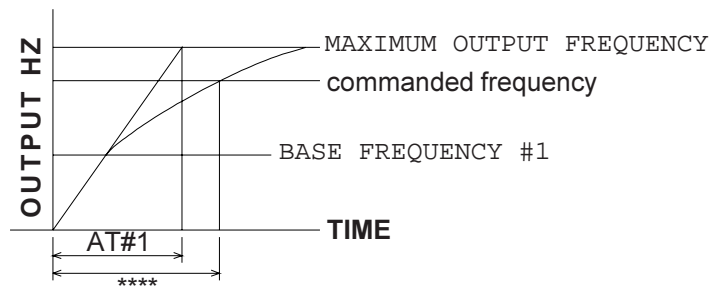

\*\*\*\* Actual accel time



## Parameter Explanations (cont'd)

Item 13, ACCEL/DECEL PATTERN ADJUST LOW - expressed as a percentage of Item 10, this time is represented as "\*" in the graph of S Pattern for Item 12.

Item 14, ACCEL/DECEL PATTERN ADJUST HIGH - expressed as a percentage of Item 10, this time is represented as "\*\*\*" in the graph of S Pattern for Item 12.

### **Note for** GROUP:FUNDAMENTAL PARAMETERS #2

The parameters in this group are similar to those found in GROUP: FUNDAMENTAL PARAMETERS #1. These two groups allow the user to program the drive for operation with two different motors (only one motor connected to drive at a time). The user can determine if GROUP: FUNDAMENTAL PARAMETERS #1 or if GROUP: FUNDAMENTAL PARAMETERS #2 is active by setting Item 27, FUNDAMENTAL PARAM SWITCHING as desired or by setting one of the drive's input terminal's function to "12" and opening/closing that terminal to the CC terminal. The user can also determine if ACCELERATION TIME #1/DECELERATION TIME #1 or ACCELERATION TIME #2/DECELERATION TIME #2 is active by setting Item 28, ACCEL/DECEL #1/#2 SELECTION or by setting one of the drive's input terminal's functions to "9" and opening/closing that terminal to the CC terminal. See page 9-7 for more information on programming the input terminals.

Item 15, BASE FREQUENCY #2 - see item 2, BASE FREQUENCY #1

Item 16, MAXIMUM OUTPUT VOLTAGE #2 - see item 4, MAXIMUM OUTPUT VOLTAGE #1

Item 17, VOLTAGE BOOST #2 - see item 9, VOLTAGE BOOST #1

Item 18, ELECTRONIC THERMAL PROTECT LEVEL #2 - This parameter lowers the drive's overload to protect the motor. Divide motor full-load amps by drive full-load amps and multiply by one hundred. Enter the result in this parameter. Input in amps with item 296, CURRENT UNITS SELECTION, is set to "1".

Item 19, STALL PROTECTION SELECTION #2 - Stall is a drive function wherein the drive limits the motor current by reducing output voltage and frequency in an effort to reduce load. Stall is most effective on variable torque loads. This parameter turns stall off/on.

Item 20, STALL PROTECTION LEVEL #2 - Enter the current limit in amps or in percent of drive rating. See Item 296, CURRENT UNITS SELECTION, to change units from % to amps.

Item 21, ACCELERATION TIME #2 - see item 10, ACCELERATION TIME #1

Item 22, DECELERATION TIME #2 - see item 11, DECELERATION TIME #1

Item 23, ACC/DEC PATTERN #2 SELECTION - see item 12, ACC/DEC PATTERN #1 SELECTION

Item 24, ACC/DEC #1/#2 SWITCHING FREQUENCY - The drive can be programmed to switch from accel/decel time #1 to accel/decel time #2 based on output frequency. Enter the Hz at which the drive should switch from accel/decel time #1 to accel/decel time #2.

Item 25, DIRECTION SELECTION (FORWARD/REVERSE) - This parameter determines direction when commanding start/stop from keypad. Direction can also be changed from the keypad by pressing READ/WRITE and the up or down arrow simultaneously (with Item 25 set to "1").

Item 26, STOP PATTERN SELECTION - This parameter determines whether the drive follows the decel curve when the STOP button is pressed or if it performs a coast-stop. Coast stop is also performed when ST-CC is broken.

Item 27, FUNDAMENTAL PARAM SWITCHING - This parameter determines whether GROUP: FUNDAMENTAL PARAMETERS #1 or GROUP:FUNDAMENTAL PARAMETERS #2 is used.

## Parameter Explanations (cont'd)

Item 28, ACC/DEC #1 OR #2 SELECTION - If the keypad is being used for the RUN/STOP command, then change this parameter to choose which times and pattern are currently utilized. If the drive is getting a run/stop command via the terminal strip (i.e. "F"- "CC" made or "R"- "CC" made), the user can remotely choose which accel/decel is used by the drive by programming one of the input terminal's functions (see items 44-54) to a value of "9" and then closing this terminal to "CC" when acc/dec #2 is to be used. See item 24, ACC/DEC #1/#2 SWITCH FREQUENCY to change which acc/dec time is used based on drive's output Hz.

Item 29, PANEL RESET SELECTION - Use this parameter to limit the type of fault that can be manually reset from the panel:

- 0: Overcurrents, overloads, overvoltages, and overheat
- 1: Only overload faults
- 2: Only overload and overcurrent faults

Item 30, PANEL FEEDBACK CONTROL - Turns feedback on/off when stop/starting from keypad. "0" allows keypad to set setpoint. "1" turns feedback off, letting keypad act as a regular frequency reference.

Item 31, START-UP FREQUENCY - Drive's output frequency remains at 0 Hz until reference commands an output frequency greater than START-UP FREQUENCY. When the reference is great enough, drive immediately outputs commanded frequency (no accel ramp).

Item 32, END FREQUENCY - Drive's output frequency immediately goes to 0 Hz (no decel ramp) when reference commands an output frequency less than or equal to END FREQUENCY.

Item 33, RUN FREQUENCY (Frun) - Use in conjunction with item 34, below. This parameter is the center of the hysteresis band.

Item 34, RUN FREQUENCY HYSTERESIS (Fhys) - Use this parameter as a +/- bandwidth around RUN FREQUENCY. When the reference signal reaches a value that commands a frequency of  $F_{run} + F_{hys}$ , the drive's output frequency will ramp up to the corresponding frequency. The G3 will continue to follow the reference until the frequency it is commanding falls below  $F_{run} - F_{hys}$ , at which time the drive will decel to 0 Hz.

Items 33 and 34 are not effective when PID control is operating.

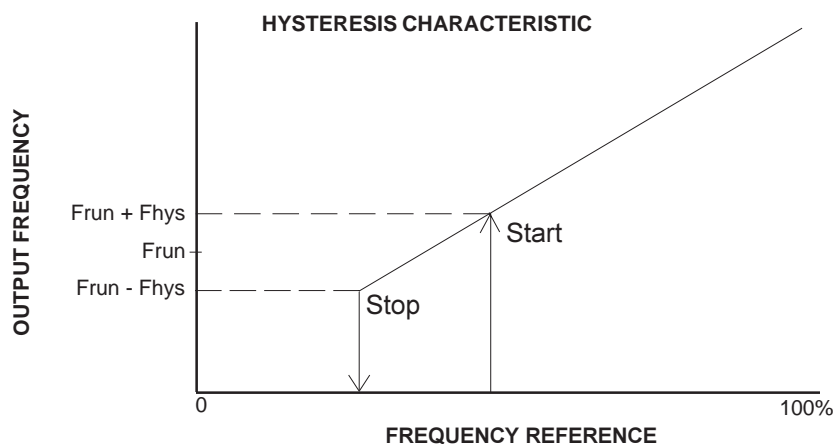

Item 35 JUMP FREQUENCY ENABLE - This parameters allows the programming of "Jump Frequencies", which are bands of output frequencies the drive will not continuously output. The drive allows the user to program up to three separate frequencies along with a bandwidth for each.

Item 36 JUMP FREQUENCY #1 - Enter the jump frequency.

## Parameter Explanations (cont'd)

Item 37 JUMP FREQUENCY BAND #1 - Enter the bandwidth for JUMP FREQUENCY #1. The value entered here will be added to and subtracted from JUMP FREQUENCY #1 to determine the upper and lower frequencies of the deadband.

Item 38 JUMP FREQUENCY #2 - see item 36.

Item 39 JUMP FREQUENCY BAND #2 - see item 37.

Item 40 JUMP FREQUENCY #3 - see item 36.

Item 41 JUMP FREQUENCY BAND #3 - see item 37.

### Example of Jump Frequency:

Suppose JUMP FREQUENCY #1 is set to 30 Hz and JUMP FREQUENCY BAND #1 is set to 5 Hz. Suppose a frequency reference starts commanding 0 Hz and slowly increases. The drive's output frequency slowly increases. When the reference hits a level that is commanding 25 Hz (30 - 5 Hz), the drive's output frequency stays at 25 Hz even though the reference continues to increase.

When the reference hits a level that commands 35 Hz (30+5 Hz), the drive accelerates (using the selected acceleration time) from 25 Hz to 35 Hz and continues to increase as the reference increases. During a decel, the drive will "stick" at 35 Hz until the reference hits a level that commands 25 Hz, at which time the drive decelerates (using the selected decel time) from 35 Hz to 25 Hz, and resumes following the reference.

Item 42 PWM CARRIER FREQUENCY - Use this function to change the frequency of the motor's acoustic noise. Above 8 KHz, the drive derates its current capability (100 HP and smaller).

Item 43 INPUT TERMINAL SELECTION - With this parameter set to "0", the drive's input terminals, when shorted to "CC", have the following default functions: "R" terminal gives reverse run command, "F" terminal gives forward run command, "RES" terminal resets a fault, "ST" terminal enables drive, "S1", "S2", "S3", and "S4" terminals give preset speed references. The user has the option of changing the function assigned to any of the G3's input terminals by programming a "1" into item 43 and programming the following parameters as necessary.

Item 44, "R" INPUT TERMINAL FUNCTION - sets the function realized when the "R" terminal is shorted to "CC". Default setting gives a reverse run command. See page 9-9 for codes for other available functions.

Item 45, "S1" INPUT TERMINAL FUNCTION - sets the function realized when the "S1" terminal is shorted to "CC". Default setting gives a preset speed reference. See page 9-9 for codes for other available functions.

Item 46, "S2" INPUT TERMINAL FUNCTION - sets the function realized when the "S2" terminal is shorted to "CC". Default setting gives a preset speed reference. See page 9-9 for codes for other available functions.

Item 47, "S3" INPUT TERMINAL FUNCTION - sets the function realized when the "S3" terminal is shorted to "CC". Default setting gives a preset speed reference. See page 9-9 for codes for other available functions.

Item 48, "S4" INPUT TERMINAL FUNCTION - sets the function realized when the "S4" terminal is shorted to "CC". Default setting gives a preset speed reference. See page 9-9 for codes for other available functions.

Item 49, "F" INPUT TERMINAL FUNCTION - sets the function realized when the "F" terminal is shorted to "CC". Default setting gives a forward run command. See page 9-9 for codes for other available

## Parameter Explanations (cont'd)

Item 50, "RES" INPUT TERMINAL FUNCTION - sets the function realized when the "RES" terminal is shorted to "CC". Default setting resets a fault. See page 9-9 for codes for other available functions.

Item 51, "ST" INPUT TERMINAL FUNCTION - sets the function realized when the "ST" terminal is shorted to "CC". Default setting enables the drive. See page 9-9 for codes for other available functions.

Item 52, "S5" INPUT TERMINAL FUNCTION - sets the function realized when the "S5" terminal is shorted to "CC". Default setting gives a binary speed reference bit. The "S5" terminal is available on the option boards INV3-COM-B and INV3-COM-D. See page 9-9 for codes for other available functions.

Item 53, "S6" INPUT TERMINAL FUNCTION - sets the function realized when the "S6" terminal is shorted to "CC". Default setting gives a binary speed reference bit. The "S6" terminal is available on the option boards INV3-COM-B and INV3-COM-D. See page 9-9 for codes for other available functions.

Item 54, "S7" INPUT TERMINAL FUNCTION - sets the function realized when the "S7" terminal is shorted to "CC". Default setting gives a binary speed reference bit. The "S7" terminal is available on the option boards INV3-COM-B and INV3-COM-D. See page 9-9 for codes for other available functions.

Item 55, POTENTIAL TERMINAL FUNCTION - The potential terminal is an imaginary terminal that the drive considers always shorted to "CC". Any function code from page 9-9 entered here will always be active. For example, if a value of "10" is programmed here, the drive will always ESTOP

Notes on input terminals' functions:

1. If the same function is assigned to more than one input terminal, 'OR' logic is in effect.
2. If none of the input terminals' function is set to "7" (enable), the drive will assume the drive enabled (just like ST-CC is made).

## Parameter Explanations (cont'd)

The following are the functions that are realized when the appropriate G3 terminal is shorted to "CC". Program the desired code from the list below into items 44-55 (see). **Contact the factory on how to make a function active when the terminal is disconnected from "CC" (fail-safe).**

Code	Function
0	Reverse direction command (default for "R" terminal function)
1	Binary coding for number of preset speed desired. Value: +1 (default for "S1" terminal function)
2	Binary coding for number of preset speed desired. Value: +2 (default for "S2" terminal function)
3	Binary coding for number of preset speed desired. Value: +4 (default for "S3" terminal function)
4	Binary coding for number of preset speed desired. Value: +8 (default for "S4" terminal function)
5	Forward direction command (default for "F" terminal function)
6	Reset faults (momentary falling-edge trigger) (default for "RES" terminal function)
7	Drive enable (default for "ST" terminal function)
8	Jog (also need direction command). See items 108 and 109.
9	Select ACC1/DEC1 (open) or ACC2/DEC2 (closed to "CC")
10	Emergency stop. Also see item 151, EMERGENCY OFF MODE SELECTION.
11	DC injection. When outputting a frequency under DC INJECTION START FREQUENCY, short terminal to "CC" to inject. Also see items 146, 147, and 148. Works in remote mode only.
12	Activate GROUP:FUNDAMENTAL PARAMETERS #1 (open) or GROUP:FUNDAMENTAL PARAMETERS #2 (closed to "CC")
13	PID off (closed to "CC") or on (open)
14	Select Pattern Run #1
15	Select Pattern Run #2
16	Select Pattern Run #3
17	Select Pattern Run #4
18	Pattern Run continue signal
19	Pattern Run step signal
20	Jog forward (includes forward command). See items 108 and 109.
21	Jog reverse (includes reverse command). See items 108 and 109.
22	Bit #0 for binary speed reference (value of MAXIMUM OUTPUT FREQUENCY/2048)
23	Bit #1 for binary speed reference (value of MAXIMUM OUTPUT FREQUENCY/1024)
24	Bit #2 for binary speed reference (value of MAXIMUM OUTPUT FREQUENCY/512)
25	Bit #3 for binary speed reference (value of MAXIMUM OUTPUT FREQUENCY/256)
26	Bit #4 for binary speed reference (value of MAXIMUM OUTPUT FREQUENCY/128)
27	Bit #5 for binary speed reference (value of MAXIMUM OUTPUT FREQUENCY/64)
28	Bit #6 for binary speed reference (value of MAXIMUM OUTPUT FREQUENCY/32)
29	Bit #7 for binary speed reference (value of MAXIMUM OUTPUT FREQUENCY/16)
30	Bit #8 for binary speed reference (value of MAXIMUM OUTPUT FREQUENCY/8)
31	Bit #9 for binary speed reference (value of MAXIMUM OUTPUT FREQUENCY/4)
32	Bit #10 for binary speed reference (value of MAXIMUM OUTPUT FREQUENCY/2)
33	no function (use terminal to connect wires)
34	Motor operated pot: increase frequency reference
35	Motor operated pot: decrease frequency reference
36	Motor operated pot: clear frequency reference
37	Three wire control: NO momentary start push button
38	Three wire control: NO momentary stop push button. Contact factory for information on how to realize stop with a NC contact.
40	Forward (open) or reverse (closed to "CC") command
41	Run (use in conjunction with 40 above)
42	Binary data write (use with 22-32 above). If no input terminal's function is set to "42", the drive responds immediately to binary references commanded by changing data bits. If one of the input terminal's function is set to "42", the drive responds to binary reference only when terminal is closed to "CC". Binary reference is lost when power is cycled.
43	emulate LOCAL/REMOTE key
51	Drive/bypass switching signal
53	give "RR" priority over "IV" and "RX"
54	give "IV" priority over "RR" and "RX"

## Parameter Explanations (cont'd)

Item 56, R, S1-S7 RESPONSE TIME - Use this function to adjust the time between an input terminal's connection to "CC" and its function's realization. A setting of "100" results in a delay of about 200 milliseconds.

Item 57, "F" INPUT TERMINAL RESPONSE TIME - Use this function to adjust the time between an input terminal's connection to "CC" and its function's realization. A setting of "100" results in a delay of about 200 milliseconds.

Item 58, "RES" INPUT TERMINAL RESPONSE TIME - Use this function to adjust the time between an input terminal's connection to "CC" and its function's realization. A setting of "100" results in a delay of about 200 milliseconds.

Item 59, "ST" INPUT TERMINAL RESPONSE TIME - Use this function to adjust the time between an input terminal's connection to "CC" and its function's realization. A setting of "100" results in a delay of about 200 milliseconds.

Item 60, "RCH" CONTACTS FUNCTION - Enter the code from the table on pages 9-11 and 9-12 to determine when drive will change the state of this dry output contact. Terminals "RCHA" and "RCHB" are either side of the contact.

Item 61, "RCH" CONTACTS DELAY TIME - sets the delay between the time the drive senses a desired condition and the time at which a change in "RCH" contact indicating this condition occurs. Maximum adjustment of "100" is approximately 200 milliseconds.

Item 62, "RCH" CONTACTS HOLD TIME - Example: Suppose drive is programmed to close "RCH" contact when it is outputting more than 30 Hz. When the drive's output frequency dips below 30 Hz, the contact will immediately open. Adjusting this parameter to "100" would keep the "RCH" contact closed (i.e. "RCHA" to "RCHB" shorted) for an additional 200 milliseconds after the drive outputted less than 30 Hz.

Item 63, "LOW" CONTACTS FUNCTION - See item 60 above.

Item 64, "LOW" CONTACTS DELAY TIME - See item 61 above.

Item 65, "LOW" CONTACTS HOLD TIME - See item 62 above.

Item 66, "FL" CONTACTS FUNCTION - See item 60 above. On terminal strip, normally open contact is between "FLA" and "FLC". Normally closed contact is between "FLB" and "FLC".

Item 67, "FL" CONTACTS DELAY TIME - See item 61 above.

Item 68, "FL" CONTACTS HOLD TIME - See item 62 above.

Item 69, "OUT" CONTACTS FUNCTION - See item 60 above. Available on INV3-COM-B and INV3-COM-D option boards (see page 11-6 for more information).

Item 70, "OUT" CONTACTS DELAY TIME - See item 61 above.

Item 71, "OUT" CONTACTS HOLD TIME - See item 62 above.



## Parameter Explanations (cont'd)

### Output Contacts' Functions

Value	Comments
0	Contact will close when drive is at or above Item 7, LOWER LIMIT FREQUENCY
1	Contact will close when drive is not at or above LOWER LIMIT FREQUENCY
2	Contacts will close when drive is at Item 6, UPPER LIMIT FREQUENCY
3	Contacts will close when drive is not at UPPER LIMIT FREQUENCY
4	Default for LOWA/LOWC terminals. Contact will close when drive is at or above speed in Item 72, LOW SPEED SIGNAL OUTPUT FREQUENCY
5	Contact will close when drive is not at or above LOW SPEED SIGNAL OUTPUT FREQUENCY
6	Default for RCHA/RCHC terminals. Contact closes when any accel or decel is complete.
7	Contact closes when any acceleration or deceleration is not complete.
8	Contact closes when drive is at or above Item 74, SPEED REACH MAXIMUM FREQUENCY during an accel or when drive is at or above Item 75, SPEED REACH MINIMUM FREQUENCY during a decel
9	Contact closes when drive is not at or above SPEED REACH MAXIMUM FREQUENCY during an accel or when drive is not at or above SPEED REACH MINIMUM FREQUENCY during a decel.
10	Default for FLA/FLB/FLC terminals. Contact closes when drive is faulted (ESTOP is not a fault)
11	Contact closes when drive is not faulted (ESTOP is not a fault)
12	Contact closes when drive is faulted on anything except EARTH FAULT or LOAD END OVERCURRENT (ESTOP is not a fault)
13	Contact closes when drive is faulted on EARTH FAULT or LOAD END OVERCURRENT
14	Contact closes when overcurrent stall is active (use as overcurrent pre-alarm). The stall current level is adjustable via Item 163 or Item 20 (see).
15	Contact closes when overcurrent stall is not active. The stall current level is adjustable via Item 163 or Item 20 (see).
16	Contact closes to signify inverter overload pre-alarm. Example of inverter overload: G3 is rated for 150% of rated current for 2 minutes. If drive is operated at 150% of rated current for one minute, the inverter overload is at 50%, or half of its overload current-time capability. The drive trips on overload at 100%. Inverter overload pre-alarm starts at 50%.
17	Contact closes to signify inverter is not in an overload pre-alarm. See explanation for value 16 above.
18	Contact closes to signify motor overload pre-alarm. Example of overload: G3 is rated for 150% of rated current for 2 minutes. If drive is operated at 150% of rated current for one minute, the inverter overload is at 50%, or half of its overload current-time capability. The drive trips on overload at 100%. Overload pre-alarm starts at 50%.
19	Contact closes to signify motor is not in an overload pre-alarm. See explanation for value 18 above.
20	Contact closes when heatsink reaches 84° C. Contact opens at 80° C after it has closed
21	Contact closes when heatsink is under 84° C. Contact closes at 80° C after it has opened
22	Contact closes when drive is displaying OVERVOLTAGE. See page 10-7.
23	Contact closes when drive is not displaying OVERVOLTAGE. See page 10-7.
24	Contact closes when drive is displaying DC BUS UNDERVOLTAGE. See page 10-7.
25	Contact closes when is not displaying DC BUS UNDERVOLTAGE. See page 10-7.
26	Contact closes when output current is at or greater than the current programmed into Item 167, LOW CURRENT DETECTION LEVEL for longer than the time programmed in Item 168, LOW CURRENT DETECTION TIME
27	Contact closes when output current is not at or greater than the current programmed into LOW CURRENT DETECTION LEVEL for longer than the time programmed in LOW CURRENT DETECTION TIME
28	Contact closes when torque current equals or exceeds the setting programmed into Item 171, OVERTORQUE TRIP LEVEL
29	Contact closes when torque current does not equal or exceed the setting programmed into OVERTORQUE TRIP LEVEL

*Output contact functions continued on next page*

## Parameter Explanations (cont'd)

### Output Contacts' Functions (con't)

Value	Comments
30	Contact closes when dynamic braking resistor is half way or more into its overload as calculated by the drive based upon the setting in Item 143, BRAKING RESISTOR VALUE and Item 144, BRAKING RESISTOR POWER RATING (GROUP:PROTECTION PARAMETERS). See explanation of overload for Value 16 on previous page.
31	Contact closes when dynamic braking resistor is less than half way into its overload as calculated by the drive based upon the settings in BRAKING RESISTOR VALUE and BRAKING RESISTOR POWER RATING. See explanation of overload for Value 17 on previous page.
32	Contact closes when drive is executing an ESTOP
33	Contact closes when drive is not executing an ESTOP
34	Contact closes when drive is executing a retry
35	Contact closes when the drive is not executing a retry
36	Contact closes when drive is running a Pattern Run
37	Contact closes when drive is not running a Pattern Run
38	Contact closes when the error signal calculated by the drive's PID equals or exceeds the value programmed into Item 251, PID DEVIATION UPPER LIMIT or Item 252, PID DEVIATION LOWER LIMIT (GROUP:FEEDBACK PARAMETERS)
39	Contact closes when the error signal calculated by the drive's PID does not equal or exceed the value programmed into PID DEVIATION UPPER LIMIT or PID DEVIATION LOWER LIMIT
40	Contact closes when drive is running at or above 0.01 Hz.
41	Contact closes when drive is not running at or above 0.01 Hz.
42	Contact closes when drive is faulted on a "severe" fault (not retryable) *
43	Contact closes when drive is not faulted on a "severe" fault *
44	Contact closes when drive is tripped on a retryable fault *
45	Contact closes when drive is not tripped on a retryable fault *
46	Auto-bypass control. Contact closes to energize coil of output contactor.
47	Opposite logic state of above
48	Auto-bypass control. Contact closes to energize coil of bypass contactor.
49	Opposite logic state of above
50	Contact closes when drive's cooling fan(s) is on.
51	Contact closes when drive's cooling fan(s) is not on.
52	Contact closes when drive is jogging
53	Contact closes when drive is not jogging
54	Contact closes when drive is not getting RUN/STOP command from the keypad
55	Contact closes when drive is getting RUN/STOP command from the keypad
56	Contact closes when drive run time is greater than or equal to time programmed into Item 174, CUMULATIVE RUN TIMER ALARM SETTING (GROUP:PROTECTION PARAMETERS)
57	Contact closes when drive run time is not greater than or equal to time programmed into CUMULATIVE RUN TIMER ALARM SETTING
58	Contact closes when drive trips on a COMMUNICATION ERROR
59	Contact closes when drive does not have a COMMUNICATION ERROR
60	Contact changes state when drive goes through 0.0 Hz to change direction. Contact is closed/open during forward/reverse run. Contact maintains current condition at 0.0 Hz when decel is complete after a stop command.
61	Contact changes state when drive goes through 0.0 Hz to change direction. Contact is open/closed during forward/reverse run. Contact maintains current condition at 0.0 Hz when decel is complete after a stop command.
62	Contact closes when drive has a run command and ST-CC is made
63	Contact closes when drive does not have a run command

\* Retryable faults include:

OVERCURRENT (ACCEL), OVERCURRENT (DECCEL), OVERCURRENT (RUN), DC OVERCURRENT (ACC), DC OVERCURRENT (DEC), DC OVERCURRENT (RUN), OVERVOLTAGE (ACCEL), OVERVOLTAGE (DECCEL), OVERVOLTAGE (RUN), OVERHEAT, MOTOR OVERLOAD, INVERTER OVERLOAD, DBR OVERLOAD TRIP



## Parameter Explanations (cont'd)

Item 72, **LOW SPEED SIGNAL OUTPUT FREQUENCY** - Use this parameter to set the frequency above which one of the drive's output contacts (RCHA-RCHC, etc) changes state. See Item 60, 63, and 66.

Item 73, **ACC/DEC COMPLETE DETECT BAND** - If one of the output contacts' function is set to "6" (accel/decel complete), use this parameter to operate the contact when the output frequency is within this bandwidth (minus during accel, plus during decel) of the frequency command.

Item 74, **SPEED REACH MAXIMUM FREQUENCY** - Use this parameter to set the output frequency at which one of the drive's output contacts (RCHA-RCHC, etc.) changes state during an acceleration. See Items 60, 63, and 66.

Item 75, **SPEED REACH MINIMUM FREQUENCY** - Use this parameter to set the output frequency at which one of the drive's output contacts (RCHA-RCHC, etc.) changes state during a deceleration. See Items 60, 63, and 66.

Item 76, **COMMERCIAL POWER/INVERTER SWITCHING OUTPUT** - On appropriately equipped drives, use this parameter to determine when the G3's bypass circuitry is activated:

- 1: Motor runs on bypass when drive trips
- 2: Motor runs on bypass when a signal is given
- 3: Both of the above

Contact your Toshiba distributor for information on how to program and wire a G3 for this function.

Item 77, **COMMERCIAL POWER/INVERTER SWITCHING FREQUENCY** - On appropriately equipped drives, use this parameter to determine the drive output frequency reached before the G3's bypass circuitry is activated. Contact your Toshiba distributor for information on how to program and wire a G3 for this function.

Item 78, **"FP" OUTPUT TERMINAL PULSE FREQUENCY** - Use this parameter to set the number of pulses per output Hz.

Item 79, **RR INPUT SPECIAL FUNCTION SELECT** - Use this parameter to change the function of the 0-10 volt signal applied to the "RR" terminal:

- 0: Standard (speed reference)
  - 1: Scale **MAXIMUM OUTPUT FREQUENCY**. Minimum 30 Hz
  - 2: Adjust multiplier on accel/decel times. Zero volts sets the multiplier to 1, 10 volts sets the multiplier to 10.
  - 3: Adjust voltage boost. Zero volts sets voltage boost to 0%. 10 volts set the voltage boost to its programmed value.
  - 4: Current limit. Ten volts sets current limit to 150%. Contact your Toshiba distributor for information on how to Torque Current limit.

Suggestion: set one of the monitors (Items 289-292) to a value of "14" (RR input value) to see effective **MAXIMUM OUTPUT FREQUENCY**, accel/decel multiplier, effective voltage boost, or effective **STALL PROTECTION CURRENT LEVEL**.

Item 80, **FREQUENCY PRIORITY SELECTION #1** - use this parameter to give one of the drive's frequency setting signals priority over another. Only when the signal set here goes to zero will the drive follow the signal set in Item 81. If the signal selected here becomes non-zero, the drive will follow it and ignore the signal selected in Item 81. Set this parameter to "5" when using MOP control or inputting a binary reference via the drive's terminal strip. Preset speeds have priority over "RR" and "RX".

Item 81, **FREQUENCY PRIORITY SELECTION #2** - use this parameter to give one of the drive's frequency setting signals priority over another. Only when the signal set in Item 80 goes to zero will the drive follow the signal set here. If the signal selected in Item 80 becomes non-zero, the drive will follow it and ignore the signal selected here.

**Parameter Explanations (cont'd)**

Item 82, **ANALOG INPUT FILTER** - Use this parameter to set the amount of filtering applied to the drive's current/voltage frequency reference to dampen noise or resonance problems. "0" is no filtering and "3" is maximum filtering.

Item 83, **RR INPUT SELECTION** - Use this parameter to allow adjustment of the RR reference's bias and gain. Items 84 and 85 define one point on a % input reference vs. output Hz graph; Items 86 and 87 define another. The drive varies its output frequency as its input changes according to a line connecting these points. See graph below. With default programming, drive outputs 40 Hz with 5 volts on the "RR" terminal.

Item 84, **RR REFERENCE POINT #1** - Use this parameter to set a percentage of reference.

Item 85, **RR REF POINT #1 FREQUENCY** - Use this parameter to set the desired drive output Hz when its reference has the value set in Item 84 above.

Item 86, **RR REFERENCE POINT #2** - Use this parameter to set a percentage of reference. The "RR" terminal's range is 0-10 volts, so the factory default of 100% corresponds to 10 volts.

Item 87, **RR REF POINT #2 FREQUENCY** - Use this parameter to set the desired drive output Hz when its reference has the value set in Item 86 above.

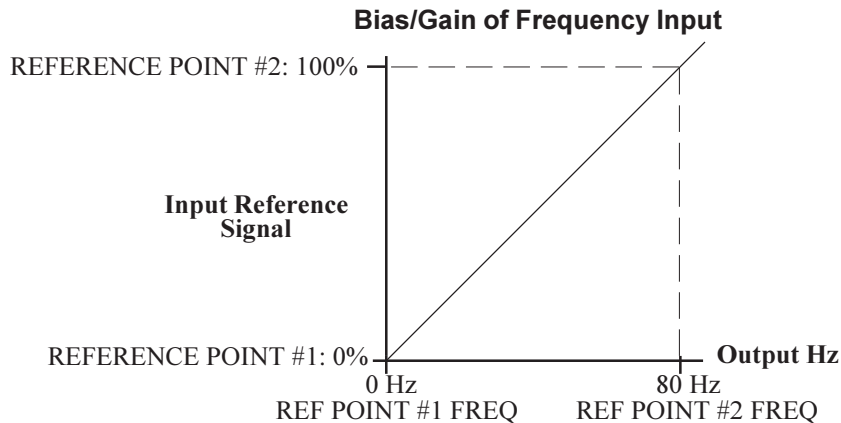

Items 88-92, **IV TERMINAL STANDARD OR ADJUSTABLE** - Use these parameters to allow adjustment of the "IV" reference's bias and gain. See explanation for Items 83-87 above. With dipswitch in "I" position, drive considers 100% reference = 20 mA (20% would be 4 mA). With dipswitch in "V" position, 100% reference = 10 volts. See page 5-3 for dipswitch location.

Items 93-97, **RX TERMINAL STANDARD OR ADJUSTABLE** - Use these parameters to allow adjustment of the "RX" reference's bias and gain. See explanation for Items 83-87 above. With dipswitch in "5" position, drive considers 100% reference = 5 volts. With dipswitch in "10" position, 100% reference = 10 volts. See page 5-3 for dipswitch location. Notice that the "RX" reference can be positive or negative, and can represent a positive or negative frequency (direction change).

Items 98-102, **PG TERMINAL STANDARD OR ADJUSTABLE** - Use these parameters to allow adjustment of the "PG" reference's bias and gain. See explanation for Items 83-87 above. PG input is available on option cards INV3-COM-B and INV3-COM-D. Notice that the PG reference can be positive or negative, and can represent a positive or negative frequency (direction change).

Items 103-107, **BINARY INPUT STANDARD OR ADJUSTABLE** - Use these parameters to allow adjustment of a binary reference's bias and gain. See explanation for Items 83-87 above. Notice that the binary reference can represent a positive or negative frequency (direction change). These bias/gain adjustments apply to terminals programmed with values 22-32 on page 9-9.

## Parameter Explanations (cont'd)

Item 108, JOG RUN FREQUENCY - Use this parameter to set the run frequency during a jog. An accel time of zero is used, so low jog frequencies of 5 Hz or less and light loads are recommended. For information on jogging from the keypad, see page 7-1. For information on how to jog from the terminal strip, see pages 8-9 and 9-9. During a jog, low speed, speed reach, and PID, functions do not operate.

Item 109, JOG STOP METHOD - This parameter determines the way a jog is stopped. If DC Injection is selected, also adjust Item 146, DC INJECTION STARTING FREQUENCY, Item 147, DC INJECTION CURRENT, and Item 148, DC INJECTION TIME. Jog is stopped by releasing the "RUN" key (when in panel control), and by opening "F"- "CC" or "R"- "CC" (when in remote control).

Item 110, PRESET SPEED SELECTION - Enter the total number of preset speeds to be accessed.

Item 111, PRESET SPEED MODE ACTIVATION - If this parameter is set to "1", the corresponding preset speeds' acc/dec time selection, volts per hertz pattern selection, and direction is determined by the setting of PRESET SPEED #<1,2,3,4,5,6,7,8,9,10,11,12,13,14, or 15> OPERATING MODE (Items 113, 115, 117, etc.). Directions commanded by closing "F"- "CC" or "R"- "CC" are effectively ignored. If Item 111 is set to "0", the direction is determined by the terminal strip.

Items 112, 114, 116, 118, 120, 122, 124, 126, 128, 130, 132, 134, 136, 138, 140, PRESET SPEED #<1,2,3,4,5,6,7,8,9,10,11,12,13,14, or 15> FREQUENCY - Use this parameter to set preset speed frequencies.

Items 113, 115, 117, 119, 121, 123, 125, 127, 129, 131, 133, 135, 137, 139, 141, PRESET SPEED #<1,2,3,4,5,6,7,8,9,10,11,12,13,14, or 15> OPERATING MODE - Use this parameter to associate a direction and ACCELERATION TIME #1 / DECELERATION TIME #1 or ACCELERATION TIME #2 / DECELERATION TIME #2 with a preset speed. See Item 111.

With default programming, the "S1", "S2", "S3", and "S4" terminals (see Items 45-48) are preset speed selections via a binary implementation. Some examples:

"S4" to "CC"	"S3" to "CC"	"S2" to "CC"	"S1" to "CC"	Commanded Preset Speed #
open	open	open	close	1
open	open	closed	closed	3
closed	closed	open	open	12
open	closed	open	closed	5
closed	closed	closed	closed	15
closed	open	open	closed	9
closed	open	closed	open	10

A "F"- "CC" or "R"- "CC" closure is necessary to initiate a preset speed run.

Item 142, DYNAMIC BRAKING SELECTION - Adjust this parameter when attaching a dynamic braking resistor to the drive for increased stopping ability. A setting of "1" affords no protection for the resistor (use for over-sized wattages, or for externally-protected resistors). A setting of "2" invokes the drive's braking resistor protection (drive will trip on DB RESISTOR OVERLOAD if resistor is overloaded). See Items 143 and 144. For optimum use of the dynamic braking resistor, set Item 145, OVERVOLTAGE STALL PROTECTION to "1", "off".

Item 143, BRAKING RESISTOR VALUE - Enter ohm value of resistor. See page 9-16 for recommended DBR sizing.

Item 144, BRAKING RESISTOR POWER RATING - Enter kilowatt value of resistor. See page 9-16 for recommended DBR sizing.

## Parameter Explanations (cont'd)

### DYNAMIC BRAKING

When a motor is mechanically forced to spin faster than the output frequency of the drive, the motor acts as a generator. This regenerated energy forces current to flow into the drive's DC bus. The bus capacitors will absorb some of the regenerative energy by charging and raising the DC bus voltage. At high bus voltages, the drive can be programmed to fire the IGBT7 dynamic braking transistor. This prevents a common drive fault, `DC BUS OVERVOLTAGE`. The dynamic braking resistor, attached by the user to the "PA" and "PB" terminals, dissipates the bus energy as heat when the IGBT7 fires. Two resistor values are of concern: resistance (ohms) and power (watts). Insufficient resistance may lead to IGBT7 damage; too low of a wattage may result in braking resistor damage from overheating.

#### HEAVY DUTY RESISTORS

WATTS: 300 watts per drive HP

G3 Model	H.D. Ohms	G3 Model	H.D. Ohms
2010	60	4015	145
2015	60	4025	125
2025	50	4035	135
2035	35	4055	108
2055	28	4080	65
2080	20	4110	60
2110	12	4160	38
2160	7.0	4220	30
2220	6.0	4270	22
2270	5.0	4330	20
2330	4.0	4400	14
6060	300	4500	8.0
6120	150	4600	7.0
6160	100	4750	7.0
6220	75	410K	5.5
6270	60	412K	5.0
6330	50	415K	4.0
6400	37	420K	3.0
6500	30	425K	2.4
6600	25	430K	2.0
6700	20	435K	2.0
610K	15		
612K	12		
615K	10		
620K	7.0		
625K	6.0		

#### LIGHT DUTY RESISTORS

WATTS: 60 watts per drive HP

G3 Model	L.D. Ohms	G3 Model	L.D. Ohms
2010	600	4015	1800
2015	450	4025	900
2025	225	4035	600
2035	150	4055	360
2055	90	4080	240
2080	61	4110	180
2110	45	4160	120
2160	30	4220	90
2220	23	4270	70
2270	18	4330	61
2330	15	4400	45
6060	750	4500	36
6120	375	4600	30
6160	250	4750	24
6220	190	410K	18
6270	150	412K	15
6330	125	415K	12
6400	94	420K	9.0
6500	75	425K	7.0
6600	63	430K	6.0
6700	50	435K	6.0
610K	38		
612K	30		
615K	25		
620K	19		
625K	15		

Contact your Toshiba distributor for dynamic braking resistor part numbers and information.

Item 145, `OVERVOLTAGE STALL PROTECTION` - This function is turned on as a default setting. Overvoltage stall protection causes the drive to automatically extend the decel time when the DC bus voltage increases due to regeneration. The value stored in `DECELERATION TIME #1 / DECELERATION TIME #2` is not changed. The drive may still trip on overvoltage if the decel time is very small.

## Parameter Explanations (cont'd)

Item 146, DC INJECTION STARTING FREQUENCY - Use this parameter to set the frequency at which DC injection begins. DC injection can be initiated remotely by programming one of the input terminals appropriately (see Items 44-54 and page 9-9).

Item 147, DC INJECTION CURRENT - sets the current level to be employed during DC injection. Amount can be in % of drive rating or in amps (set by Item 296).

Item 148, DC INJECTION TIME - sets the number of seconds DC is applied to the motor.

Drive will DC inject approximately 60% FLA continuously, 80% for 100 seconds, and 100% for 2 seconds without an INVERTER OVERLOAD trip.

DC injection is active when the drive's output frequency is below DC INJECTION START FREQUENCY and the drive has a STOP command or a zero reference. DC injection is also active when the drive's output frequency is below Item 32, END FREQUENCY.

Item 149, FWD/REV DC INJECTION PRIORITY CONTROL - When drive is running in forward direction and is given a reverse reference, this parameter determines whether or not DC injection is active between DC INJECTION STARTING FREQUENCY and 0 Hz. Also, a setting of "1" gives DC injection priority over a new run command. With a setting of "0", a new run command has priority over DC injection.

Item 150, MOTOR SHAFT STATIONARY CONTROL - This parameter enables a continuous DC injection into a stopped motor. Amps are set by DC INJECTION CURRENT / 2. Motor shaft stationary control starts after DC injection and continues until "ST"- "CC" is opened, power is turned off, drive emergency stops, or parameter is changed.

Item 151, EMERGENCY STOP SELECTION - This parameter determines ESTOP method.

Item 152, EMERGENCY OFF DC INJECTION TIME - This is a unique DC injection time for ESTOPs.

Item 153, NUMBER OF RETRY ATTEMPTS - The G3 can be programmed to restart after a fault occurs. This parameter sets the number of retry attempts. Speed search is automatically on during retry. Retry will not function if Item 172, FAULT TRIP EEPROM SAVE ENABLE is on.

Item 154, TIME BETWEEN RETRY ATTEMPTS - Adjust this parameter to set the number of seconds between retry attempts.



## CAUTION

**Make sure that workers are not exposed to danger from equipment suddenly re-starting when a fault occurs and a retry selection option other than "0" has been selected.**

Item 155, REGENERATION POWER RIDE THROUGH CONTROL - G3 models 2080-2110 and 4080-4270 take control power from the DC bus; enabling this function allows use of regeneration energy from the motor to maintain control during a brown-out. Accel/decel times may need to be adjusted to avoid overvoltage trips. **Always confirm operation.**

Item 156, REGENERATION POWER RIDE THROUGH TIME - Use this parameter to limit ride-through time (effective only if there is sufficient regen energy).

Item 157, AUTO-RESTART (MOTOR SPEED SEARCH) - This parameter enables the drive's ability to catch a spinning motor:

- 0: Speed search off
- 1: Drive performs speed search after a power glitch
- 2: Drive performs speed search after "ST"- "CC" is made
- 3: Both 1 and 2 above

A drive with a forward direction command will catch a reversing motor.

## Parameter Explanations (cont'd)

### DRIVE AND MOTOR OVERLOADS

The G3 features separate overload curves for itself and the motor. All G3s can output 110% of their rated current continuously; current levels above 110% are considered *overload*. The drive overload is fixed: 100 HP and smaller G3s' overload is 150% of their rated current for 120 seconds; 125 HP and larger G3s' overload is 130% for 120 seconds. The motor's overload curve is defined by Items 158, 159, 160, and output frequency:

Item 158, **ELECTRONIC THERMAL PROTECT LEVEL 1** - use this parameter to scale the motor overload protection to a specific motor's amp rating. Can be entered in percent or in amps, depending on the setting of Item 296, **CURRENT UNITS SELECTION**. For percent setting, divide motor full load amps by drive full load amps and multiply by 100.

Item 159, **OVERLOAD REDUCTION START FREQUENCY** - The motor overload protection provided by the drive is speed-sensitive by default. With default setting, a G3 at 115% of the current set by **ELECTRONIC THERMAL PROTECT LEVEL 1** will trip on **MOTOR OVERLOAD** sooner at 15 Hz than at 60 Hz. Users who have allowed for reduced motor cooling at low speeds can reduce this parameter to get more overload capability. The drive's overload protection is speed sensitive at frequencies below the value entered here.

Item 160, **MOTOR 150% OVERLOAD TIME LIMIT** - This parameter sets the time the drive will output 150% of the current set by Item 158, **ELECTRONIC THERMAL PROTECTION LEVEL #1** before tripping on **MOTOR OVERLOAD**.

Item 161, **OVERLOAD SELECTION** - This parameter adjusts the overload protection scheme.

0: Standard

1: Soft stall on. Soft stall reduces output frequency only when the drive is in its overload region. Soft stall helps prevent drive from tripping on **INVERTER OVERLOAD**.

2: Motor overload trip off.

3: Soft stall on and motor overload trip off.

Motor overload sensing is "on" unless "2" or "3" is selected.

**INVERTER OVERLOAD** cooling time is approximately one minute after trip

**MOTOR OVERLOAD** cooling time is approximately five minutes after trip

**DBR OVERLOAD** cooling time is approximately thirty seconds after trip

Item 162, **STALL PROTECTION ENABLE** - Drive current limits when stall is turned "on".

Item 163, **STALL PROTECTION LEVEL** - Drive will reduce its output frequency and voltage automatically to limit output current to the value programmed here.

Item 164, **UNDERVOLTAGE TRIP SELECTION** - The drive can be programmed to **UNDERVOLTAGE TRIP** when the DC bus voltage is under a factory-set value by programming a "1" here. See Item 165 also. An undervoltage alarm is available in the form of a drive output contact change; see Items 60, 63, or 66 and setting values 24/25 on page 9-11.

Item 165, **UNDERVOLTAGE DETECT TIME** - The DC bus must be low for at least the time entered here before the drive faults on **UNDERVOLTAGE TRIP**.

Item 166, **LOW CURRENT DETECT SELECTION** - The drive can be programmed to **LOW CURRENT TRIP** when its output current is below the value programmed in Item 167 for at least the time programmed in Item 168. Enter a "1" here to enable the low current detection. A low current alarm is available in the form of a drive output contact change; see Items 60,63, or 66 and setting values 26/27 on page 9-11.



## Parameter Explanations (cont'd)

Item 167, **LOW CURRENT DETECT LEVEL** - Enter the current amount (in % or amps depending on setting of Item 296) below which the drive will trip and/or close an appropriately-programmed output contact.

Item 168, **LOW CURRENT DETECTION TIME** - Enter the time the output current must be below the amount set in Item 167 before the drive trips and/or closes an appropriately-programmed output contact.

Item 169, **OUTPUT SHORT-CIRCUIT DETECTION SELECT** - To protect itself, the drive does an output short-circuit check every time a run is initiated. This parameter changes the short-circuit check:

0: Standard setting

1: When a low impedance motor is used, this setting desensitizes the short-circuit check, reducing nuisance trips.

2: This setting programs the drive to perform the check at power up only.

3: Combination of 1 and 2 above.

Do not operate the drive on a motor with power factor correction capacitors.

Item 170, **OVERTORQUE TRIP SELECTION** - Enter a "1" here to program the drive to fault **OVERTORQUE TRIP** based on on the torque current amount. See Item 171.

Item 171, **OVERTORQUE TRIP LEVEL** - Enter the torque current (in % or amps depending on the setting of Item 296, **CURRENT UNITS SELECTION**) at which the drive trips and/or closes an appropriately-programmed output contact (see Items 60,63, or 66 and setting values 28/29 on page 9-11).

Item 172, **FAULT TRIP SAVING** - This parameter determines the effect of cycling power on a faulted drive:

0: Fault and fault data cleared when drive powers up.

1: Drive powers up in tripped state (drive display remains in faulted state, but fault data and fault contact are not maintained).

The setting of Item 153, **NUMBER OF RETRY ATTEMPTS**, is ignored by the drive when Item 172 is set to "1".

Item 173, **COOLING FAN CONTROL SELECTION** - This parameter determines if the drive's fan is thermostatically-controlled or if it runs continuously.

Item 174, **CUMULATIVE RUN TIMER ALARM SETTING** - One of the drive's output contacts can be programmed to change state based upon the time entered here. See Items 60,63, or 66 and setting values 56/57 on page 9-12. ".01" is one hour.

## PATTERN RUN

The G3 has a feature called pattern run that emulates a low-level PLC. During a pattern run, the drive follows a *pattern group* by running at the user's preset speeds for desired amounts of time in desired directions with desired accel/decel times for a defined number of cycles. The G3 has 15 preset speeds, any of which can be assigned to be speeds zero through seven in a pattern group. The G3 can hold up to four separate pattern groups, any of which can be remotely selected to run.

Item 175, **PATTERN RUN SELECTION** - This parameter enables pattern run. When stopping/starting drive from panel, pattern run takes priority over the keypad's frequency reference.

Item 176, **PATTERN RUN CONTINUE MODE** - This parameter determines if a pattern group is continued after a pattern run is stopped and restarted:

0: Pattern group starts over with its first speed

1: Pattern resumes at the time of and with the speed at interruption

## Parameter Explanations (cont'd)

Items 177, 186, 195, and 204, PATTERN GROUP #<1,2,3, or 4> SPEED #0 - This parameter determines which preset speed (preset speeds 1 through 15 programmed in Items 110-141) is the first speed in the pattern group. Unlike the other speeds #1 - #7, speed #0 is not repeated when PATTERN GROUP #<1,2,3, or 4> NUMBER OF CYCLES is greater than one. Set this parameter to "0" to skip this speed.

Items 178, 187, 196, 205, PATTERN GROUP #<1,2,3, or 4> SPEED #1 - This parameter determines which preset speed (preset speeds 1 through 15 programmed in Items 110-141) is the next speed in the pattern group. Speed #1 can be but does not have to be Preset Speed #1.

Items 179, 188, 197, 206, PATTERN GROUP #<1,2,3, or 4> SPEED #2 - This parameter determines which preset speed (preset speeds 1 through 15 programmed in Items 110-141) is the next speed in the pattern group. Speed #2 can be but does not have to be Preset Speed #2.

Items 180, 189, 198, 207, PATTERN GROUP #<1,2,3, or 4> SPEED #3 - This parameter determines which preset speed (preset speeds 1 through 15 programmed in Items 110-141) is the next speed in the pattern group. Speed #3 can be but does not have to be Preset Speed #3.

Items 181, 190, 199, 208, PATTERN GROUP #<1,2,3, or 4> SPEED #4 - This parameter determines which preset speed (preset speeds 1 through 15 programmed in Items 110-141) is the next speed in the pattern group. Speed #4 can be but does not have to be Preset Speed #4.

Items 182, 191, 200, 209, PATTERN GROUP #<1,2,3, or 4> SPEED #5 - This parameter determines which preset speed (preset speeds 1 through 15 programmed in Items 110-141) is the next speed in the pattern group. Speed #5 can be but does not have to be Preset Speed #5.

Items 183, 192, 201, 210, PATTERN GROUP #<1,2,3, or 4> SPEED #6 - This parameter determines which preset speed (preset speeds 1 through 15 programmed in Items 110-141) is the next speed in the pattern group. Speed #6 can be but does not have to be Preset Speed #6.

Items 184, 193, 202, 211, PATTERN GROUP #<1,2,3, or 4> SPEED #7 - This parameter determines which preset speed (preset speeds 1 through 15 programmed in Items 110-141) is the next speed in the pattern group. Speed #7 can be but does not have to be Preset Speed #7.

Items 185, 194, 203, 212, PATTERN GROUP #<1,2,3, or 4> NUMBER OF CYCLES - This parameter determines how many times the pattern group made up of speeds #1 through #7 entered in the above parameters will be repeated.

Items 213, 215, 217, 219, 221, 223, 225, 227, 229, 231, 233, 235, 237, 239, and 241, SPEED #<1,2,3,4,5,6,7,8,9,10,11,12,13,14, or 15> CONTINUE MODE. This parameter affects the timing of the speeds in a pattern group:

0: Preset speed's time is counted in *seconds* from the beginning of the run (accel/decel time is included in the time entered in the following parameter, SPEED

#<1,2,3,4,5,6,7,8,9,10,11,12,13,14, or 15> DRIVE TIME

1: Preset speed's time is counted in *minutes* from the beginning of the run (accel/decel time is included in the time entered in the following parameter, SPEED

#<1,2,3,4,5,6,7,8,9,10,11,12,13,14, or 15> DRIVE TIME

2: Preset speed's time is counted in *seconds* after preset speed is reached (accel/decel time is not included in the time entered in the following parameter, SPEED

#<1,2,3,4,5,6,7,8,9,10,11,12,13,14, or 15> DRIVE TIME

3: Preset speed's time is counted in *minutes* after preset speed is reached (accel/decel time is not included in the time entered in the following parameter, SPEED

#<1,2,3,4,5,6,7,8,9,10,11,12,13,14, or 15> DRIVE TIME

4: Non-stop (stop by breaking ST-CC or F-CC or R-CC).

5: Drive waits for step command to change speeds. See Items 45-54 and setting value 19 on page 9-9.



## Parameter Explanations (cont'd)

Items 214, 216, 218, 220, 222, 224, 226, 228, 230, 232, 234, 236, 238, 240, and 242, `SPEED NUMBER <1,2,3,4,5,6,7,8,9,10,11,12,13,14, or 15> DRIVE TIME` - This parameter determines the amount of time associated with each *preset* speed. The time unit (minutes/seconds) is determined by the preceding parameter.

Item 243, `FEEDBACK CONTROL SELECTION` - This parameter programs the drive to operate in PID mode (maintain a process variable such as pressure), speed feedback, or in normal mode.

Item 244, `FEEDBACK INPUT SIGNAL SELECTION` - This parameter programs the drive to accept feedback at one of many possible inputs:

- 1: "RR" terminal
- 2: "IV" terminal
- 3: "RX" terminal
- 4: Pulse generator input (on option board INV3-COM-B or INV3-COM-D)
- 5: RS232 port
- 6: RS485 port or 12 bit input (on option board INV3-COM-A, INV3-COM-C or G3-VF5X-4526A)
- 7: Binary input (via input terminals programmed appropriately - see Items 45-54 and setting values 22-32 on page 9-9).

Item 245, `PROPORTIONAL GAIN` - The larger the value here, the quicker the drive responds to changes in feedback. Contact Houston for the PID application guideline. `READ/WRITE` does not have to be pressed to make the value entered here effective.

Item 246, `INTEGRAL GAIN` - Also known as reset, this parameter is actually a time. The smaller the value here, the more pronounced the effect of the integral function. Contact Houston for the PID application guideline. `READ/WRITE` does not have to be pressed to make the value entered here effective.

Item 247, `ANTI-HUNTING GAIN` - Also known as differential gain or rate, this parameter is actually a time. The larger the value here, the more pronounced the effect of the differential function. Contact Houston for the PID application guideline. `READ/WRITE` does not have to be pressed to make the value entered here effective.

Item 248, `LAG TIME CONSTANT` - This parameter effects drive reaction time to change in feedback value. Decrease this setting to improve drive response.

Item 249, `PID LOWER LIMIT FREQUENCY` - When PID is active, Item 7, `LOWER LIMIT FREQUENCY` is not effective. This parameter is the lower limit when PID is active. Some drives have a version of keypad ROM that does not contain this parameter (version 100). If drive cannot display this parameter, see section 7.4 about identifying keypad ROM version. Keypad ROM versions 110 and 121 contain Item 249.

Item 250, `PID DEVIATION LIMIT SELECTION` - The amount of correction calculated by the drive can be limited to control possible system oscillations. Place a "1" here to PID deviation limit.

Item 251, `PID DEVIATION UPPER LIMIT` - The amount of correction calculated by the drive is limited to the value entered here, expressed in terms of percent of Item 1, `MAXIMUM OUTPUT FREQUENCY`.

Item 252, `PID DEVIATION LOWER LIMIT` - The amount of correction calculated by the drive is limited to the value entered here, expressed in terms of percent of Item 1, `MAXIMUM OUTPUT FREQUENCY`.

Item 253, `PG INPUT: NUMBER OF PULSES` - When an encoder and PG option board (INV3-COM-B or INV3-COM-D) is being used for closed loop speed control, enter pulses per revolution. When using option board to follow a pulse reference, enter number of pulses that correspond to a frequency command of one hertz. See the Extended Terminal Block Option Manual for more information.

## Parameter Explanations (cont'd)

Item 254, PG INPUT: NUMBER OF PHASES - Use this parameter to select either one or two phase encoder feedback. See the Extended Terminal Block Option Manual for more information.

Item 255, DROOPING CONTROL ENABLE - Use this parameter to enable the G3's load share function, which continuously stalls based on load. This parameter can be changed while the drive is at a non-zero output frequency, but the change does not go into effect until drive is stopped.

Item 256, DROOPING CONTROL AMOUNT - Use this parameter to set the maximum amount of droop (in percent of Item 1, MAXIMUM OUTPUT FREQUENCY).

When drooping, Output Frequency = Reference Frequency - Droop

Droop = MAXIMUM OUTPUT FREQUENCY x DROOPING CONTROL AMOUNT x Torque Ratio

Torque Ratio (maximum value of 2.0) = operating torque / rated torque

Item 257, OVERRIDE CONTROL SELECTION - Use this parameter to create a "trim pot". The "trim pot" function allows a user to uniquely adjust the speed of a drive that is receiving a master reference. The bias/gain of these inputs determines their effect on the master reference (see Items 84-107). Select which one of the G3's frequency references will serve as the trim source:

0: none

1: "RR" terminal

2: "IV" terminal

3: "RX" terminal (+/- trim possible)

4: Pulse generator input on option card INV3-COM-B or INV3-COM-D (+/- trim possible)

5: G3 keypad

6: RS485 input or 12-bit input on option cards INV3-COM-A, INV3-COM-C, or G3-VF5X-4526A

7: Trim source with multiplier. See Items 258 and 259 below.

Item 258, OVERRIDE MULTIPLIER INPUT SELECTION - When used with a multiplier, the following inputs' bias and gain do not determine their effect on the master reference. Select which of the following trim sources will be used with the multiplier:

0: Frequency reference

1: "RR" terminal

2: "IV" terminal

3: "RX" terminal

4: RS485 input or 12-bit input on option cards INV3-COM-A, INV3-COM-C, or G3-VF5X-4526A

Item 259, OVERRIDE CHANGE MULTIPLIER - When Item 258 is set to "0", this parameter sets the percent of reference to be added/subtracted to/from the reference. When Item 258 is set to "1", "2", "3", or "4", the value entered here determines the maximum range of trim in terms of percentage of reference. This maximum range of trim includes both positive and negative trim bandwidths. Any amount of trim up to this maximum is available by changing the trim terminal's input. Maximum negative trim is achieved with minimum input on trim terminal. Maximum positive trim is achieved with maximum input on trim terminal.

Example: Suppose Item 258 is set to "1" (RR trim), Item 259 is set to "25%", and a 4-20 mA reference into the "IV" terminal is commanding 40 Hz. When the "RR" input is 0 volts, the drive outputs 35 Hz ( $40 - ((40 \times 0.25)/2)$ ). When the "RR" input is adjusted to 10 volts, the drive outputs 45 Hz ( $40 + ((40 \times 0.25)/2)$ ).

Item 260, RS232 BAUD RATE - sets baud rate. Cycle power after changing this parameter.

Item 261, NUMBER OF DATA BITS - sets the word length. Cycle power after changing.

Item 262, PARITY SETTING - sets the parity. Cycle power after changing this parameter.

Item 263, INVERTER ID NUMBER - assigns unique ID to drive for use on RS485 net. Cycle power after changing this parameter.

## Parameter Explanations (cont'd)

Item 264, **COMMUNICATION SELECTION** – Use this parameter to select type of communication:

- 0: None
- 1: RS485 port on option boards INV3-COM-A, INV3-COM-C, or INV3-COM-B
- 2: Toshiba TOSLINE F10 (twisted pair). Contact your Toshiba distributor for more information
- 3: Toshiba TOSLINE S20 (fiber optic). Contact your Toshiba distributor for more information.
- 4: 12 bit binary reference using option card G3-VF5X-4526A
- 5: Three digit BCD input on card G3-VF5X-4526A ( 0.1 Hz resolution )
- 6: Three digit BCD input on card G3-VF5X-4526A ( 1.0 Hz resolution )

Cycle power after changing this parameter.

Item 265, **MASTER/SLAVE SELECTION** – This parameter defines the drive's role in the master/follower scenario. A value of "1" entered here will make followers follow the frequency command the master is receiving (master may be stopped while the followers run). A value of "2" entered here will make the followers run according to the master's output frequency. Cycle power after changing this parameter.

Item 266, **RS485 BAUD RATE** – In conjunction with jumpers J1 and J2 on the RS485 option board used, this parameter sets the *RS485 baud rate* as follows:

Position of		Setting of Item 266	
J1	J2	0	1
off	off	9600	38400
on	off	4800	19200
off	on	2400	9600
on	on	1200	4800

INV3-COM-A and INV3-COM-B cards' max baud is 19200.

INV3-COM-C card's max baud is 38400.

Cycle power after changing this parameter.

Item 267, **TOSLINE F10/S20 COMMAND INPUT** – determines if drive accepts run/stop and/or frequency commands from TOSLINE. Contact PLC marketing for more information. Cycle power after changing this parameter.

Item 268, **TOSLINE F10/S20 MONITOR OUTPUT** – determines the drive operating data to be communicated. Contact PLC marketing for more information. Cycle power after changing this parameter.

Item 269, **TOSLINE F10/S20 COMM ERROR MODE** – When set to a value of "0", a zero speed command is commenced in the event of an error. A value of "1" the data prior to the error is held. Cycle power after changing this parameter.

Items 270-274, **RS485/12-BIT BINARY BIAS, GAIN** – use these parameters to allow adjustment of the RS485 or 12 bit reference's bias and gain. See explanation for Items 83-87 above. Follower's 100% reference is master's Item 1, **MAXIMUM OUTPUT FREQUENCY**. RS485 input is available on option cards INV3-COM-A, INV3-COM-B, and INV3-COM-C. 12 bit binary input is available on option card G3-VF5X-4526A. Cycle power after changing this parameter.

Item 275, **FM TERMINAL FUNCTION SELECTION** – This parameter determines the drive operating variable associated with the 0-1 mA/4-20 mA signal from the "FM" and "CC" terminals. The "FM" output is user-selected as 0-1 mA or 4-20 mA by setting JP3 (to the left of the terminal strip) in the appropriate position (see page 5-2). *Do not make connections to this terminal with the drive powered.*

(continued next page)

## Parameter Explanations (cont'd)

Item 275, FM TERMINAL FUNCTION SELECTION (con't) - Choices for "FM" terminal's signal's function:

- 0: (default for "FM"). Pre-compensation reference frequency. This is the drive's internal frequency command and is affected by acc/dec and PID and droop (same as the actual output frequency displayed on the drive's keypad).
- 1: Post-compensation output frequency may be higher than frequency command (drive overspeeds to compensate for slip in vector control).
- 2: Frequency command. Use for master/follower. Not affected by stopping or accel/decel.
- 3: (default for "AM"). Output current.  $(\text{output amps})^2 = (\text{torque amps})^2 + (\text{excitation amps})^2$
- 4: DC bus voltage
- 5: Output voltage
- 6: Torque current.  $(\text{output current})^2 = (\text{torque current})^2 + (\text{excitation current})^2$
- 7: Excitation current.  $(\text{output current})^2 = (\text{torque current})^2 + (\text{excitation current})^2$
- 8: PID feedback value. This is the frequency represented by the feedback signal
- 9: Motor overload ratio. Example: G3 is rated for 150% FLA for 2 minutes. If G3 runs at 150% for 1 minute, this output will be 50%. Drive trips when ration hits 100%.
- 10: Inverter overload ratio. See example for selection 9 above.
- 11: Dynamic braking resistor overload ratio. See example for selection 9 above.
- 12: Input power (watts)
- 13: Output power (watts)
- 14: Meter calibration setting
- 15: Peak output current. Peak is reset by cycling power, initiating a run, or resetting drive.
- 16: Peak input voltage. Peak is reset by cycling power, initiating run, or resetting drive.  
Calculated from DC bus.

Item 276, FREQUENCY METER ADJUSTMENT - This setting adjusts the gain of the "FM" terminal. With Item 275 set to "14" (or Item 277 for the "AM" terminal), press the up/down arrows (ignoring parameter value shown) until external meter/system reads the following value for the chosen operating variable:

- For *post compensation frequency*, adjust until meter/system reads 75% of Item 1, MAXIMUM OUTPUT FREQUENCY
- For *post-compensation output frequency*, adjust until meter/system reads 75% of Item 1, MAXIMUM OUTPUT FREQUENCY
- For *frequency command*, adjust until meter/system reads 75% of Item 1, MAXIMUM OUTPUT FREQUENCY
- For *output current*, adjust until meter/system reads drive rated amps (or 100%)
- For *DC bus voltage*, adjust until meter/system 283 VDC for a 230 V drive or 566 VDC for a 460 V drive.
- For *output voltage*, adjust arrows until meter/system reads 200 VAC (or 100%) for a 230 V drive or 400 VAC (or 100%) for a 460 V drive.
- For *torque current*, adjust arrows until meter/system reads drive rated amps (or 100%).
- For *excitation current*, adjust arrows until meter/system reads drive rated amps (or 100%).
- For *PID feedback value*, adjust arrows until meter/system reads 75% of Item 1, MAXIMUM OUTPUT FREQUENCY.
- For *motor overload ratio*, adjust arrows until meter/system reads 100%.
- For *inverter overload ratio*, adjust arrows until meter/system reads 100%.
- For *dynamic braking resistor overload ratio*, adjust arrows until meter/system reads 100%.
- For *input power*, adjust arrows until meter/system reads 346 X drive FLA for a 230 V drive or 692 X drive FLA for a 460 V drive.
- For *output power*, adjust arrows until meter/system reads 346 X drive FLA for a 230 V drive or 692 X drive FLA for a 460 V drive.
- For *peak output current*, adjust arrows until meter/system reads drive rated amps (or 100%).
- For *peak input voltage*, adjust arrows until meter/system reads 200 VAC for a 230 V drive or 400 VAC for a 460 V drive.

## Parameter Explanations (cont'd)

Item 277, AM TERMINAL FUNCTION SELECTION - This parameter is programmed like Item 275, but it affects the "AM" terminal.

Item 278, AMMETER ADJUSTMENT - This parameter is programmed like Item 276, but it affects the "AM" terminal.

Item 279, INDUSTRIAL APPLICATION SELECTION - This parameter can be changed only when the drive's output is 0.0 Hz. When programmed with a non zero value, the drive will initialize itself (prior programming is erased) to parameter values that lend themselves to specific applications. Contact your Toshiba distributor for a copy of the G3 Industrial Application Manual which lists the specific parameter setting by application macro. When read, this parameter displays two values; the one on the left is the previous value, while the one on the right is the current value.

Item 280, STANDARD SETTING MODE SELECTION - This parameter can be changed only when the drive's output is 0.0 Hz. When read, this parameter displays two values; the one on the left is the previous value, while the one on the right is the current value. This parameter resets the parameter values of the drive as follows:

- 1: Default drive to typical 50 Hz application settings.
- 2: Default drive to typical 60 Hz application settings.
- 3: Default drive to Toshiba factory settings listed in "Factory Setting" column on pages 8-1 through 8-32. Past four faults in the monitor erased.
- 4: Erase past four faults in the monitor.
- 5: Save present parameter settings in separate "user" default memory.
- 6: Default drive to "user" default memory.
- 7: Clear INVERTER TYPEFORM ERROR (also defaults drive to factory values).

Item 281, COMMAND MODE SELECTION - Changes to this parameter go into effect only when the drive is at 0.0 Hz. This parameter determines where the drive looks for a stop/start command:

- 0: RS232 port
- 1: G3 terminal strip only (remote mode)
- 2: G3 keypad stop/start buttons only (local mode)
- 3: RS485 input on option boards INV3-COM-A, INV3-COM-B, or INV3-COM-C
- 4: Local or remote as determined by setting of LOCAL/REMOTE button on keypad

Terminal strip enable, reset, and ESTOP commands are always valid, regardless of Item 281's setting. With this parameter set to "2", preset speeds from terminal strip will not function.

Item 282, FREQUENCY MODE SELECTION - Changes to this parameter go into effect only when the drive is at 0.0 Hz. This parameter determines where the drive looks for its output frequency reference:

- 0: RS232 port
- 1: G3 terminal strip only (remote mode)
- 2: G3 keypad stop/start buttons only (local mode)
- 3: RS485 or 12 bit binary input on option boards INV3-COM-A, INV3-COM-B, INV3-COM-C, or VF5X-4526A
- 4: Local or remote as determined by setting of LOCAL/REMOTE button on keypad

Terminal strip enable, reset, and ESTOP commands are always valid, regardless of Item 282's setting.



## Parameter Explanations (cont'd)

Item 283, `PANEL OPERATION MODE SELECTION` - Cycle power after changing this parameter. This parameter limits what can be done via the keypad. Panel ESTOP in remote mode is ALWAYS valid. The values entered here that are zero or are a power of two have one function assigned to them:

- |                            |                           |
|----------------------------|---------------------------|
| 0: Keypad does nothing     | 1: Reset drive fault only |
| 2: Monitor only            | 4: ESTOP only             |
| 8: Run/Stop only           | 16: Read parameters only  |
| 32: Change parameters only |                           |

The rest of the possible parameter values are combinations of the above.  
 Note: to "change parameters only", "read parameters only" must also be selected.

### TO RESET AFTER "0" HAS BEEN PROGRAMMED IN ITEM 283:

1. Press four keys simultaneously: LOCAL/REMOTE, PRG, READ/WRITE, and *up arrow*
2. Drive will display `ENTER PASS NUMBER 0`
3. Pass number is programmed in Item 284, `PASS NUMBER`. Enter pass number with arrows and hit READ/WRT.
4. If entered correctly, `PASS NUMBER ENTERED CORRECTLY` will display briefly and Item 283 will be reset to a value of 63, allowing all keypad operations.

If `ENTER PASS NUMBER` doesn't appear after pressing the four keys, cycle power and try again.

Item 284, `PASS NUMBER` - Incorrect entry of the setting in this parameter prevents resetting keypad lockout (Item 283 set to "0"). Item 284 is viewable through RS232 port.

Item 285, `CPU VERSION` - This is a read-only parameter. This manual is for the version 120 CPU. Version 120 added the following features to version 5101: input terminal functions 52,53, and 54; output terminal functions 62 and 63; "RR" special input function #4; PID lower limit, peak voltage, peak current, and calibration settings for AM/FM terminal functions; peak voltage and peak current monitor choices; drooping control.

Item 286, `ROM VERSION` - This is a read-only parameter. "5120" is the default setting with a version 120 CPU (230/460 volt drive). "6600" or "6610" is the setting for 600 volt drives (version 6610 added 250 HP settings). Application-specific option ROMs are available from Toshiba.

Item 287, `EEPROM VERSION` - This read-only parameter shows control board EEPROM version.

Item 288, `INVERTER TYPEFORM` - This read-only parameter identifies the G3's model number:

Typeform	Model	Typeform	Model	Typeform	Model
21	G3U2010	22	G3U2015	65	G3U6060
23	G3U2025	24	G3U2035	67	G3U6120
25	G3U2055	26	G3U2080	68	G3U6160
27	G3U2110	28	G3U2160	69	G3U6220
29	G3U2220	2A	G3U2270	6A	G3U6270
2B	G3U2330	42	G3U4015	6B	G3U6330
43	G3U4025	44	G3U4035	6C	G3U6400
45	G3U4055	46	G3U4080	6D	G3U6500
47	G3U4110	48	G3U4160	6E	G3U6600
49	G3U4220	4A	G3U4270	6F	G3U6750
4B	G3U4330	4C	G3U4400	70	G3U610K
4D	G3U4500	4E	G3U4600	71	G3U612K
4F	G3U4750	50	G3U410K	72	G3U615K
51	G3U412K	52	G3U415K	73	G3U620K
53	G3U420K	54	G3U425K	74	G3U625K
55	G3U430K	56	G3U435K		

## Parameter Explanations (cont'd)

Items 289-292, STATUS MONITOR #<1,2,3,and 4> SELECT - Pressing MON button displays the drive's monitor mode. See Item 296 to display currents in amps or percent. See Item 297 to display voltages in volts or percent. The drive operation variable displayed in four of the monitor mode's screens are selectable:

- 1: Post-compensation output frequency may be higher than frequency command (drive overspeeds to compensate for slip in vector control).
- 2: Frequency command. Not affected by stopping or accel/decel.  
Default for STATUS MONITOR #1 DISPLAY SELECT
- 3: Output current.  $(\text{output amps})^2 = (\text{torque amps})^2 + (\text{excitation amps})^2$   
Default for STATUS MONITOR #2 DISPLAY SELECT
- 4: Input voltage (calculated from DC bus voltage). If displayed in percent, note that 230 V G3s consider 200 V to be 100% input and 460 V G3s consider 400 V to be 100% input.  
Default for STATUS MONITOR #3 DISPLAY SELECT
- 5: Output voltage. If displayed in percent, note that 230 V G3s consider 200 V to be 100% output and 460 V G3s consider 400 V to be 100% output.  
Default for STATUS MONITOR #4 DISPLAY SELECT
- 6: Torque current.  $(\text{output current})^2 = (\text{torque current})^2 + (\text{excitation current})^2$
- 7: Excitation current.  $(\text{output current})^2 = (\text{torque current})^2 + (\text{excitation current})^2$
- 8: PID feedback value. This is the frequency represented by the feedback signal
- 9: Motor overload ratio. Example: G3 is rated for 150% FLA for 2 minutes. If G3 runs at 150% for one minute, this output will be 50%. Drive trips when ration hits 100%.
- 10: Inverter overload ratio. See example for selection 9 above.
- 11: Dynamic braking resistor overload ratio. See example for selection 9 above.
- 12: Input power
- 13: Output power
- 14: "RR" terminal input value (the variable displayed here varies with the setting of Item 79, RR INPUT SPECIAL FUNCTION SELECT).
- 15: Peak output current. Peak is reset by cycling power, initiating a run, or resetting drive.
- 16: Peak input voltage. Peak is reset by cycling power, initiating run, or resetting drive.  
Calculated from DC bus. If displayed in percent, note that 230 V G3s consider 200 V input to be 100% and that 460 G3s consider 400 V input to be 100%.

Item 293, FREQUENCY UNITS SCALE FACTOR - Drive's frequency output display can be scaled by putting a non-zero value here. Drive's display will still read OUTPUT FREQUENCY, but HZ will no longer be visible.

Item 294, FREQUENCY DISPLAY RESOLUTION - Use this parameter to select the number of decimal points for keypad's output frequency display.

Item 295, ACC/DEC TIME UNITS SELECTION - Affects Items 10,11,21, and 22 (sets resolution of accel/decel times).

Item 296, CURRENT UNITS SELECTION - With this parameter set to "1", drive displays currents in amps.

Item 297, VOLTAGE UNITS SELECTION - With this parameter set to "0", the voltages displayed in the monitor are in percent.

Item 298, BLIND FUNCTION SELECTION - Page 8-31 contains the parameters that unblind the G3's programming groups. Item 298 must be set to "1" before Items 299-315 can be read or changed.

Item 299, FUNDAMENTAL PARAMS #2 BLIND - This parameter must be set to "1" before any of the parameters on page 8-2 can be read or changed. Putting a "1" here adds GROUP: FUNDAMENTAL PARAMETERS #1 to the group list (accessed via the PRG button).

## Parameter Explanations (cont'd)

Item 300, PANEL CONTROL PARAMS BLIND - This parameter must be set to "1" before any of the parameters on page 8-3 can be read or changed. Putting a "1" here adds GROUP: PANEL CONTROL PARAMETERS to the visible group list (accessed via the PRG button).

Item 301, TERMINAL SELECTION PARAMS BLIND - This parameter must be set to "1" before any of the parameters on pages 8-5 through 8-7 can be read or changed. Putting a "1" here adds GROUP: TERMINAL SELECTION PARAMETERS to the visible group list (accessed via the PRG button).

Item 302, SPECIAL CONTROL PARAMS BLIND - This parameter must be set to "1" before any of the parameters on page 8-3 can be read or changed. Putting a "1" here adds GROUP: SPECIAL CONTROL PARAMETERS to the visible group list (accessed via the PRG button).

Item 303, FREQUENCY SETTING PARAMS BLIND - This parameter must be set to "1" before any of the parameters on pages 8-8 through 8-12 can be read or changed. Putting a "1" here adds GROUP: FREQUENCY SETTING PARAMETERS to the visible group list (accessed via the PRG button).

Item 304, PROTECTION FUNCTION PARAMS BLIND - This parameter must be set to "1" before any of the parameters on pages 8-13 through 8-15 can be read or changed. Putting a "1" here adds GROUP: PROTECTION FUNCTION PARAMETERS to the visible group list (accessed via the PRG button).

Item 305, PATTERN RUN CONTROL PARAMS BLIND - This parameter must be set to "1" before any of the parameters on pages 8-16 through 8-21 can be read or changed. Putting a "1" here adds GROUP: PATTERN RUN CONTROL PARAMETERS to the visible group list (accessed via the PRG button).

Item 306, FEEDBACK CONTROL PARAMS BLIND - This parameter must be set to "1" before any of the parameters on pages 8-22 through 8-23 can be read or changed. Putting a "1" here adds GROUP: FEEDBACK CONTROL PARAMETERS to the visible group list (accessed via the PRG button).

Item 307, COMMUNICATION PARAMETERS BLIND - This parameter must be set to "1" before any of the parameters on pages 8-24 through 8-25 can be read or changed. Putting a "1" here adds GROUP: COMMUNICATION PARAMETERS to the visible group list (accessed via the PRG button).

Item 308, INDUSTRIAL APPL: PUMP PARAMS BLIND - Putting a "1" here adds GROUP: INDUSTRIAL APPLICATION - PUMP to the visible group list (accessed via the PRG button). This group contains parameters from other groups which may be useful when programming the drive for a pump application. The settings of these parameters are still set at factory default. Contact your Toshiba distributor for the Industrial Application Manual for more information on the pump group.

Item 309, INDUSTRIAL APPL: FAN PARAMS BLIND - Putting a "1" here adds GROUP: INDUSTRIAL APPLICATION - FAN to the visible group list (accessed via the PRG button). This group contains parameters from other groups which may be useful when programming the drive for a fan application. The settings of these parameters are still set at factory default. Contact your Toshiba distributor for the Industrial Application Manual for more information on the fan application group.

Item 310, INDUSTRIAL APPL: CONVEYOR BLIND - Putting a "1" here adds GROUP: INDUSTRIAL APPL - CONVEYOR to the visible group list (accessed via the PRG button). This group contains parameters from other groups which may be useful when programming the drive for a conveyor application. The settings of these parameters are still set at factory default. Contact your Toshiba distributor for the Industrial Application Manual for more information on the conveyor application group.

Item 311, INDUSTRIAL APPL: HOIST BLIND - Putting a "1" here adds GROUP: INDUSTRIAL APPLICATION - HOIST to the visible group list (accessed via the PRG button). This group contains parameters from other groups which may be useful when programming the drive for a hoist application. The settings of these parameters are still set at factory default. Contact your Toshiba distributor for the Industrial Application Manual for more information on the hoist application group.



## Parameter Explanations (cont'd)

Item 312, INDUSTRIAL APPL: TEXTILES BLIND - Putting a "1" here adds GROUP:INDUSTRIAL APPL - TEXTILES to the visible group list (accessed via the PRG button). This group contains parameters from other groups which may be useful when programming the drive for a textile application. The settings of these parameters are still set at factory default. Contact your Toshiba distributor for the Industrial Application Manual for more information on the textile application group.

Item 313, INDUSTRIAL APPL: TOOLS BLIND - Putting a "1" here adds GROUP:INDUSTRIAL APPL - MACHINE TOOLS to the visible group list (accessed via the PRG button). This group contains parameters from other groups which may be useful when programming the drive for a machine tool application. The settings of these parameters are still set at factory default. Contact your Toshiba distributor for the Industrial Application Manual for more information on the machine tool application group.

Item 314, AM/FM ADJUSTMENT PARAMS BLIND - This parameter must be set to "1" before any of the parameters on page 8-27 can be read or changed. Putting a "1" here adds GROUP:AM/FM ADJUSTMENT PARAMS to the visible group list (accessed via the PRG button).

Item 315, MOTOR PARAMETERS BLIND - This parameter must be set to "1" before any of the parameters on page 8-31 can be read or changed. Putting a "1" here adds GROUP:MOTOR PARAMETERS to the visible group list (accessed via the PRG button).

Item 316, NUMBER OF MOTOR POLES - Enter number of motor poles.

Item 317, MOTOR RATED CAPACITY - Enter motor KW. 1 HP = 0.746 KW.

Item 318, MOTOR TYPE - This parameter describes the motor as follows:

- 0: Toshiba/Houston EQP3 (premium efficiency)
- 1: Toshiba/Houston High Efficient (standard efficiency)
- 2: Non-Toshiba/Houston motor

Item 319, MOTOR RATED VOLTAGE - Enter motor nameplate voltage.

Item 320, MOTOR RATED FREQUENCY - Enter motor nameplate frequency.

Item 321, MOTOR RATED RPM - Enter motor nameplate full-load RPM.

Item 322, AUTO-TUNING ENABLE - To auto-tune a motor, enter a "1" here. When the next run is initiated, the drive performs an autotuning which lasts a fraction of a second. Item 322 is then reset to "0".

Item 323, LOAD MOMENT OF INERTIA - Estimate the load's inertia as follows:

- 0: Small
- 1: Medium
- 2: Large
- 3: Very large

In the event of an AUTO-TUNING ERROR, try a different inertia level.

## Programming Examples

### Preset Speed Example

The following example uses "S1" and "S2" terminals to access three preset speeds of 11.0 Hz (close "S1"- "CC"), 55.0 Hz (close "S2"- "CC"), and 33.7 Hz (close "S1" and "S2" to "CC"). "F"- "CC" and "ST"- "CC" must be made on the drive's terminal strip. This example assumes drive is defaulted to factory settings prior to when the following programming is done.

Group	Parameter	Value
UTILITY PARAMETERS	BLIND FUNCTION SELECTION	1
UTILITY PARAMETERS	FREQUENCY SETTING PARAMETERS BLIND	1
FREQUENCY SETTING PARAMETERS	PRESET SPEED SELECTION	3
FREQUENCY SETTING PARAMETERS	PRESET SPEED MODE ACTIVATION	0
FREQUENCY SETTING PARAMETERS	PRESET SPEED #1 FREQUENCY	11
FREQUENCY SETTING PARAMETERS	PRESET SPEED #1 OPERATING MODE	0
FREQUENCY SETTING PARAMETERS	PRESET SPEED #2 FREQUENCY	55
FREQUENCY SETTING PARAMETERS	PRESET SPEED #2 OPERATING MODE	0
FREQUENCY SETTING PARAMETERS	PRESET SPEED #3 FREQUENCY	33.7
FREQUENCY SETTING PARAMETERS	PRESET SPEED #3 OPERATING MODE	0

LOCAL LED must be off to run from terminal strip. See page 9-15 for parameter explanations.

### Trim Pot Example

This example uses the "RX" terminal to trim a reference (i.e. a 4-20 mA input) +7/-5 Hz.

Group	Parameter	Value
UTILITY PARAMETERS	BLIND FUNCTION SELECTION	1
UTILITY PARAMETERS	FEEDBACK CONTROL PARAMETERS BLIND	1
UTILITY PARAMETERS	FREQUENCY SETTING PARAMETERS BLIND	1
FEEDBACK PARAMETERS	OVERRIDE CONTROL SELECTION	3
FREQUENCY SETTING PARAMETERS	RX TERMINAL STANDARD OR ADJUSTABLE	1
FREQUENCY SETTING PARAMETERS	RX REFERENCE SETTING POINT #1	0 %
FREQUENCY SETTING PARAMETERS	RX REFERENCE POINT #1 FREQUENCY	7 HZ
FREQUENCY SETTING PARAMETERS	RX REFERENCE SETTING POINT #2	100 %
FREQUENCY SETTING PARAMETERS	RX REFERENCE POINT #2 FREQUENCY	-5 HZ

### Motor Operated Pot

The following programming allows a G3 to emulate motor operated pot control. Momentarily shorting "S1"- "CC" increases frequency reference. Momentarily shorting "S2"- "CC" decreases frequency reference. Momentarily shorting "S3"- "CC" erases frequency reference. "F"- "CC" and "ST"- "CC" must be made on the drive's terminal strip. This example assumes drive is defaulted to factory settings prior to the following programming is done.

Group	Parameter	Value
UTILITY PARAMETERS	BLIND FUNCTION SELECTION	1
UTILITY PARAMETERS	TERMINAL SELECTION PARAMETERS BLIND	1
UTILITY PARAMETERS	FREQUENCY SETTING PARAMETERS BLIND	1
TERMINAL SELECTION PARAMETERS	INPUT TERMINAL SELECTION	1
TERMINAL SELECTION PARAMETERS	"S1" INPUT TERMINAL FUNCTION	34
TERMINAL SELECTION PARAMETERS	"S2" INPUT TERMINAL FUNCTION	35
TERMINAL SELECTION PARAMETERS	"S3" INPUT TERMINAL FUNCTION	36
FREQUENCY SETTING PARAMETERS	FREQUENCY PRIORITY SELECTION #1	5

The LOCAL LED must be off to run from terminal strip. See pages 9-7 and 9-13 for parameter explanations.

## Programming Examples (con't)

### True Torque Control Programming

The G3 can be programmed to utilize True Torque Control (TTC), the benefits of which are slip compensation and high torque at low speed. In volts per hertz control (or across the line), a typical AC induction motor will lose 3-5% of its RPM as it goes from no load to full load; when operated on a G3 in TTC mode, a motor will slow a maximum of 0.5% of base RPM as it is loaded. Motors operated on volts per hertz drives cannot develop their rated torque when operated at low frequencies; the same motor operated on a G3 in TTC mode can typically develop 200% of its rated torque at one Hz.

The G3 divides the motor current it is providing into two components that are ninety degrees out of phase: the excitation current and the torque current. Excitation current is the part of the total current that develops the magnetic field in the motor's core. The torque current is the current that does the useful work. According to the Pythagorean theorem,  $(\text{total current})^2 = (\text{torque current})^2 + (\text{excitation current})^2$ . The G3 calculates and controls these currents based on motor models to optimize motor performance.

If a Toshiba/Houston motor is used, the drive will use an on-board motor model. If a generic motor is used, the drive can be programmed to auto-tune. During auto tuning, the drive derives a motor model by applying a voltage to the motor and analyzing the resulting decay.

These G3 parameters must be adjusted to use TTC with a TOSHIBA/HOUSTON motor.

Group	Parameter	Value
UTILITY PARAMETERS	BLIND FUNCTION SELECTION	1
UTILITY PARAMETERS	MOTOR PARAMETERS BLIND	1
FUNDAMENTAL PARAMETERS #1	VOLTS PER HERTZ PATTERN	5
MOTOR PARAMETERS	NUMBER OF MOTOR POLES	*
MOTOR PARAMETERS	MOTOR RATED CAPACITY	*
MOTOR PARAMETERS	MOTOR TYPE	**
MOTOR PARAMETERS	LOAD MOMENT OF INERTIA	***

The following parameters must be adjusted to use TTC on the G3 for a GENERIC motor.

Group	Parameter	Value
UTILITY PARAMETERS	BLIND FUNCTION SELECTION	1
UTILITY PARAMETERS	MOTOR PARAMETERS BLIND	1
FUNDAMENTAL PARAMETERS #1	VOLTS PER HERTZ PATTERN	5
MOTOR PARAMETERS	NUMBER OF MOTOR POLES	*
MOTOR PARAMETERS	MOTOR RATED CAPACITY	*
MOTOR PARAMETERS	MOTOR TYPE	2
MOTOR PARAMETERS	MOTOR RATED VOLTAGE	*
MOTOR PARAMETERS	MOTOR RATED FREQUENCY	*
MOTOR PARAMETERS	MOTOR RATED RPM	*
MOTOR PARAMETERS	AUTO-TUNING ENABLE	1****
MOTOR PARAMETERS	LOAD MOMENT OF INERTIA	***

\* Enter appropriate value from motor's nameplate. KW = 0.746 X HP.

\*\* Enter "0" for an EQPIII or "1" for a high efficiency motor.

\*\*\* If the drive displays AUTO TUNE ERROR, try a different inertia setting.

\*\*\*\* The drive will auto tune the next time a run is initiated. This parameter is then reset to "0" by the G3.

**SECTION 10: Service**

**Requesting Service**

When requesting service, report the contents of the following problem information sheet.

**Problem Information Sheet**

Item			
	Customer's name		
Refer to	Person in charge		
	Address		
	Telephone No.		
Inverter spec.	Model No.		
	Serial No.		
	Test No.		
Delivery date			
Time in service			
Date when problem arose			
	Use		
Status of Use	Motor rating	Poles, Hp, V, Hz.	
		Made by Toshiba? Made by another company?	
		New? Number of units?	
		Alternate? Continuous?	
	Ambient condition	Indoor? Outdoor? Temperature range?	
		Humidity:	
		Dust composition and size:	
		Presence of salt and extent of corrosion from it:	
		Vibrations, in micrometers:	
		Presence of corrosive gas:	
Phenomenon	Power source	Availability of air conditioning:	
		Number of phases:	
		Voltage between L1 phase and L2 phase:	
		Voltage between L2 phase and L3 phase:	
	State of motor when problem was found	Voltage between L3 phase and L1 phase:	
		Number of Hz:	
		Problem occurred _____ hours after motor had been started. Motor has been stopped for _____ hours.	
		Problem occurred during periodic inspection?	
		Problem occurred when motor was started?	
		Problem occurred during acceleration?	
	Frequency of problem	Problem occurred during deceleration?	
		Problem occurred while motor was not running?	
		First time? Problem occurred _____ times in the past.	
Problem occurs sometimes?			
Trouble indicator	Problem occurs every time motor is operated?		
	When did problem first occur?		
	Indicate LCD Screen Message:		
Detailed description of problem:			
Temporary diagnosis and corrective action:			
Date defective product shipped:		To:	
Deadline for repairs:			

**Only qualified personnel should be allowed to service this equipment.**

**Parts Service Life**

In order to obtain the best performance and to get the maximum service life from the inverter it is necessary to perform timely maintenance repairs on some parts of the system even though the equipment may still be functioning with no apparent problems

Use the following service life chart as a guide for major part periodic replacement when the equipment is used in a standard installation service environment.

**Service Life Replacement Chart**

Part Name	Service Life	Remarks
Large capacity electrolytic capacitor	5 Years	To be electrified semiannually in case of long term disuse.
Cooling Fan (if applicable)	26000 Hours	Internal fans
Contact relays	500,000 operations	
Connectors	100 operations	Replace pin in case of failure.

## Troubleshooting

If the G3 faults, the following questions may help to pinpoint the reason for the trip:

1. Does the drive trip when accelerating, running, decelerating, or when not running ?
2. Can the drive make it to commanded frequency ?
3. Does the drive trip without the motor attached ?
4. Does drive trip with an unloaded motor ?

Drive data at the time of trip is saved in the monitor and can be read until the trip is cleared. Before clearing the trip, make a note of this information. A history of past faults can be viewed by pressing the MON button and then the down arrow until PAST FAULTS are displayed. Some trips are the result of improper programming; resetting the drive to factory settings may be a solution (see Item 280, STANDARD SETTING MODE SELECTION).

### How to clear a fault

1. Cycling power
2. Pressing the STOP/CLEAR button twice
3. Closing "RES"- "CC" on the terminal strip (with default drive programming).

If Item 172, FAULT TRIP EEPROM SAVE ENABLE is set to "1", the drive will power up with the fault display, but the fault monitor and any fault contacts will be reset. On OVERLOAD trips, reset can occur only after a cooling time; see explanation for Item 161, OVERLOAD SELECTION. No cooling time for reset is required when power is cycled.

### RETRY

See Items 153, NUMBER OF RETRY ATTEMPTS and Item 154, TIME BETWEEN RETRY ATTEMPTS to program drive to automatically attempt to reset faults. Drive will display ATTEMPTING TO RESTART during retries. See page 9-12 for a list of faults to retry. Retry will not function if Item 172, FAULT TRIP EEPROM SAVE ENABLE is set to "1" (on).

**The keypad, control board (with phone jack), and terminal strip board are common to all ratings of G3. If a board or keypad is suspect, exchange with a known good board/keypad to verify.**

## G3 Fault Explanations

OVERCURRENT (ACCEL) or DC OVERCURRENT (ACC)

*Cause:* Drive current exceeded 215% of its rated FLA (190% above 100 HP).

*Comments:* Check for phase-phase short. ACCELERATION TIME may be too small. VOLTAGE BOOST may be too high. Is motor/machine jammed? Is mechanical brake engaged while drive is running? If G3 is starting into a rotating motor, see Item 157, AUTO-RESTART (MOTOR SPEED SEARCH). If there is a contactor between motor and drive, wire so that contactor changes state only when drive is outputting 0.0 Hz. Drive will automatically adjust accel time with Item 12, ACC/DEC PATTERN #1 SELECTION set to "1".

OVERCURRENT (DECEL) or DC OVERCURRENT (DEC)

*Cause:* Drive current exceeded 215% of its rated FLA (190% above 100 HP).

*Comments:* Check for phase-phase short. DECELERATION TIME may be too small. Is motor/machine jammed? Is mechanical brake engaged while drive is running? Adding appropriate braking resistor across "PA" and "PB" terminals may solve problem (see page 9-16). Drive will automatically adjust decel time with Item 12, ACC/DEC PATTERN #1 SELECTION set to "1".

OVERCURRENT (RUN) or DC OVERCURRENT (RUN)

*Cause:* Drive current exceeded 215% of its rated FLA (190% above 100 HP).

*Comments:* Check for phase-phase short. Is motor/machine jammed? Is mechanical brake engaged while drive is running? Adding appropriate dynamic braking resistor across "PA" and "PB" terminals may solve problem (see page 9-16). If there are severe load fluctuations, adding mechanical dampening or an output line reactor may help to electrically damp.

## G3 Fault Explanations (con't)

### U-PHASE SHORT-CIRCUIT or V PHASE SHORT-CIRCUIT or W PHASE SHORT-CIRCUIT

*Cause:* Drive detected short-circuit in transistor.

*Comments:* Replace transistor. Contact your Toshiba distributor for authorized repair.

### LOAD-END OVERCURRENT

*Cause:* Drive detected short-circuit on output.

*Comments:* Check for phase-phase short. Meg motor/leads **with leads disconnected from drive**. Remove any power factor correction caps on motor. See Item 169, OUTPUT SHORT-CIRCUIT DETECTION SELECT.

### OVERVOLTAGE (ACCEL) or OVERVOLTAGE (RUN)

*Cause:* Bus exceeded 393 VDC (230 V G3), 787 VDC (460 V G3), or 1179 VDC (600 V G3).

*Comments:* Incoming AC may have gone high or spiked (verify with Item 289,290, 291, or 292 set to "16"); a line reactor or a lower tap on transformer may help. Motor may be mechanically forced to run faster than drive is commanding; install appropriate dynamic braking resistor (see page 9-16). On eccentric cyclic loads like presses or pump jacks, contact your Toshiba distributor for special programming instructions that may make a DBR unnecessary.

### OVERVOLTAGE (DEC)

*Cause:* Bus exceeded 393 VDC (230 V G3), 787 VDC (460 V G3), or 1179 VDC (600 V G3).

*Comments:* Incoming AC may have gone high or spiked (verify with Item 289 set to "16"); a line reactor or a lower tap on transformer may help. Item 11, DECELERATION TIME #1 may be too short. Drive will automatically change decel time with Item 12, ACC/DEC PATTERN ADJUST LOW set to "1". Make sure Item 145, OVERVOLTAGE STALL PROTECTION is set to "0". Motor may be mechanically forced to run faster than drive is commanding (due to large load inertias mechanical couplings); install appropriate dynamic braking resistor (see page 9-16). On eccentric cyclic loads like presses or pump jacks, contact your Toshiba distributor for special programming instructions that may make a DBR unnecessary.

### INVERTER OVERLOAD

*Cause:* Drive exceeded 110% of its rated current for too long of a time.

*Comments:* This trip indicates that the G3 output more than its rated current for specific amounts of time. For example, 100 HP and smaller G3s can output 150% of their rated current for 120 seconds, 130% for 240 seconds, 170% for 3.5 seconds, and 185% for 0.5 seconds. If using DC Injection, Item 147, DC INJECTION CURRENT MAGNITUDE or Item 148 DC INJECTION TIME they may be too large. If Item 42, PWM CARRIER FREQUENCY is greater than 8 KHz, try carrier frequencies less than 8 KHz. Programming Item 161, OVERLOAD SELECTION to "1" or "3" (soft stall on) makes the drive reduce output frequency/voltage to shed load (works best on variable torque applications). Motor or load bearings may have seized. Enabling True Torque Control (see page 9-31) may reduce drive's current output and solve problem. Make sure that drive is seeing voltage on all three of its input phases. Drive may be undersized.

### MOTOR OVERLOAD

*Cause:* Motor is in danger of overheating because it drew too much current for too long of a time, as determined by drive.

*Comments:* See page 9-17. Check Items 158, 159, 160, and 161. If trip occurred at a low frequency, the setting of Item 159, OVERLOAD REDUCTION START FREQUENCY is probably critical. Motor overload protection can be turned off by placing a "2" or "3" in Item 161. Check value in Item 160, MOTOR 150% OVERLOAD TIME LIMIT.



## G3 Fault Explanations (con't)

### DBR OVERCURRENT

*Cause:* IGBT7 (dynamic braking transistor) is damaged

*Comments:* Check ohm value connected to "PA" and "PB" terminals (see page 9-16 for minimum ohm values). If using multiple resistors, make sure parallel-series combination is wired correctly. Check IGBT7. Check DC bus fuse for continuity; if open, check output transistors. Consult your Toshiba distributor for authorized service.

### DBR OVERLOAD

*Cause:* Dynamic braking resistor is in danger of overheating (as determined by drive).

*Comments:* Check that the values entered into Item 143, BRAKING RESISTOR VALUE and Item 144, BRAKING RESISTOR POWER RATING are correct.

### OVERHEAT

*Cause:* Drive's heatsink exceeded 90° C.

*Comments:* Check drive's muffin fans (if any). Clear heatsinks of anything blocking airflow. The enclosure that the drive is installed in may be too small or there may be too many heat sources in the same enclosure. Drive may not have been properly sized for operating altitude. Thermistor on heatsink may be bad.

### EMERGENCY OFF

*Cause:* Drive received one of the following ESTOP commands:

1. Drive was receiving STOP/START command via terminal strip when STOP button on keypad was pressed.
2. One of the drive's input terminal's function is set to "10" (see Items 44-55 and page 9-9), and terminal is being opened/closed to command ESTOP.

### EEPROM WRITE FAILURE or EEPROM READ FAILURE

*Cause:* EEPROM was unable to read/write to peripherals.

*Comments:* Check for miswiring that may be causing noise (such as "CC" connected to ground, an external 10 volt source connected to "PP" etc.) Control board may need to be replaced (part number 03784). See picture of board on page 5-2.

### RAM ERROR or ROM ERROR

*Comments:* Check for miswiring that may be causing noise (such as "CC" connected to ground, an external 10 volt source connected to "PP" etc.). Replace control board (part number 03784). See picture of board on page 5-2.

### OPTION ROM ERROR

*Comments:* Check for miswiring that may be causing noise (such as "CC" connected to ground, an external 10 volt source connected to "PP" etc.). If drive is energized with option ROM installed and is later energized without option ROM installed, this fault will appear. Reset in normal fashion.

### CPU ERROR

*Comments:* If option ROM or option board is installed or removed when drive is powered, this fault will appear. Reset like any fault. Check for miswiring that may be causing noise (such as "CC" connected to ground, an external 10 volt source connected to "PP" etc.). If the CPU is truly damaged, the fault will not reset and replacement of the control board (part number 03784) is necessary. See picture of control board on page 5-2.

### COMMUNICATION ERROR

*Cause:* RS232 or RS485 timer did not respond

*Comments:* Check wiring to RS232 or RS485 ports. Check setting of Item 264, COMMUNICATION SELECTION (should be "1" for RS485). Check jumpers J1, J2, and J3 on RS485 option board (see RS485 Communications Option Manual). Cable may be broken.



## G3 Fault Explanations (con't)

### OPTION PCB ERROR

*Comments:* If drive is energized with an option board installed and is later energized without the board installed, this fault will appear. Check connectors between control board and option board. Check settings of Item 80, FREQUENCY PRIORITY SELECTION #1, Item 81, FREQUENCY PRIORITY SELECTION #2, and Item 264, COMMUNICATION SELECTION. Use stand-offs to secure board.

### LOW CURRENT TRIP

*Cause:* The drive's output current went below the current value entered in Item 167, LOW CURRENT DETECT LEVEL for at least the amount of time entered in Item 168, LOW CURRENT DETECTION TIME.

### UNDERVOLTAGE TRIP

*Cause:* The drive's DC bus voltage went below 217 VDC (230 V G3), 413 VDC (460 V G3), or 594 VDC (600 V G3) for at least the time entered in Item 165, UNDERVOLTAGE DETECT TIME.  
*Comments:* Item 164, UNDERVOLTAGE TRIP SELECTION turns the ability to undervoltage trip on/off. On G3 models 2080-2110 and 4080-4270, turning on Item 155, REGENERATION POWER RIDE-THROUGH and adjusting Item 156, REGENERATION RIDE-THROUGH TIME may keep bus up during brown out if there is sufficient regen energy from the load.

### OVERTORQUE TRIP

*Cause:* The drive's torque current went above the current value programmed in Item 171, OVERTORQUE TRIP LEVEL. The G3 can be programmed to torque current limit; contact your Toshiba distributor and request the torque limit application guideline.

### EARTH FAULT (SOFT) or EARTH FAULT (HARD)

*Cause:* Drive detected some current to ground. Depending on rating, drive senses ground fault via ZCT (hard fault) or Hall CTs (soft fault).

*Comments:* With leads disconnected from drive, meg motor and leads. Look for any moisture that may provide current path to ground. Make sure that control wiring is separated from power wiring. Adding noise suppressors on coils of starters on same line as drive may snub noise picked up by ZCT. RF/EMI filter may help remove noise generated by SCR rectifiers in the vicinity. Make sure drive chassis and motor are grounded.

### AUTO-TUNING ERROR

*Cause:* Motor's physical characteristics are not within the window of allowable values for modeling.  
*Comments:* Try a different inertia setting in Item 323, LOAD MOMENT OF INERTIA. Motor must be at rest to perform auto-tuning. Motor must be one HP size within the drive's HP size. Auto-tuning is best done with motor at full-load temperature (if temperature is very cold, auto-tune error may appear).

### GATE ARRAY FAULT

*Comments:* Replace control board, part number 03784. See picture of board on page 5-2.

### CURRENT DETECT ERROR

*Comments:* Occurs when drive is stopped but CPU detects current flowing. This fault could be caused by plugging in RS232 cable with drive powered (resulting in damage to control board). Adding a RF/EMI filter may remove noise spikes from nearby SCR rectifiers. If damaged, replace control board, part number 03784. See picture of board on page 5-2.

### INV TYPEFORM ERROR

*Cause:* Control board is not configured to drive's rating.

*Comments:* Enter "7" into Item 280, STANDARD SETTING MODE SELECTION.

## G3 Warning Explanations

### DC BUS UNDERVOLTAGE

*Cause:* The drive's DC bus voltage went below approximately 200 VDC (230 V G3), 395 VDC (460 V G3), or 595 VDC (600 V G3) for at least the time entered in Item 165, UNDERVOLTAGE DETECT TIME.

*Comments:* Item 164, UNDERVOLTAGE TRIP SELECTION turns the ability to undervoltage trip on/off.

### CONTROL POWER LOW

Control Power low warning voltage levels are sensed on DC bus and are set slightly less than DC BUS UNDERVOLTAGE levels.

### OVERLOAD

A flashing overcurrent display means that the drive is outputting more than 110% of its rated current. If Item 161, OVERLOAD SELECTION is set to "1" or "3" (soft stall on), the drive's output frequency will automatically decrease in an effort to reduce current. See suggestions for remedying an inverter overload trip on page 10-4. Setting one of the monitor's functions (Items 289-292) to "10" will give an indication of how close a drive is to tripping.

### OVERCURRENT

A flashing overcurrent display means that the drive is stalling. (Stall level is set by Item 160, STALL PROTECTION CURRENT LEVEL). The drive's output frequency will automatically decrease.

### OVERVOLTAGE

A flashing overvoltage display means that the drive's DC bus has exceeded 360 VDC (230 V G3), 720 VDC (460 V G3), or 1034 VDC (600 V G3).

### OVERHEAT

A flashing overheat display means that the drive's heat sink temperature has exceeded 84°C. Display disappears when heatsink temperature reaches 80°C.

### COMM

A flashing comm display means that the drive has momentarily lost communications. Display will clear when follower receives valid reference. Cycling power or reinitializing drive will clear warning.

## SECTION 11: Dimensions/Weights

### Basic Dimensions for NEMA 1 and NEMA 12 chassis G3s

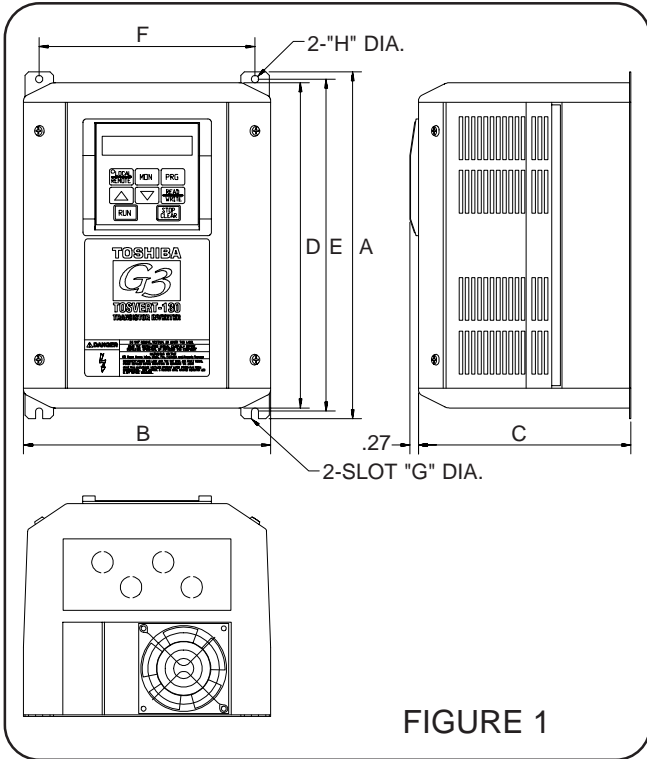

FIGURE 1

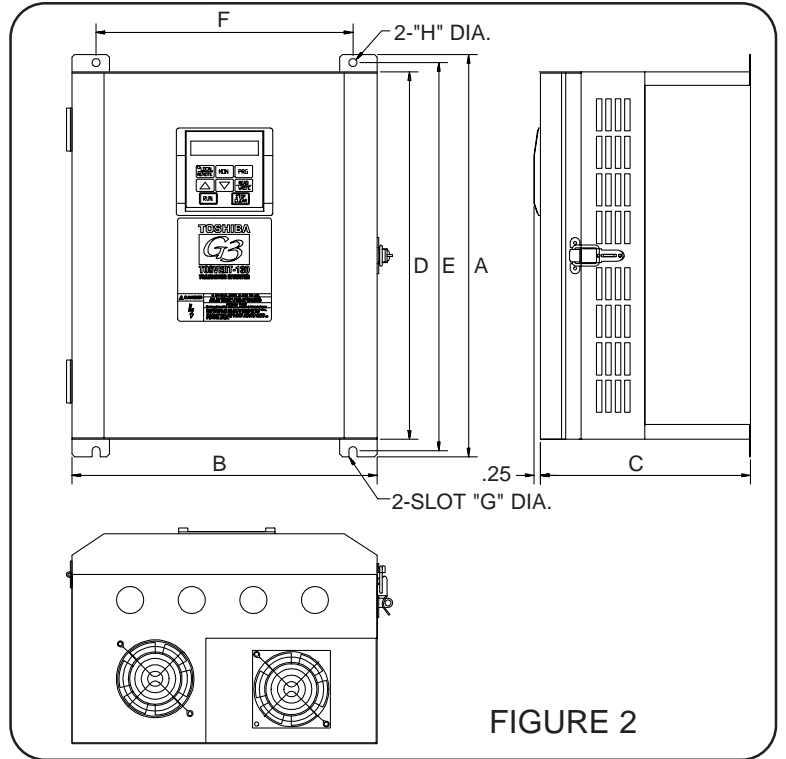

FIGURE 2

### DIMENSIONS in inches(millimeters)

MODEL	FIG	A	B	C	D	E	F	G	H
VT130G3U2010	1	12.13(308)	8.66(220)	7.44(189)	11.38(289)	11.63(295)	7.69(195)	.28(7)	.28(7)
VT130G3U2015	1	12.13(308)	8.66(220)	7.44(189)	11.38(289)	11.63(295)	7.69(195)	.28(7)	.28(7)
VT130G3U2025	1	12.13(308)	8.66(220)	7.44(189)	11.38(289)	11.63(295)	7.69(195)	.28(7)	.28(7)
VT130G3U2035	1	12.13(308)	8.66(220)	7.44(189)	11.38(289)	11.63(295)	7.69(195)	.28(7)	.28(7)
VT130G3U2055	1	12.13(308)	8.66(220)	7.44(189)	11.38(289)	11.63(295)	7.69(195)	.28(7)	.28(7)
VT130G3U2080	1	17.88(454)	8.66(220)	7.44(189)	17.13(435)	17.38(441)	7.69(195)	.28(7)	.28(7)
VT130G3U2110	2	18.75(476)	14.25(362)	9.81(249)	17.09(434)	18.09(459)	11.25(286)	.38(10)	.38(10)
VT130G3U2160	2	18.75(476)	14.25(362)	9.81(249)	17.09(434)	18.09(459)	11.25(286)	.38(10)	.38(10)
VT130G3U2220	2	18.75(476)	14.25(362)	9.81(249)	17.09(434)	18.09(459)	11.25(286)	.38(10)	.38(10)
VT130G3U2270	2	23.63(600)	17.25(438)	11.50(292)	21.63(549)	22.75(578)	14.25(362)	.38(10)	.38(10)
VT130G3U4015	1	12.13(308)	8.66(220)	7.44(189)	11.38(289)	11.63(295)	7.69(195)	.28(7)	.28(7)
VT130G3U4025	1	12.13(308)	8.66(220)	7.44(189)	11.38(289)	11.63(295)	7.69(195)	.28(7)	.28(7)
VT130G3U4035	1	12.13(308)	8.66(220)	7.44(189)	11.38(289)	11.63(295)	7.69(195)	.28(7)	.28(7)
VT130G3U4055	1	12.13(308)	8.66(220)	7.44(189)	11.38(289)	11.63(295)	7.69(195)	.28(7)	.28(7)
VT130G3U4080	1	12.13(308)	8.66(220)	7.44(189)	11.38(289)	11.63(295)	7.69(195)	.28(7)	.28(7)
VT130G3U4110	1	17.88(454)	8.66(220)	7.44(189)	17.13(435)	17.38(441)	7.69(195)	.28(7)	.28(7)
VT130G3U4160	2	18.75(476)	14.25(362)	9.81(249)	17.09(434)	18.09(459)	11.25(286)	.38(10)	.38(10)
VT130G3U4220	2	18.75(476)	14.25(362)	9.81(249)	17.09(434)	18.09(459)	11.25(286)	.38(10)	.38(10)
VT130G3U4270	2	18.75(476)	14.25(362)	9.81(249)	17.09(434)	18.09(459)	11.25(286)	.38(10)	.38(10)
VT130G3U4330	2	23.63(600)	17.25(438)	11.50(292)	21.63(549)	22.75(578)	14.25(362)	.38(10)	.38(10)
VT130G3U4400	2	23.63(600)	17.25(438)	11.50(292)	21.63(549)	22.75(578)	14.25(362)	.38(10)	.38(10)
VT130G3U4500	2	23.63(600)	17.25(438)	11.50(292)	21.63(549)	22.75(578)	14.25(362)	.38(10)	.38(10)

**NOTES:**

- 1) NEMA 12 part numbers add suffix "N12".
- 2) NEMA 12 chassis available for FIGURE 2 drives only. NEMA 1 and NEMA 12 dimensions are the same

## Basic Dimensions for NEMA 1 Chassis G3s (con't)

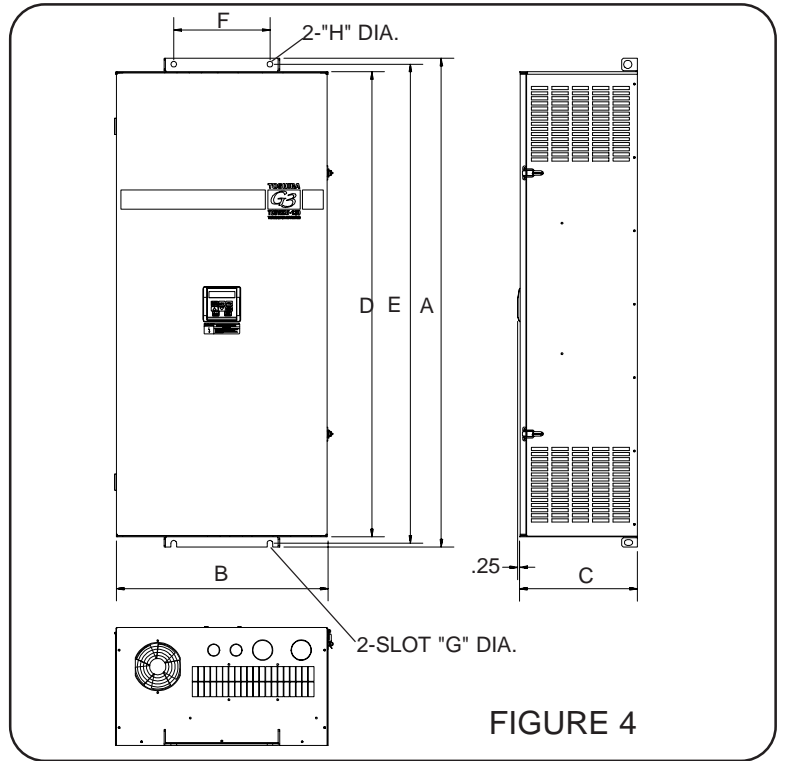
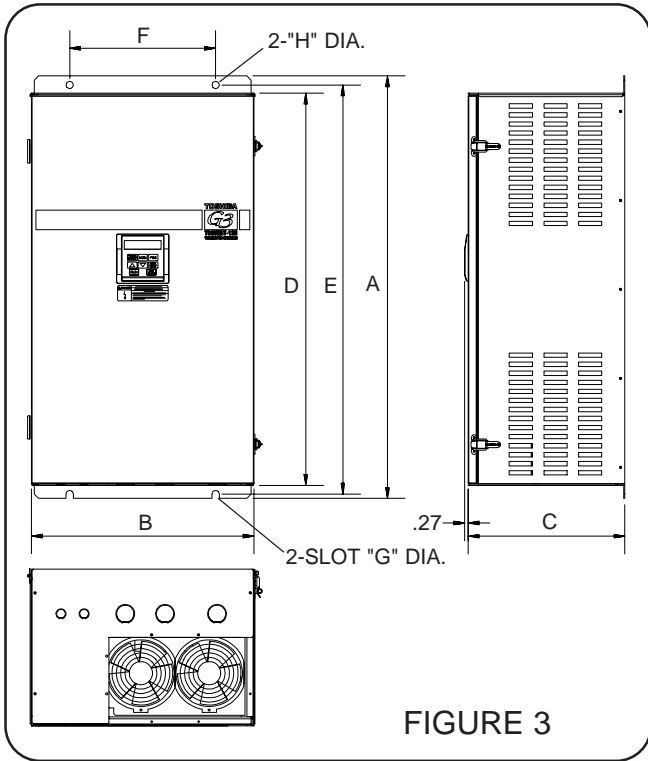

### DIMENSIONS in inches(millimeters)

MODEL	FIG	A	B	C	D	E	F	G	H
VT130G3U2330	3	36.50(927)	19.25(489)	13.56(344)	33.88(861)	35.34(898)	12.63(321)	.63(16)	.63(16)
VT130G3U4600	3	36.50(927)	19.25(489)	13.56(344)	33.88(861)	35.34(898)	12.63(321)	.63(16)	.63(16)
VT130G3U4750	3	36.50(927)	19.25(489)	13.56(344)	33.88(861)	35.34(898)	12.63(321)	.63(16)	.63(16)
VT130G3U410K	3	57.00(1448)	19.25(489)	13.16(334)	54.16(1376)	55.81(1418)	12.63(321)	.69(18)	.69(18)
VT130G3U412K	3	57.00(1448)	19.25(489)	13.16(334)	54.16(1376)	55.81(1418)	12.63(321)	.69(18)	.69(18)
VT130G3U415K	3	57.00(1448)	19.25(489)	13.16(334)	54.16(1376)	55.81(1418)	12.63(321)	.69(18)	.69(18)
VT130G3U420K	3	57.00(1448)	19.25(489)	13.16(334)	54.16(1376)	55.81(1418)	12.63(321)	.69(18)	.69(18)
VT130G3U425K	4	59.94(1522)	25.88(657)	14.47(368)	57.00(1448)	58.75(1492)	11.81(300)	.69(18)	.69(18)
VT130G3U6060	3	18.75(476)	14.38(365)	9.94(252)	17.13(435)	18.09(459)	11.25(286)	.38(10)	.38(10)
VT130G3U6120	3	20.75(527)	14.38(365)	9.94(252)	19.13(486)	20.09(510)	11.25(286)	.38(10)	.38(10)
VT130G3U6160	3	23.63(600)	17.38(441)	11.50(292)	21.63(549)	22.75(578)	14.25(362)	.50(13)	.50(13)
VT130G3U6220	3	23.63(600)	17.38(441)	11.50(292)	21.63(549)	22.75(578)	14.25(362)	.50(13)	.50(13)
VT130G3U6270	3	23.63(600)	17.38(441)	11.50(292)	21.63(549)	22.75(578)	14.25(362)	.50(13)	.50(13)
VT130G3U6330	3	36.50(927)	19.25(489)	13.56(344)	33.88(861)	35.34(898)	12.63(321)	.63(16)	.63(16)
VT130G3U6400	3	36.50(927)	19.25(489)	13.56(344)	33.88(861)	35.34(898)	12.63(321)	.63(16)	.63(16)
VT130G3U6500	3	36.50(927)	19.25(489)	13.56(344)	33.88(861)	35.34(898)	12.63(321)	.63(16)	.63(16)
VT130G3U6600	3	36.50(927)	19.25(489)	13.56(344)	33.88(861)	35.34(898)	12.63(321)	.63(16)	.63(16)
VT130G3U6750	3	36.50(927)	19.25(489)	13.56(344)	33.88(861)	35.34(898)	12.63(321)	.63(16)	.63(16)
VT130G3U610K	3	57.00(1448)	19.25(489)	13.16(334)	54.16(1376)	55.81(1418)	12.63(321)	.69(18)	.69(18)
VT130G3U612K	3	57.00(1448)	19.25(489)	13.16(334)	54.16(1376)	55.81(1418)	12.63(321)	.69(18)	.69(18)
VT130G3U615K	4	59.94(1522)	25.88(657)	14.47(368)	57.04(1449)	58.75(1492)	11.81(300)	.69(18)	.69(18)
VT130G3U620K	4	59.94(1522)	25.88(657)	14.47(368)	57.04(1449)	58.75(1492)	11.81(300)	.69(18)	.69(18)
VT130G3U625K	4	59.94(1522)	25.88(657)	14.47(368)	57.04(1449)	58.75(1492)	11.81(300)	.69(18)	.69(18)

## Basic Dimensions for NEMA 1 Chassis G3

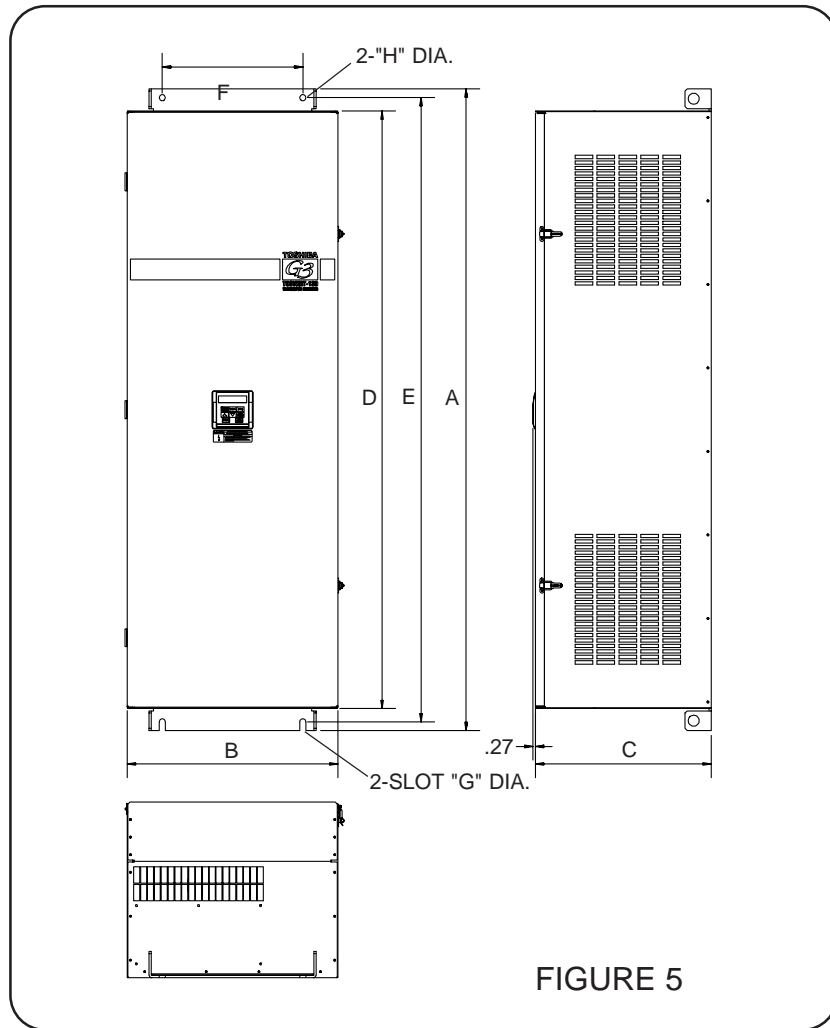

**DIMENSIONS** in inches(millimeters)

MODEL	FIG	A	B	C	D	E	F	G	H
VT130G3U430K	5	73.00(1854)	24.00(610)	20.00(508)	68.00(610)	71.00(1727)	16.00(406)	.69(18)	.69(18)
VT130G3U435K	5	73.00(1854)	24.00(610)	20.00(508)	68.00(610)	71.00(1727)	16.00(406)	.69(18)	.69(18)

## Dimensions for NEMA 4 G3 Chassis

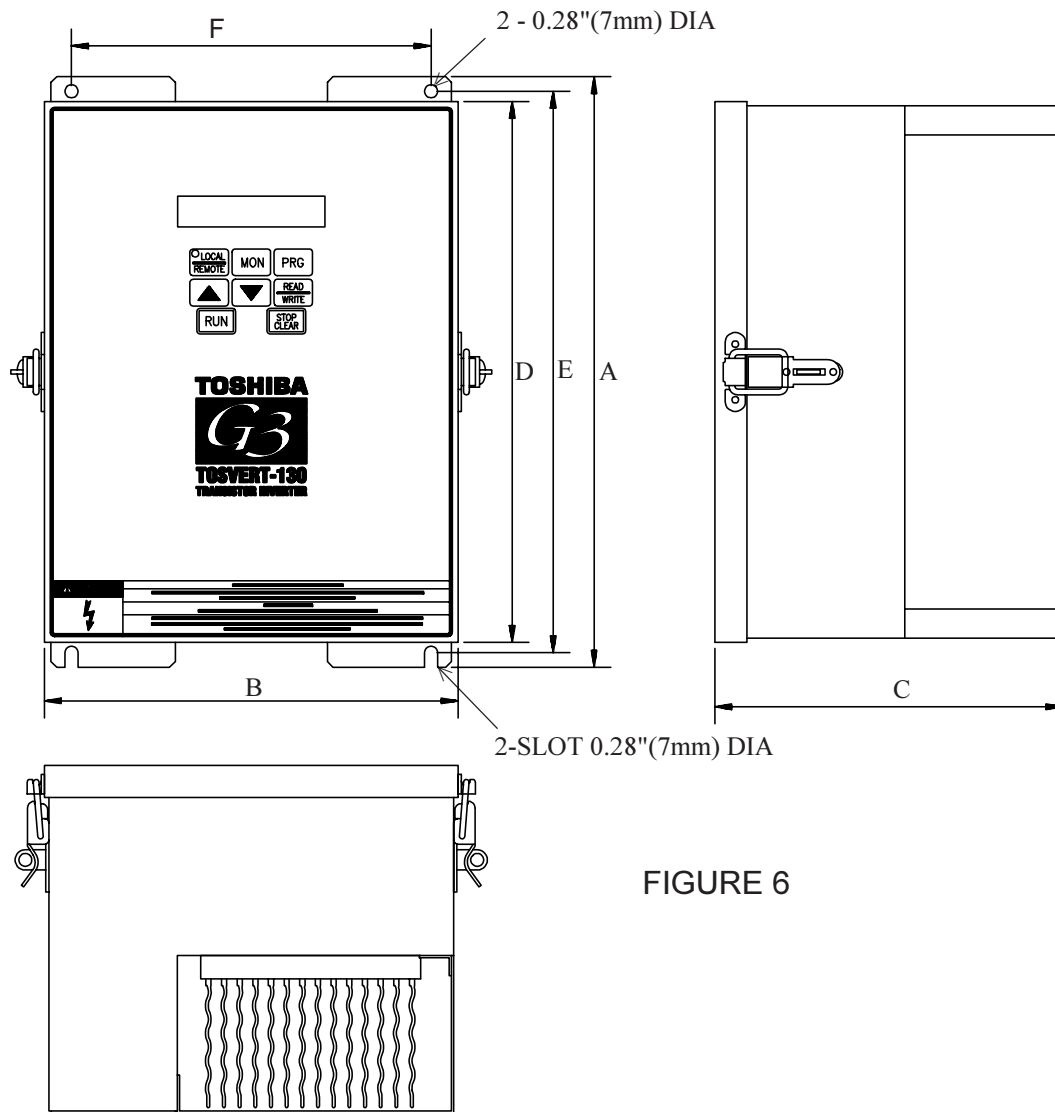

FIGURE 6

### DIMENSIONS in inches (millimeters)

MODEL	FIG	A	B	C	D	E	F
VT130G3U4015N4	6	12.63(321)	8.84(225)	7.44(189)	11.56 (294)	12.00(305)	7.69 (195)
VT130G3U4025N4	6	12.63(321)	8.84(225)	7.44(189)	11.56 (294)	12.00(305)	7.69 (195)
VT130G3U4035N4	6	12.63(321)	8.84(225)	7.44(189)	11.56 (294)	12.00(305)	7.69 (195)
VT130G3U4055N4	6	12.63(321)	8.84(225)	7.44(189)	11.56 (294)	12.00(305)	7.69 (195)
VT130G3U4080N4	6	18.38(467)	8.84(225)	7.44(189)	17.31 (440)	17.75(451)	7.69 (195)
VT130G3U4110N4	6	18.38(467)	8.84(225)	7.44(189)	17.31 (440)	17.75(451)	7.69 (195)
VT130G3U2010N4	6	12.63(321)	8.84(225)	7.44(189)	11.56 (294)	12.00(305)	7.69 (195)
VT130G3U2015N4	6	12.63(321)	8.84(225)	7.44(189)	11.56 (294)	12.00(305)	7.69 (195)
VT130G3U2025N4	6	12.63(321)	8.84(225)	7.44(189)	11.56 (294)	12.00(305)	7.69 (195)
VT130G3U2035N4	6	12.63(321)	8.84(225)	7.44(189)	11.56 (294)	12.00(305)	7.69 (195)
VT130G3U2055N4	6	18.38(467)	8.84(225)	7.44(189)	17.31 (440)	17.75(451)	7.69 (195)
VT130G3U2080N4	6	18.38(467)	8.84(225)	7.44(189)	17.31 (440)	17.75(451)	7.69 (195)

# TOSHIBA

## Shipping Weights

G3 Model	Shipping Weight		G3 Model	Shipping Weigh		G3 Model	Shipping Weight	
	Pounds	Kg		Pounds	Kg		Pounds	Kg
2010	15	6.8	4015	19	8.6	2110N12	53	24.1
2015	17	7.7	4025	20	9.1	2160N12	55	25
2025	17	7.7	4035	20	9.1	2220N12	56	25.5
2035	17	7.7	4055	23	10.5	2270N12	101	45.9
2055	19	8.6	4080	24	10.9	4160N12	57	25.9
2080	31	14.1	4110	32	14.5	4220N12	58	26.4
2110	51	23.2	4160	55	25	4270N12	60	27.3
2160	53	24.1	4220	56	25.5	4330N12	106	48.2
2220	54	24.5	4270	58	26.4	4400N12	109	49.5
2270	98	44.5	4330	103	46.8	4500N12	113	51.4
2330	178	80.9	4400	106	48.2	2010N4	16	7.3
6060	20	9	4500	110	50	2015N4	18	8.2
6120	61	28	4600	210	95.5	2025N4	18	8.2
6160	65	30	4750	215	97.7	2035N4	18	8.2
6220	67	31	410K	305	138.6	2055N4	31	14
6270	110	50	412K	315	143.2	2080N4	31	14
6330	110	50	415K	336	152.7	4015N4	20	9
6400	111	51	420K	359	163.2	4025N4	21	9.5
6500	190	86	425K	491	223.2	4035N4	21	9.5
6600	196	89	430K	681	309.5	4055N4	24	10.9
6750	200	91	435K	697	316.8	4080N4	32	14.5
610K	302	137				4110N4	32	14.5
612K	304	138						
615K	310	141						
620K	440	200						
625K	448	204						

# TOSHIBA

## G3 Options

A number of option accessories are available for the G3 series of inverters and can be purchased from your authorized Toshiba distributor or representative. If you need assistance finding a source for Toshiba products in your area, consult Toshiba at 1-800-231-1412.

Product	TOSHIBA P/N
NEMA 12 chassis G3	VT130G3U ____ N12
NEMA 4 chassis G3	VT130G3U ____ N4
Chassis fan/filter kits	VT130G3-T12CON8 (60-75 HP) VT130G3-T12CON9 (100-200 HP)
G3 extender box (breaker, NEMA 1 enclosure)	FXG3- ____
G3 extender box (breaker, bypass, NEMA 1 enclosure)	EXG3- ____
G3 build-up (custom controls and enclosures)	ESPG3- ____
RS232 programming software (free)	consult distributor
120 VAC digital input option	G3-INP
120 VAC digital input option (extended capability)	G3-ACI
RS485 Communication Board (38.4 Kbaud) (19.2 Kbaud)	INV3-COM-C INV3-COM-A
Extended Terminal Option Board (Offers speed feedback control, 3 additional programmable inputs, 1 additional programmable Form C relay, pulse input capability)	INV3-COM-D
RS485 Extended Terminal Option Board (Offers same capabilities as INV3-COM-D plus 19.2 K baud RS485 communication)	INV3-COM-B
<i>Modbus+</i> * network communication board	INV3-MODPLUS
<i>Remote I/O</i> * network communication board	INV3-RIO
<i>DeviceNet</i> * network communication board	INV3-DEVICENET
BCD/12-bit binary input option board	G3-VFSX-4526A
<i>Toshiba F-10</i> network communication board	G3-VF5X-1254A
<i>Toshiba S-20</i> network communication board	G3-VF5X-1255A
Input fuse adapter kit (required to internally mount input fuses in G3U2110-2220 and G3U4160-4270 drives). Fuses not included.	INV3-FUSE-KIT
Isolated 4-20 mA input/output board	consult distributor
Long Lead Filters	GCIMLL ____
RF/EMI Filters	3H ____ DF

\* Modbus+ is a trademark of Modicon Inc. Remote I/O is a trademark of Allen Bradley Co. Inc. Device Net is a trademark of Open DeviceNet Vendor Association Inc.



# TOSHIBA

## G3 Options (con't)

Product	TOSHIBA P/N
Option ROM: Traverse Control (for 230/460 volt drives)	INV3-ROM-6200
Keypad extender cables	3 foot length 9 foot length 15 foot length
Kit to secure extender cable to keypad	SX-CABLE-1M SX-CABLE-3M SX-CABLE-5M
Kit to secure extender cable to G3	INV3-MKIT INV3-BKPANEL
Dynamic Braking Resitors	PBR- _____ - ___
Input Fuses	Contact Toshiba distributor
DC Link Reactor	INV3-DCL- _____
Remote Stations (custom stop/start, metering, etc.)	VT-REMOTE- _____

### Additional G3 documentation available

RS232 Inverter/PC Communications Software Manual (for the free software)

Industrial Application Manual (contains information on the G3's application macros)

RS232C Communications Manual (protocol information)

Application Guidelines  
(programming examples such as dancer control, three-wire start, pattern run, and PID)

Devicenet Communications Option Manual

RS485 Communications Manual (protocol information)

Extended Terminal Block Option Manual

Traverse Option ROM Instruction Manual

Modbus+ Communications Option Manual

### Cutout Dimensions for Keypad and Cable Securing Kit (INV3-MKIT)

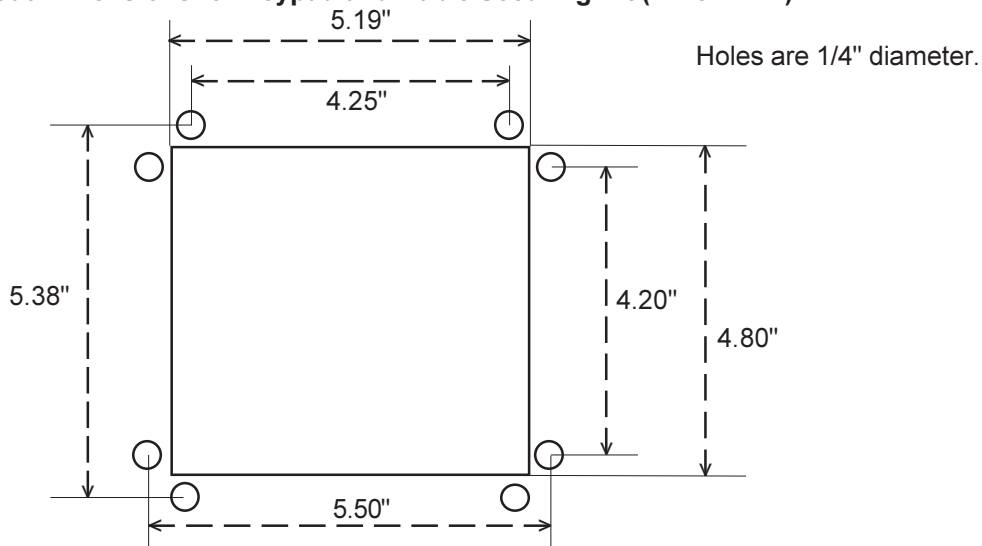

**INDEX****A**

Acc/dec #1/#2 switch frequency .....	8-2, 9-5
Acc/Dec complete detection bandwidth .....	8-6, 9-13
Acc/dec pattern #1 selection .....	8-1, 9-4
Acc/dec pattern #2 selection .....	8-2, 9-5
Acc/dec pattern adjust high .....	8-1, 9-5
Acc/dec pattern adjust low .....	8-1, 9-5
Acc/dec selection .....	8-2, 9-6
Acc/dec time units selection .....	8-30, 9-27
Acceleration time .....	9-4
Acceleration time #1 .....	8-1, 9-3
Acceleration time #2 .....	8-2, 9-5
Adjustment range (parameters) .....	8-1 thru 8-32
After sales service .....	10-1
Alarm setting for cumulative run timer .....	8-15, 9-19
AM terminal function selection .....	8-27, 9-25
AM/FM terminal adjustment parameters .....	8-27
Ammeter adjustment .....	8-27, 9-25
Ampacity .....	3-1 to 3-3
Analog input filter .....	8-8, 9-14
Analog meter adjustment .....	9-25
Auto-restart .....	8-14, 9-17
Auto-tuning enable .....	8-32, 9-29

**B**

Bandwidth Acc/Dec detection .....	8-6
Bandwidth of jump frequency #1 thru #3 .....	8-4
Base frequency #1 .....	8-1
Base frequency #2 .....	8-2
Base frequency voltage select .....	8-1
Basic operation .....	7-1 thru 7-4
Baud rates .....	8-24
Bearing considerations .....	4-7
Bias/Gain adjustments .....	9-14
Binary input selection .....	8-9
Binary reference point frequency .....	8-9
Binary reference pt. setting .....	8-9
Blind function selection .....	8-31, 9-2
Blind/unblind function parameters .....	8-31, 9-2
Braking resistor selection .....	8-13, 9-16
Braking selection (dynamic) .....	8-13, 9-15

**C**

Capacitors (PF) precautions .....	2-2
Capacity of motor rating .....	8-32
Carrier frequency .....	8-4
Catch spinning motor .....	9-17
CEC requirements .....	4-6
Circuit board (control) .....	5-3
Circuit board (main) .....	5-1
Circuit board (terminal) .....	5-2
Circuit breaker size (MCCB) .....	4-3

**INDEX (cont'd)****C (con't)**

Clearances .....	2-1
Coast stop .....	7-2
Codes (regulatory) .....	2-1
Color (cabinet) .....	3-5
Command mode selection .....	8-28, 9-25
Commercial power switching output .....	8-6
Communication selection .....	8-24
Communication setting parameters .....	8-24 thru 8-25
Confirmation (wiring) .....	2-3
Connection diagrams .....	4-1 to 4-3
Continue mode for speeds #1 thru #15 .....	8-19 thru 8-21
Control system .....	3-4
Conveyor application parameters .....	8-26
Cooling fan control .....	8-15
Cooling method .....	3-4
CPU version .....	8-30
Cumulative run timer alarm setting .....	8-15
Current level of stall protection .....	8-14
Current units selection .....	8-30
Cutout, keypad .....	11-7

**D**

Dancer .....	11-7
Data bits (number) .....	8-24
DC injection braking start frequency .....	8-13
DC injection current .....	8-13
DC injection time .....	8-13
Deceleration time #1 .....	8-1
Deceleration time #2 .....	8-2
Delay time FL output .....	8-6
Delay time LOW output .....	8-6
Delay time OUT output .....	8-6
Delay time RCH output .....	8-5
Detection bandwidth Acc/Dec .....	8-6
Detection level for low current .....	8-14
Detection time for low current .....	8-14
Detection time for undervoltage .....	8-14
Differential gain .....	8-22
Dimensions .....	11-1
Dimensions, keypad cutout .....	11-7
DIP switch SW1 .....	5-3
Direction selection .....	8-3
Display .....	6-1
Disposal .....	1-1
Drive time for speeds #1 thru #15 .....	8-19 to 8-21
Drooping control and amount .....	8-22
Dynamic braking .....	8-13

**E**

EEPROM version .....	8-30
Electronic thermal protection level #2 .....	8-2
EMC (European electro-magnetic compatibility) .....	2-5
Emergency off .....	8-13, 7-2

**INDEX (cont'd)****E (cont'd)**

Emergency stop selection .....	8-13
Enclosure .....	11-1
End frequency .....	8-4
Error messages .....	10-3
Examples, connection .....	4-8
Examples,programming .....	9-30
Exceeding motor peak voltage .....	4-7
Excitation current .....	9-31

**F**

F terminal function .....	8-5, 5-2
Factory settings (parameters) .....	8-1 to 8-32
Failsafe inputs .....	9-9
Fan application parameters .....	8-26
Fan control selection .....	8-15
Fault clearing .....	10-3
Fault explanations .....	10-3
Fault trip saving enable .....	8-15
Feedback control selection .....	8-22
Feedback input signal selection .....	8-22
Feedback parameters .....	8-22 thru 8-23
Filter chart (EMC) .....	2-5
FM terminal function selection .....	8-27
Forward/reverse switching .....	7-1, 7-2, 8-3
FP output terminal .....	8-7, 5-2
Frequency accuracy .....	3-4
Frequency command value setting .....	7-1
Frequency display resolution .....	8-30
Frequency meter adjustment .....	8-27
Frequency mode selection .....	8-28
Frequency priority selection .....	8-8
Frequency rating of motor .....	8-32
Frequency setting mode selection .....	8-28
Frequency setting parameters .....	8-8 to 8-12
Frequency setting resolution .....	3-4
Frequency units scale factor .....	8-30
Function selection FL output .....	8-6
Function selection LOW output .....	8-6
Function selection OUT output .....	8-6
Function selection RCH output .....	8-5
Functions (key) .....	6-2
Fundamental parameter selection .....	8-3
Fundamental parameters #1 .....	8-1
Fundamental parameters #2 .....	8-2
Fwd/Rev DC injection priority control .....	8-13

**G**

Groups .....	9-1
Grounding .....	4-7

**H**

Hoist application parameters .....	8-26
Hold time FL output .....	8-6, 5-2
Hold time LOW output .....	8-6, 5-2
Hold time OUT output .....	8-6

**INDEX (cont'd)**

**H (cont'd)**

Hold time RCH output .....	8-5, 5-2
Humidity (relative) .....	3-5
Hysteresis of run frequency .....	8-4

**I**

Incoming power switching frequency .....	8-6
Industrial application parameters .....	8-26
Industrial parameters selection .....	8-28
Injection braking .....	8-13
Input filter .....	8-8
Input selection for binary input .....	8-9
Input selection for terminal IV .....	8-9, 5-2
Input selection for PG input .....	8-9
Input selection for terminal RR .....	8-8, 5-2
Input selection for terminal RX .....	8-8, 5-2
Input impedance .....	3-4
Input signals .....	3-4
Input terminal selection .....	8-5
Inspection of new unit .....	1-1
Installation precautions .....	2-1 to 2-2
Integral gain .....	8-22
Inverter number .....	8-24
Inverter trip codes .....	10-3
Inverter typeform .....	8-30
Isolation .....	2-3
IV input selection .....	8-8, 5-2
IV reference point frequency .....	8-8
IV reference point setting .....	8-8

**J**

Jog run frequency .....	8-9
Jog run mode .....	7-1
Jog stop control .....	8-9
Jump frequency enable .....	8-4
Jumpers JP3, JP4 .....	5-2

**K**

Key functions .....	6-2
Keys .....	6-1,6-2

**L**

Lag time constant .....	8-22
Language selection .....	7-2
LED charge indicator .....	5-2
LED local/remote indicator .....	6-1
Level for overtorque trip .....	8-15
Load moment of inertia .....	8-32
Lockout cancellation .....	9-26
Low current detection level .....	8-14
Low current detection selection .....	8-14
Low current detection time .....	8-14
Low speed signal output frequency .....	8-6
Lower limit frequency .....	8-1
Lower limit frequency (PID) .....	8-22
Lug capacity .....	4-4

**INDEX (cont'd)****M**

Machine tools application parameters .....	8-26
Magnetic contactors (output) .....	2-2
Maintenance .....	2-4
Master/slave selection .....	8-24
Maximum output frequency .....	8-1
Maximum output voltage #1 .....	8-1
Maximum output voltage #2 .....	8-2
MCCB precautions .....	4-6
Meter adjustment .....	9-23
Mode activation of preset speeds .....	8-10
Mode of operating speeds 1 to 15 .....	8-10 to 8-12
Monitor messages .....	7-3
MOP .....	9-9,9-30
Motor OL time limit .....	8-14
Motor parameters .....	8-32
Motor poles .....	8-32
Motor rated capacity .....	8-32
Motor rated frequency .....	8-32
Motor rated RPM .....	8-32
Motor rated voltage .....	8-32
Motor selection application .....	4-7
Motor shaft stationary control .....	8-13
Motor speed search .....	8-14
Motor type .....	8-32

**N**

NEC requirements .....	4-6
NEMA enclosures .....	3-1 to 3-3, 11-1 to 11-3
Number of data bits .....	8-24
Number of inverter (identifier) .....	8-24
Number of motor poles .....	8-32
Number of preset speeds .....	8-10

**O**

OL reduction start frequency .....	8-14
OL time limit .....	8-14
Operating mode preset speeds 1 thru 15 .....	8-10 thru 8-12
Operating panel .....	6-1, 6-2
Options .....	11-6
Output fault detection .....	8-14
Output frequency .....	3-4
Output short-circuit detection .....	8-14
Output signals .....	3-5
Output contact functions .....	9-11
Output voltage regulation .....	3-4
Overload protection .....	4-6
Overload selection .....	8-14
Override change multiplier .....	8-23
Override control selection .....	8-23
Override multiplier selection .....	8-23
Overtorque trip selection .....	8-15
Overvoltage stall protection .....	8-13

**INDEX (cont'd)****P**

Panel control parameters.....	8-3
Panel feedback control .....	8-3
Panel keys .....	6-2
Panel layout .....	6-1
Panel lockout cancellation .....	9-26
Panel operation mode selection .....	8-28
Panel reset selection .....	8-3
Parallel conductors .....	4-6
Parameter explanations .....	9-1 to 9-29
Parameters adjustment range .....	8-1 to 8-32
Parameters changed from factory default .....	9-2
Parameters factory settings .....	8-1 to 8-32
Parity .....	8-24
Pass number .....	8-30
Pattern groups number of cycles .....	8-16 thru 8-18
Pattern groups preset speed selections .....	8-16 thru 8-18
Pattern run continue mode .....	8-16
Pattern run control parameters .....	8-16 to 8-21
Pattern run selection .....	8-16
PG input (number of pulses and phases) .....	8-22
PG input selection .....	8-9
PG reference point frequency .....	8-9
PG reference point setting .....	8-9
PID deviation of upper and lower limit.....	8-22
PID deviations limit activation .....	8-22
Potential terminal function .....	8-5
Power factor improvement precautions .....	2-2
Power/inverter switching frequency .....	8-6
Power/inverter switching output .....	8-6
Precautions .....	2-1, 2-2
Preset frequency for speeds 1 thru 15.....	8-10 to 8-12
Preset speed mode activation .....	8-10
Preset speed selection .....	8-10
Preset speeds operating mode 1 thru 15 .....	8-10 to 8-12
Program mode .....	8-1
Proportional gain .....	8-22
Protection parameters .....	8-13 to 8-15
Protective functions .....	3-2
Pulse frequency selection .....	8-7
Pump application parameters .....	8-26
PWM carrier frequency .....	8-4

**Q**

Qualified person .....	iii
------------------------	-----

**R**

R terminal finction .....	8-5, 5-2
Rated frequency of motor .....	8-32
Rated RPM of motor .....	8-32
Rated voltage of motor .....	8-32

**INDEX (cont'd)****R (cont'd)**

Regeneration power ride-through .....	8-14
Regulatory codes .....	2-1, 4-6
Requesting service .....	10-1
RES terminal function .....	8-5
Resetting factory parameters .....	8-28
Resistor value for dynamic braking .....	9-16
Response time selection input .....	8-5
Retry .....	10-3
Retry selection (number of attempts) .....	8-13
Retry time selection .....	8-13
Retryable faults .....	9-12
Reverse operation disable select .....	8-1
Reverse run .....	7-1,7-2,5-2,8-3
Ride-through control .....	8-14
ROM version .....	8-30
RPM rating of motor .....	8-32
RR input selection .....	8-8
RR input terminal .....	8-7,5-2
RR reference point frequency .....	8-8
RR reference point setting .....	8-8
RS232 baud rate .....	8-24
RS485 baud rate .....	8-24
RS485/12-bit binary bias, gain activation .....	8-25
RS485/12-bit binary frequency setting .....	8-25
RS485/12-bit binary point setting .....	8-25
Run frequency .....	8-4
Run frequency for jog .....	8-9
Run/stop commands .....	9-25
RX input selection .....	8-8
RX reference point frequency .....	8-8
RX reference point setting .....	8-8

**S**

S1 terminal .....	8-5
S2 terminal .....	8-5
S3 terminal .....	8-5
S4 terminal .....	8-5
S5 terminal .....	8-5
S6 terminal .....	8-5
S7 terminal .....	8-5
Scale factor .....	8-30
Searching .....	9-2
Secondary magnetic contactors (MC) .....	2-2
Service after sales .....	10-1
Service environment .....	3-5
Service life .....	10-2
Shipping weights .....	11-5
Short-circuit detection on output .....	8-14
Signal isolation .....	2-2
Special control parameters .....	8-4
Special RR input function selection .....	8-7, 5-2
Speed #1 thru #15 drive continue mode .....	8-19 to 8-21
Speed #1 thru #15 drive time .....	8-19 to 8-21



**INDEX (cont'd)****S (con't)**

Speed reach frequency .....	8-6
Speeds 1 thru 15 preset frequency .....	8-10 to 8-12
ST terminal function .....	8-5
Stall protection .....	8-13
Stall protection current level .....	8-14
Stall protection enable .....	8-14
Stall protection level #2 .....	8-2
Stall protection selection #2 .....	8-2
Standard setting mode selection .....	8-28
Standard specifications .....	3-4 to 3-5
Start-up .....	2-4
Start-up frequency .....	8-4
Start-up frequency OL reduction .....	8-14
Stationary control .....	8-13
Stop control for jog .....	8-9
Stop pattern selection .....	8-3
Storage .....	1-1
Switch SW1 (DIP) .....	5-3
Switching forward/reverse during run .....	7-1

**T**

Temperature (ambient) .....	3-5
Terminal strip (control) .....	5-2
Terminal functions .....	5-3 to 5-5
Terminal identification .....	5-3 to 5-5
Terminal location .....	5-3 to 5-5
Terminal selection parameters .....	8-5 to 8-7
Textiles application parameters .....	8-26
Thermal protection .....	8-14
Three wire control .....	9-9
Time of ride-through .....	8-14
Time units selection for Acc/dec .....	8-30
Torque current .....	9-27,9-31
Tosline F10/S20 command input .....	8-24
Tosline F10/S20 communication error mode .....	8-25
Tosline F10/S20 monitor output .....	8-25
Transistor type .....	3-4
Trim .....	9-22
Trip clear command .....	10-3
Trip codes .....	10-3
Trip saving on fault enable .....	8-15
Trip selection for undervoltage .....	8-14
Troubleshooting .....	10-3
True Torque Control .....	9-31
Type of motor .....	8-32
Typeform .....	8-30

**U**

Unblind/blind function parameters .....	8-31
Unblinding .....	9-2
Undercurrent .....	8-14
Undervoltage detection time .....	8-14
Undervoltage trip selection .....	8-14
Unlock combination .....	8-30

INDEX (cont'd)

**U**

Unusual service conditions ..... 4-5  
Upper limit frequency ..... 8-1  
Utility parameters ..... 8-28 to 8-31

**V**

Vibration ..... 3-3  
Voltage boost #1 ..... 8-1  
Voltage boost #2 ..... 8-2  
Voltage rating of motor ..... 8-32  
Voltage units selection ..... 8-30  
Volts/Hertz pattern ..... 8-1

**W**

Weights (shipping) ..... 11-5  
Wire size for control and signal circuit ..... 4-4  
Wire size for grounding ..... 4-7  
Wire size for main and motor power ..... 4-4  
Wiring confirmation ..... 2-3

# **TOSHIBA**

**TOSHIBA INTERNATIONAL CORPORATION**

INDUSTRIAL DIVISION

13131 West Little York Rd., Houston Texas 77041

Tel: [800] 231-1412 Fax: [713] 466-8773 Telex: 762078

World Wide Web <http://www.tic.toshiba.com>