

INDEX	MDSL0031-04
REV. LEVEL	4
SHEET	1 OF 1

TOSHIBA/HOUSTON
EQP III "XS" & "841"

TOTALLY-ENCLOSED FAN-COOLED
HORIZONTAL FOOT-MOUNTED
PREMIUM EFFICIENCY SEVERE DUTY

Fr. 254T-256T

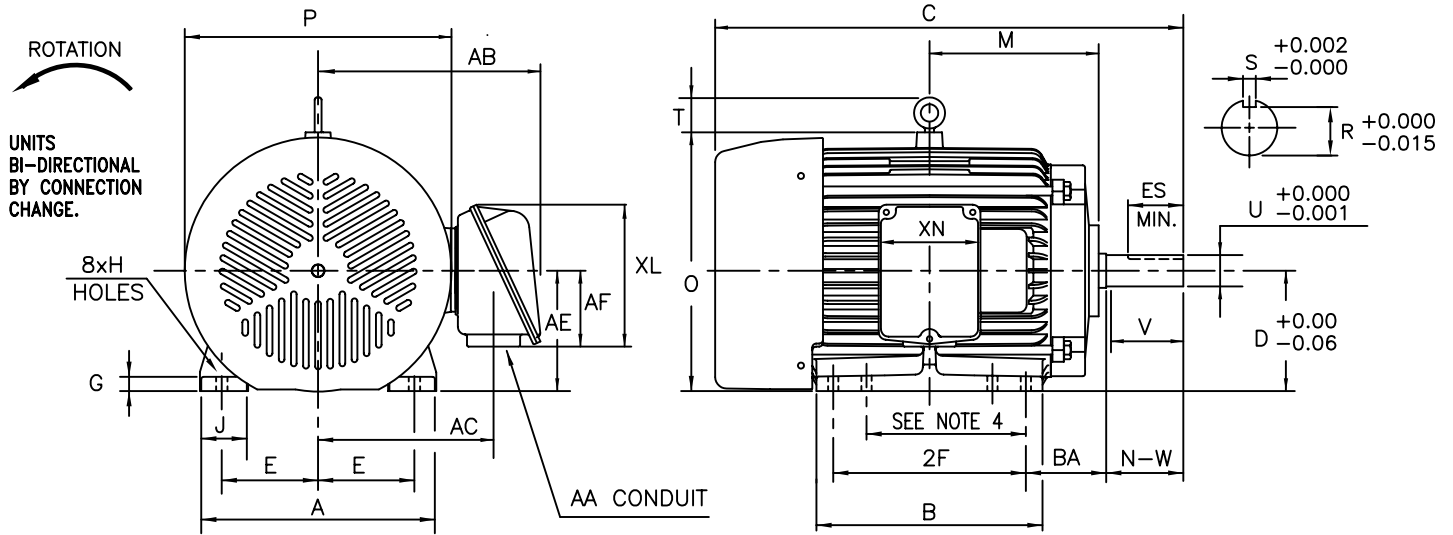

UNITS: INCHES

FRAME SIZE	MOUNTING				CONDUIT BOX						
	E	2F	H	BA	AA	AB	AC	AE	AF	XL	XN
254T	5.00	8.25	0.53	4.25	1.25	12.2	9.1	6.3	3.9	7.4	5.3
256T	5.00	10.00	0.53	4.25	1.25	12.2	9.1	6.3	3.9	7.4	5.3

FRAME SIZE	MOTOR DIMENSIONS									
	A	B	C	D	G	J	M	O	P	T
254T/256T	12.3	11.7	24.4	6.25	0.75	2.4	8.8	13.4	13.9	1.8

FRAME SIZE	SHAFT EXTENSION			KEY SEAT			BEARINGS		MAXIMUM WEIGHT
	N-W	V	U	R	S	ES	LS	OS	
254T/256T	4.00	3.75	1.625	1.416	0.375	2.91	6309C3	6308C3	342 lbs.

NOTES:

- DIMENSION V REPRESENTS LENGTH OF STRAIGHT PART OF SHAFT.
- CONDUIT BOX MAY BE ROTATED IN 90° INCREMENTS AND MAY BE MOUNTED ON OPPOSITE SIDE ON SPECIAL ORDER.
- KEY DIMENSIONS EQUAL S x S x 2.88 (MOTOR SUPPLIED WITH KEY)
- DIMENSIONS FOR 254T MOUNTING EQUAL (2F) LOCATED IN 254T SIDE VIEW.
- MOTOR WEIGHT SHOWN IS MAXIMUM HORSEPOWER IN FRAME.

ALL DATA SUBJECT TO CHANGE WITHOUT NOTICE.
FOR CONSTRUCTION USE ONLY CERTIFIED DATA.

CERTIFIED DATA

CUSTOMER: _____ P.O. NO.: _____ TAG NO.: _____

MOTOR MODEL NO.: _____ TOSHIBA FILE NO.: _____

HP: _____ RPM (SYN.): _____ VOLTAGE: _____ Hz: _____

FRAME SIZE: _____ LOG NO.: _____ LOG REV. LEVEL: _____

REMARKS: _____

PER: _____ ISSUE DATE: _____ SUPERSEDES: _____